

Application

Used to convert a direct-current input signal into a pneumatic output signal for measuring and control tasks · Particularly suitable as intermediate element between electric measuring devices and pneumatic controllers or between electric control devices and pneumatic control valves



The Type 6116 i/p Converter proportionally converts the electric input signal into a pneumatic output signal.

The signal converter accepts a load-independent 4 to 20 mA direct-current input signal. Depending on the supply air pressure, the converter supplies a pneumatic output signal of 0.2 to 1 bar (3 to 15 psi), 0.4 to 2 bar (6 to 30 psi) or pressure ranges up to 8 bar (120 psi). Depending on the signal range, the Type 6116 is equipped with Type 6109 or Type 6112 i/p Converter module (see Table 1).

Special features

- Continuous, linear characteristic
- High accuracy and excellent dynamic response
- Extremely low air consumption
- Operation without supply pressure regulator possible (see Table 1)
- Switch-off electronics guarantee venting at zero point

Versions

For **safe areas**: Type 6116-0...

For **hazardous areas**:

Type 6116-1... Ex i according to ATEX and GOST

Type 6116-2... Ex d according to ATEX, IEC and GOST

Type 6116-3... Explosion-proof acc. to CSA and FM standards

Type 6116-4... Intrinsically safe according to CSA and FM standards

Type 6116-5... Explosion-proof/Australia/IEC/Korea

Type 6116-6... Intrinsically safe/Australia/IEC

Type 6116-7... Ex d according to JIS standard/Japan

Further versions

- **Type 6116-x2xxxxxxxxx2xxx**: temperatures down to $-45\text{ }^{\circ}\text{C}$
- **Type 6116-0...**
- AS-interface connection with Type 6150 Slave
- Voltage input (e.g. 0 to 10 V) with Type 6151 u/i Module

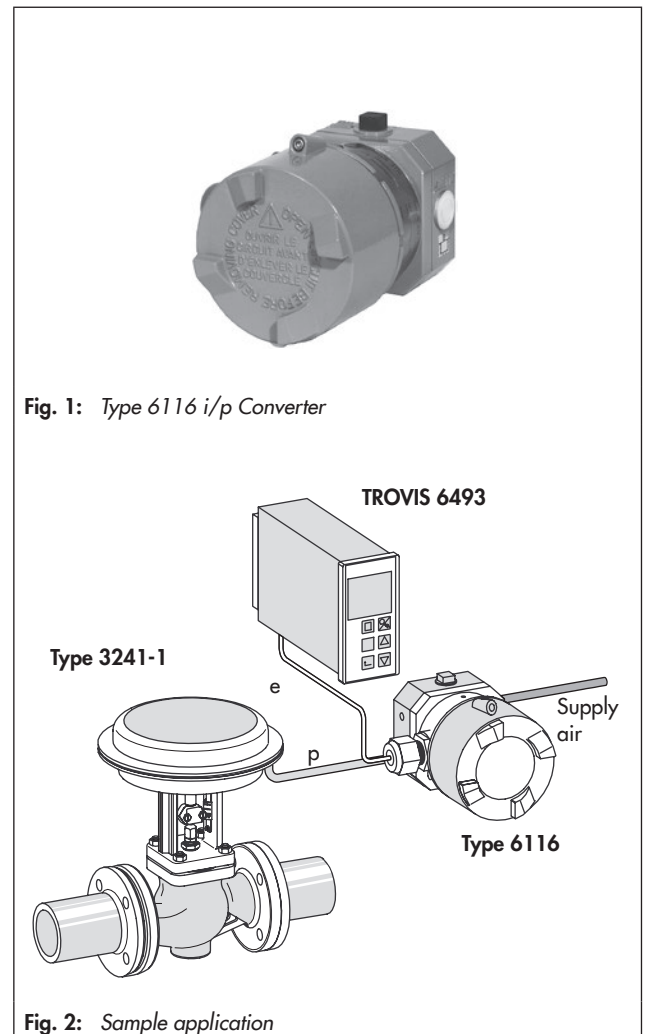

Fig. 1: Type 6116 i/p Converter

Fig. 2: Sample application

- **Electropneumatic converter without booster or switch-off electronics**
Converters can be combined with SAMSON Type 3760, Type 3766-000 (model index .02 and higher) and Type 4765 Pneumatic Positioners.
- **Type 6116-xx060111000xxxx** for attachment to p/p positioners (1/2 NPT connection)
- **Type 6116-xx060112000xxxx** for attachment to p/p positioners (M20 x 1.5 connection)

Principle of operation (see Fig. 3)

The electropneumatic converter consists of an i/p converter module, which operates according to the force-balance principle, and a downstream volume booster.

When operated, the supplied direct current (4) flows through the plunger coil (2) located in the field of a permanent magnet (3). At the balance beam (1), the force of the plunger coil, which is in proportion to the current, is balanced against the force of the dynamic backpressure. The backpressure is produced on the flapper plate (6) by the air jet leaving the nozzle (7).

The nozzle is supplied with air from the pneumatic output (36). With an input signal of 0 mA, an output pressure of approximately 100 mbar is already issued due to the offset spring.

The air supply (8) flows into the lower chamber and a certain amount of air flows to the output. As the current increases, the flapper moves closer to the nozzle. The force of the dynamic backpressure pushes both the diaphragm (10) and the sleeve (9) downward, allowing additional air to enter the bottom chamber. The passing air volume increases until the forces acting on the diaphragm reach a state of equilibrium. When the current decreases, this action is reversed. The dynamic backpressure produced by the nozzle and flapper decreases and the diaphragm is pressed upward. In this process, it releases the sleeve (9) and opens the vent (EXHAUST) until the forces on the diaphragm are equal again.

Switch-off electronics (see Fig. 4)

Converter modules with an input signal range from 4 to 20 mA have a slide switch which activates the switch-off electronics. The electronics cause the pneumatic output to be vented up to approx. 100 mbar when the input signal falls below 4.08 mA tolerance. In this way, the tight shut-off function of a valve can be guaranteed.

Combined with a Type 3760, Type 3766-000 or Type 4765 Pneumatic Positioner

The Type 6116-xx06011x000xxxx i/p Converter without booster or switch-off electronics can be combined with the above listed positioners to form a version in a flameproof enclosure (Ex d). With Type 3760 and Type 4765 Positioners, the i/p converter is attached to the control valve according to NAMUR and hooked up to the positioner (see Fig. 5).

The Type 3766-000 Positioner can be connected directly to the i/p converter. The positioner type must be specified when ordering any accessories.

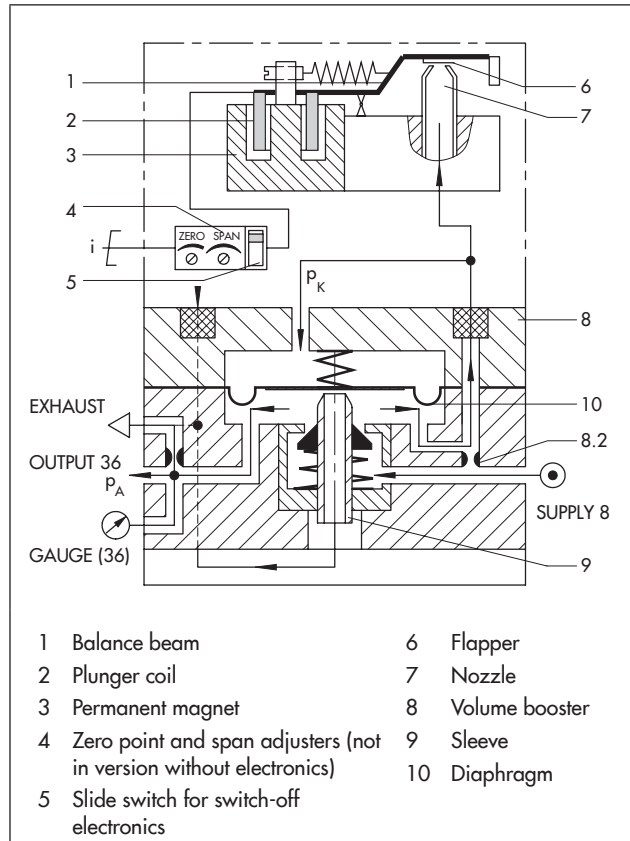

Fig. 3: Functional drawing of Type 6116

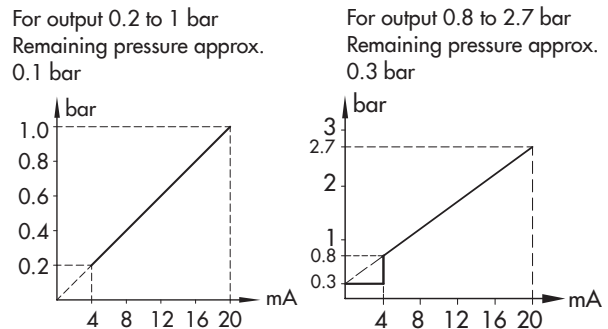

Fig. 4: Switch-off electronics

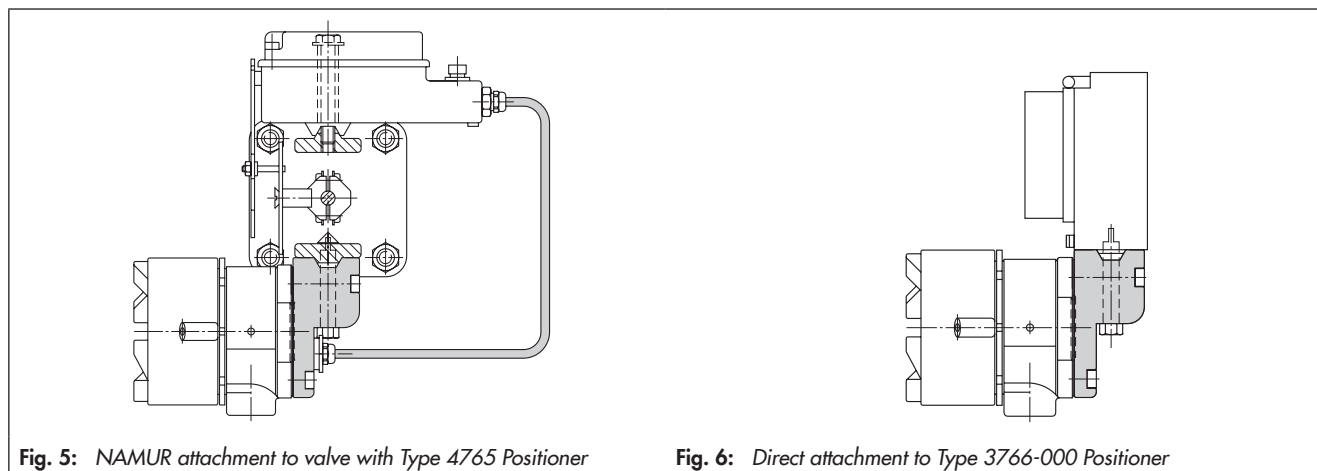



Fig. 5: NAMUR attachment to valve with Type 4765 Positioner

Fig. 6: Direct attachment to Type 3766-000 Positioner

Table 1: Technical data

Type	No explosion protection	6116-0																																
	With explosion protection	Types 6116-1/-2/-3/-4/-5/-6/-7, see Table 2																																
Input ⁵⁾	4 to 20 mA; other signals on request Minimum current > 3.6 mA; load ≤ 6 V (corresponds to 300 Ω at 20 mA) For explosion-protected versions: load 7 V (corresponds to 350 Ω at 20 mA) Converters without switch-off electronics R _i = 200 Ω ± 7.5 %																																	
Output ⁵⁾	0.2 to 1 bar (3 to 15 psi) (Type 6109 i/p Converter module) 0.4 to 2 bar (6 to 30 psi) (Type 6112 i/p Converter module) Special ranges adjusted according to customer specification at the factory: Output range = Initial value¹⁰⁾ + Span Δp with Type 6112 i/p Converter module)																																	
			<table border="0"> <tr> <td>0.1 to 0.4 bar</td> <td>+</td> <td>0.75 to 1.0 bar</td> <td>Module A</td> </tr> <tr> <td>0.1 to 0.4 bar</td> <td>+</td> <td>1.0 to 1.35 bar</td> <td>Module B</td> </tr> <tr> <td>0.1 to 0.4 bar</td> <td>+</td> <td>1.35 to 1.81 bar</td> <td>Module C</td> </tr> <tr> <td>0.1 to 0.8 bar</td> <td>+</td> <td>1.81 to 2.44 bar</td> <td>Module D</td> </tr> <tr> <td>0.1 to 0.8 bar</td> <td>+</td> <td>2.44 to 3.28 bar</td> <td>Module E</td> </tr> <tr> <td>0.1 to 0.8 bar</td> <td>+</td> <td>3.28 to 4.42 bar</td> <td>Module F</td> </tr> <tr> <td>0.1 to 1.2 bar</td> <td>+</td> <td>4.42 to 5.94 bar</td> <td>Module G</td> </tr> <tr> <td>0.1 to 1.2 bar</td> <td>+</td> <td>5.94 to 8.0 bar</td> <td>Module H⁹⁾</td> </tr> </table>	0.1 to 0.4 bar	+	0.75 to 1.0 bar	Module A	0.1 to 0.4 bar	+	1.0 to 1.35 bar	Module B	0.1 to 0.4 bar	+	1.35 to 1.81 bar	Module C	0.1 to 0.8 bar	+	1.81 to 2.44 bar	Module D	0.1 to 0.8 bar	+	2.44 to 3.28 bar	Module E	0.1 to 0.8 bar	+	3.28 to 4.42 bar	Module F	0.1 to 1.2 bar	+	4.42 to 5.94 bar	Module G	0.1 to 1.2 bar	+	5.94 to 8.0 bar
0.1 to 0.4 bar	+	0.75 to 1.0 bar	Module A																															
0.1 to 0.4 bar	+	1.0 to 1.35 bar	Module B																															
0.1 to 0.4 bar	+	1.35 to 1.81 bar	Module C																															
0.1 to 0.8 bar	+	1.81 to 2.44 bar	Module D																															
0.1 to 0.8 bar	+	2.44 to 3.28 bar	Module E																															
0.1 to 0.8 bar	+	3.28 to 4.42 bar	Module F																															
0.1 to 1.2 bar	+	4.42 to 5.94 bar	Module G																															
0.1 to 1.2 bar	+	5.94 to 8.0 bar	Module H ⁹⁾																															
	Max. air output capacity ³⁾	2.0 m ³ /h at an output of 0.6 bar (0.2 to 1.0 bar) · 2.5 m ³ /h at an output of 1.2 bar (0.4 to 2.0 bar) · 8.5 m ³ /h at an output of 5.0 bar (0.1 to 8.0 bar)																																
Supply air		Minimum 0.4 bar above the upper signal pressure range value, max. 10 bar without supply pressure regulator max. 6 bar with devices in Ex d version																																
	Air quality acc. to ISO 8573-1: 2001	Max. particle size and density: Class 4 · Oil content: Class 3 · Pressure dew point: Class 3 or at least 10 K below the lowest ambient temperature to be expected																																
	Air consumption ²⁾	0.08 m ³ /h at 1.4 bar · 0.1 m ³ /h at 2.4 bar · Max. 0.26 m ³ /h at 10 bar																																
Characteristic	Characteristic: Output linear to input																																	
	Hysteresis	≤ 0.3 % of upper range value																																
	Deviation from terminal-based conformity	≤ 1 % of upper range value (for upper range values up to 5 bar); more exact values on request ≤ 1.5 % of upper range value (for upper range values above 5 bar)																																
Effect in % of the upper range value	Supply air: 0.1 %/0.1 bar ²⁾																																	
	Alternating load, supply air failure, interruption of the input current: < 0.3 %																																	
	Ambient temperature: lower range value < 0.03 %/K, span < 0.03 %/K																																	
Dynamic response																																		
	Limiting frequency	5.3 Hz																																
	Phase shift	-130°																																
Variable position	Max. 3.5 % depending on attachment: ±1 % when horizontal (Type 6109) Max. 1 % depending on attachment: ±0.3 % when horizontal (Type 6112)																																	
Ambient conditions, degree of protection, compliance and weight																																		
Storage temperature	-45 to 80 °C																																	
Ambient temperature ¹¹⁾	With Type 6109	-30 to 70 °C ⁶⁾ ; -30 to 60 °C ¹⁾																																
	With Type 6112	-40 to 70 °C ⁶⁾ ; -40 to 60 °C ¹⁾ ⁷⁾																																
Degree of protection	IP 54 ⁴⁾ , IP 65 ⁸⁾ , NEMA 4																																	
Compliance																																		
Weight	Approx. 0.85 kg																																	
Explosion protection																																		
ATEX, IECEx, ...	See Table 2																																	
Materials																																		
Housing	Die-cast aluminum, chromated and plastic coated																																	
Cable gland (standard)	Black polyamide (6 to 12 mm clamping range, -20 to 80 °C)																																	

¹⁾ Details (including electric specifications and installation instructions) can be found in the EC type examination certificate

²⁾ Measured with average output pressure

³⁾ Measured with 2 m hose with 4 mm inside diameter

⁴⁾ Observe recommended mounting position

⁵⁾ See Table 3 when combined with a positioner

⁶⁾ Devices without explosion protection

⁷⁾ Special version down to -45 °C, temperature range on request

⁸⁾ Possible by using accessories

⁹⁾ Max. possible output pressure 8 bar

¹⁰⁾ Initial value raised up to 3.0 bar (special version)

¹¹⁾ Metal cable glands and vent plugs are required for temperatures below -20 °C.

Table 2: Summary of explosion protection certificates for Type 6116 i/p Converter

Version	Type of approval	Certificate number	Date	Type of protection	Comments
6116-1	EC Type Examination Certificate First Addendum	PTB 02 ATEX 2199	2003-03-07	Ex II 2 G Ex ia IIC T6	-45 °C ambient temperature Manufacturer's declaration available for zone 2 and zone 22
	GOST certificate	RU C-DE ... 00749	2014-03-03		
6116-2	GOST certificate	RU C-DE ... 00749	2015-01-27	1 Ex ia IIC T6/T5/T4 Gb X	Ex-Zone 1; valid until 2020-01-27
	EC Type Examination Certificate First Addendum	PTB 98 ATEX 1024 X	1998-04-30	Ex II 2G Ex d IIC T6	-45 °C ambient temperature Manufacturer's declaration available for zone 22
	EC type examination certificate	BVS 14 ATEX E 104 X	2002-01-08		
	IECEx certificate	BVS 14 ATEX E 104 X	2014-06-27	Ex II 2G Ex d IIC T* Gb	Ambient temperature -45 °C < T < 50 °C T6 -45 °C < T < 65 °C T5 -45 °C < T < 80 °C T4 Manufacturer's declaration available for zone 22
	IECEx certificate	IECEx BVS 14.0066X	2014-07-01	Ex d IIC T* Gb	Ambient temperature -45 < T < 50 °C T6 -45 < T < 65 °C T5 -45 < T < 80 °C T4 Hazardous area: zone 1, zone 2 Manufacturer's declaration available for zone 22
	GOST certificate	RU C-DE ... 00749	2015-01-27	1 Ex d IIC T6/T5/T4 Gb X	Valid until 2020-01-27
6116-3	CSA certificate	1471157 (LR 54227-18)	2014-11-14	Cl. I, Gr. B, C, D Cl. II, Gr. E, F, G Cl. III Hazardous area: Division 1	Ambient temperature -45 to 70 °C
	FM certificate	1W5A4.AE	1993-04-01	Cl. I, II, III; Div 1; Gr. B, C, D, E, F, G Cl. I; Div. 2; Gr. B, C, D Cl. II; Div. 2; Gr. F, G Cl. III Type 4X	
6116-4	CSA certificate	1607866 (LR 54227-16)	2005-09-16	Ex ia IIC T6; Cl. I, Zone 0 Cl. I, II; Div 1; Gr. A, B, C, D, E, F, G Cl. I, II; Div. 2; Gr. A, B, C, D, E, F, G Cl. III Type 4 Enclosure	Ambient temperature T6: 60 °C T5: 70 °C T4: 80 °C
	FM certificate	3020228	2005-02-28	Cl. I, Zone 0 AEx ia IIC Cl. I, II, III, Div. 1; Gr. A, B, C, D, E, F, G Cl. I, Div. 2; Gr. A, B, C, D Cl. II, Div. 2; Gr. F, G Cl. III Type 4X	
6116-5	KCS Korea	11-KB4B0-0213	2011-10-24	Ex d IIC T6/T4	Ambient temperature T6: 47 °C; T4: 60 °C
	IECEx certificate	IECEx TSA 05.0015	2005-04-22	Ex d IIC T6/T4	Ambient temperature T6: 47 °C; T4: 60 °C
6116-6	IECEx approval	IECEx TSA 05.0008X	2005-04-04	Ex ia IIC T6 Ex n IIC T6	
6116-7	JIS approval	TC 13622	2014-05-20	Ex d IIC T6	

The test certificates are included in the mounting and operating instructions or are available on request.

Table 3: Technical data (positioner attachment)

Type 6116-xx06011x000xxxx (for positioner attachment)¹⁾

Input	4 to 20 mA, other signals on request, internal resistance approx. 200 Ω at 20 °C
Output	0.2 to 1 bar for positioner

¹⁾ Other data same as in Table 1

Electrical connection

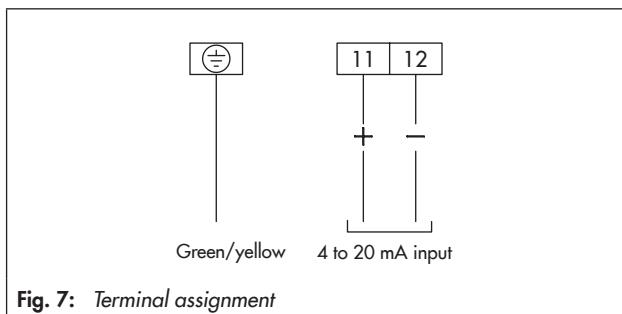

Fig. 7: Terminal assignment

For connection to intrinsically safe circuits, the specifications stated in the certificate of conformity apply as well.

Installation

The converter can be mounted to a wall, pipe or directly to the control valve according to NAMUR.

Ideally, the converter is to be installed horizontally, with the pressure gauge (or screw plug) facing upward. If a different mounting position is used, the zero point must be corrected using the ZERO adjuster.

With degree of protection IP 54, the vent must always be installed facing downward to the floor.

Wall and pipe mounting · Order no. 1400-6216

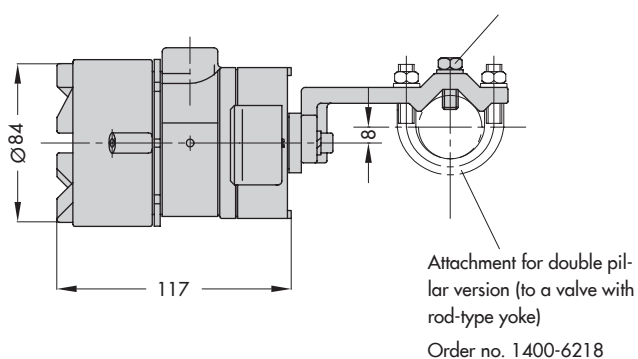
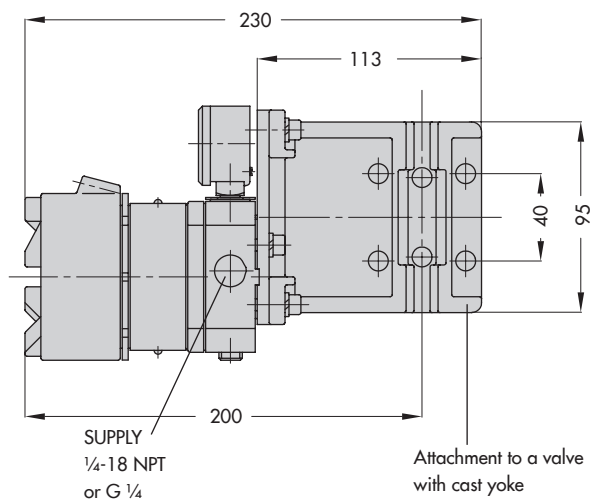
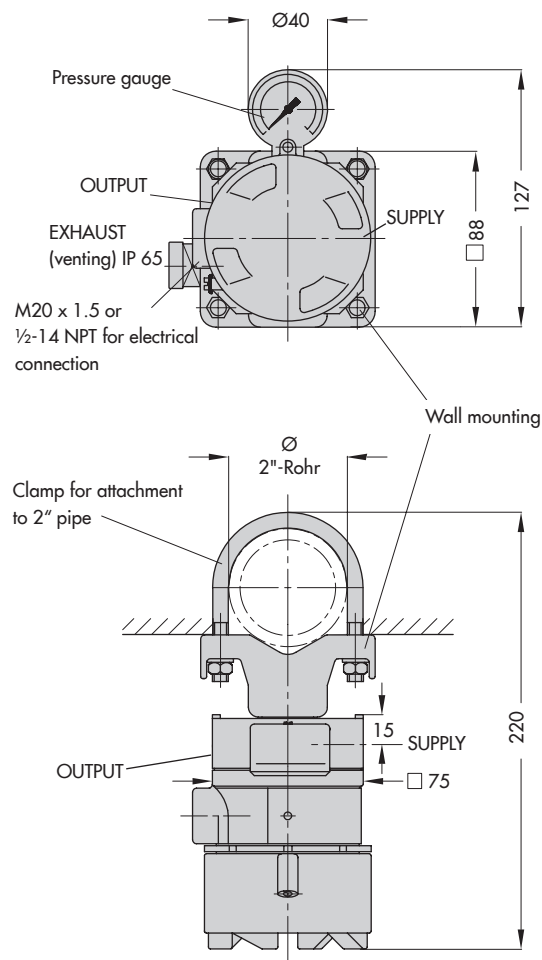

Rear view, without mounting parts

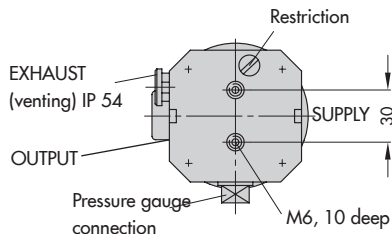

Type 6116-xx06011x000xxxx without booster for positioner attachment

Combined with Type 3766-000 Positioner Accessories, order no. 1400-6227

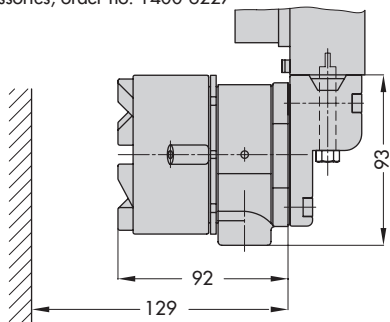

Attachment according to NAMUR with Type 4765 and Type 3760

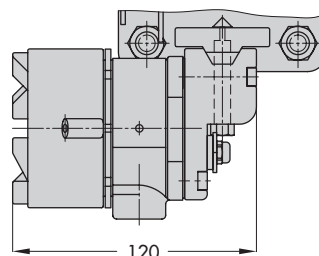

Accessories, order no. 1400-6223 (Type 4765)
 Accessories, order no. 1400-6224 (Type 3760)

Fig. 8: Dimensions

Article code

Order no.	Type 6116-	
Explosion protection	Without	0																	
	Intrinsically safe II 2G Ex ia IIC T6 acc. to ATEX and GOST ^{1) 2)}	1																	
	Flameproof enclosure II 2G Ex d IIC T6 acc. to ATEX and GOST ³⁾	2																	
	Explosion-proof acc. to CSA and FM standards ^{5) 12)}	3																	
	Intrinsically safe according to CSA and FM standards ¹⁾	4																3	
	Explosion proof Ex d IIC T6 acc. to IECEx TSA (Australia) ^{4) 6)}	5																	2
	Intrinsically safe Ex ia/Ex n IIC T6 acc. to IECEx TSA (Australia) ¹⁾ Ex d IIC T6 acc. to JIS standard (Japan) ⁴⁾	6 7	2																
i/p converter module	Type 6109 ⁴⁾	1	0	1					1										
	Type 6112	2																	
Input	4 to 20 mA		0	1															
	4 to 12 mA ^{1) 11)}		2	0	3														
	12 to 20 mA, without switch-off electronics ^{1) 7) 11)}		2	0	4														
	0 to 20 mA, without switch-off electronics ⁷⁾		2	0	5														
	4 to 20 mA, without switch-off electronics ⁷⁾ for positioner attachment		2	0	6														
Output	0.2 to 1.0 bar				0	1													
	3 to 15 psi				0	2													
	0.4 to 2.0 bar	2			0	4													
	6 to 30 psi	2			0	5													
	Special ranges ⁸⁾	Initial value 0.1 to 0.4 bar; span 0.75 to 1.00 bar	2			1	1												
		Initial value 0.1 to 0.4 bar; span 1.00 to 1.35 bar	2			1	2												
		Initial value 0.1 to 0.4 bar; span 1.35 to 1.81 bar	2			1	3												
		Initial value 0.1 to 0.8 bar; span 1.81 to 2.44 bar	2			1	4												
		Initial value 0.1 to 0.8 bar; span 2.44 to 3.28 bar	2			1	5												
Initial value 0.1 to 0.8 bar; span 3.28 to 4.42 bar		2			1	6													
Initial value 0.1 to 1.2 bar; span 4.42 to 5.94 bar		2			1	7													
Initial value 0.1 to 1.2 bar; span 5.94 to 8.00 bar	2			1	8														
Operating direction	Increasing/increasing								1										
	Increasing/decreasing ¹⁾								2										
Electrical connection	½ - 14 NPT									1									
	M20 x 1.5									2									
Pneumatic connection	Positioner attachment (without booster) ⁹⁾		0	6	0	1	1			0	0	0							
	¼ -18 NPT									1									
	ISO-228/1 - G ¼									2									
Degree of protection	Without (vent for positioner attachment)		0	6	0	1	1			0	0	0							
	IP 54										1								
	IP 65										2								
	NEMA 4 ¹⁰⁾										3								
Output pressure gauge	Without																0		
	With ¹⁾																1		
Temperature range	T _{min} ≥ -25 °C (Type 6109, standard)	1																0	
	T _{min} ≥ -45 °C (Type 6112, metal cable gland, subjected to a routine test)	2																1	
	T _{min} ≥ -40 °C (Type 6112, standard)	2																2	
Special version	Without																	0 0 0	
	IECEx approval, Ex d IIC T4/T5/T6 Gb (Type 6116-2)																	2 5 1	
	GOST approval, Ex ia or Ex d (Type 6116-1 or Type 6116-2)																	2 5 2	
	KCS approval, Korea (Type 6116-5)																	2 6 2	

¹⁾ Not for positioner attachment

²⁾ With degree of protection IP 54/IP 65 only

³⁾ Supply pressure max. 6 bar; output 5.6 bar

⁴⁾ Only with 0.2 to 1 bar/3 to 15 psi

⁵⁾ With ½ NPT electrical connection, degree of protection NEMA 4 or positioner attachment

⁶⁾ With ½ NPT electrical connection, degree of protection IP 65 or positioner attachment

⁷⁾ Without switch-off electronics and without potentiometer for zero point and span correction

⁸⁾ Specify setting range, e.g. set to 0.1 to 4 bar; output pressure max. 8 bar. Initial value raised up to 3.0 bar (special version)

⁹⁾ Only with Ex d or explosion-proof according to CSA and FM standards

¹⁰⁾ Only explosion-proof or intrinsically safe according to CSA and FM standards

¹¹⁾ 4 to 12 mA and 12 to 20 mA input only up to 4.0 bar span

¹²⁾ Only with 0.2 to 1 bar/3 to 15 psi and 0.4 to 2 bar/6 to 30 psi output

Accessories

	Order no.
– Wall and pipe mounting	1400-6216
– Mounting bracket (1.4301) for wall mounting	1400-7432
– Mounting unit for Type 6116 in various versions	M6116
– Attachment to Type 3766 ¹⁾	1400-6227
– Attachment to Type 4765 ¹⁾	1400-6223
– Attachment to Type 3760 ¹⁾	1400-6224
– Mounting on cast yoke according to NAMUR ¹⁾	1400-6217
– Mounting on rod-type yoke according to NAMUR ¹⁾	1400-6218
– Male screw fitting G ¼ on hose, 4 mm inside diameter and 6 mm outside diameter, brass	8582-1452
– Male screw fitting ¼ NPT on hose, 4 mm inside diameter and 6 mm outside diameter, brass	8582-1523
– Cable gland M20 x 1.5, blue polyamide (6 to 12 mm clamping range)	8808-1012
– Cable gland M20 x 1.5, nickel-plated brass (6 to 12 mm clamping range)	1890-4875
– Cable gland M20 x 1.5, stainless steel 1.4305 (8 to 14.5 mm clamping range)	8808-0160
– Vent plug G ¼, stainless steel 1.4305, IP 66 (–45 to +80 °C)	1790-7253
– Vent plug G ¼, stainless steel 1.4305, NEMA 4 (–45 to +80 °C)	1790-9646

¹⁾ Only mounting part without assembly and without any possibly required piping. Order together with mounting unit (M6116).

Specifications subject to change without notice



SAMSON AG · MESS- UND REGELTECHNIK
Weismüllerstraße 3 · 60314 Frankfurt am Main, Germany
Phone: +49 69 4009-0 · Fax: +49 69 4009-1507
samson@samson.de · www.samson.de

T 6116 EN

2016-11-22 · English