

Automation System TROVIS 6400

Compact Controller TROVIS 6494



Designed for panel mounting
(dimensions of front frame: 48 mm x 96 mm/ 1.89 inch x 3.78 inch)

Application

Microprocessor-controlled compact controller for automating industrial and process engineering plants.



The TROVIS 6494 Compact Controller is not only suitable for constructing simple control loops, but is also capable of solving highly complex control tasks.

Because of the extremely flexible software design, the user can configure all common control circuit arrangements without having to modify the respective hardware. Hence, the function blocks stored in memory can be adapted to the specific plant configuration.

Special features

- Display panel containing two digital LED displays (red) which, in standard operation, display the controlled process variable x and setpoint $W1$
- Simple operation and configuration via the front panel using six keys
- Universal input options including: Pt 100 or Ni 100 resistance thermometers, or standardized $0(4)$ to 20 mA or $0(2)$ to 10 V signals
- Bumpless transfer (MANUAL/AUTOMATIC mode) in both directions
- All data and parameters stored in non-volatile memory and protected against power failure (EEPROM backup)
- Fully sealed membrane keyboard
- Degree of protection on front side: IP 54
- Humidity Class F according to DIN 40 040
- Selection between units of temperature, either $^{\circ}\text{C}$ or $^{\circ}\text{F}$
- Self-tuning feature
- Two user-selectable internal setpoints ($W1/W2$)
- Standard controller outputs: Continuous, three-step or on-off

Versions

The TROVIS 6494 Compact Controller (Fig. 1) is delivered as a panel-mounted unit according to DIN 43 700 (dimensions of front frame: 48 mm x 96 mm).

TROVIS 6494-01□1

Supply

100 to 253 V AC 1

20 to 30 V AC/DC 2



Fig. 1 · TROVIS 6494 Compact Controller

Design features (Fig. 2)

This compact controller provides one analog input which can be selected as follows:

- Pt 100 resistance thermometer in three-wire circuit with the temperature ranges below:
-30.0 to 150.0 °C or
-100.0 to 400.0 °C.
(resolution comprises 0.1 °C)
- Ni 100 resistance thermometer in three-wire circuit with the temperature ranges below:
-30.0 to 90.0 °C or
-60.0 to 180.0 °C.
(resolution comprises 0.1 °C)
- Standardized 0(4) to 20 mA current signal
- Standardized 0(2) to 10 V voltage signal

The controller's binary input can be used to select between internal setpoints (W1 and W2, resp.) or restart the setpoint ramp with 24 V DC

Input options are selected by appropriate keyboard entry. No hardware configuration is therefore necessary, allowing easy subsequent modification of the input signal when required.

The output signal of the TROVIS 6494 Compact Controller can be optionally chosen as any of the following: Continuous, on-off or three-step. TROVIS 6494 can also be used as a limit switch. In this case, the following output options can be selected:

- Continuous controller output with the standardized 0(4) to 20 mA current signal and two additional AC voltage limit switches (TRIAC)
- Three-step control signal and recorder output of controlled process variable x
- Two AC voltage limit switches (TRIAC) with recorder output of controlled process variable x

After switch has been made to MANUAL operation using the MANUAL/AUTOMATIC key, the controller is able to operate as an open-loop controller. In this case, its output signal can be modified by pressing the corresponding cursor keys.

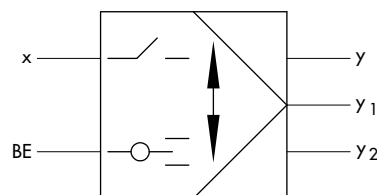

x Controlled process variable x
BE Binary input
y, y1, y2 Controller outputs

Fig. 2 · Block diagram of TROVIS 6494

Technical data

Inputs Analog input Binary input	0 (4) to 20 mA; 0 (2) to 10 V; resistance thermometers Pt 100 or Ni 100 0/24 V DC
Outputs	1 continuous analog output: 0 (4) to 20 mA, load < 650 Ω; On-off or three-step control signal (TRIAC: 24 to 250 V AC; 0.5 A)
Displays	2 four-digit LED display fields (range -1999 to 9999); 3 red LEDs for limit alarms and deviation; 5 yellow LEDs for setpoint W2, MANUAL operation, output variable Y and deviation XD
Configuration	Function blocks stored in memory for fixed setpoint control; changeover between the setpoints W1/W2
Power supply	100 to 253 V AC, 48 to 62 Hz or 20 to 30 VAC/DC (optional)
Power consumption	7 VA
Ambient temperature	0 to 50 °C
Degree of protection	IP 54 (front side), IP 20 (terminals)
Weight	0.3 kg

Operation (Fig. 3)

A three-level operating structure as presented below provides user-friendly operation:

- Operating level
- Parameterization level
- Configuration level

For protection against unintentional or unauthorized access, both the parameterization and configuration level are protected by means of user-definable code numbers.

Operating level

This level is the standard operating level of the controller. The actual value of controlled process variable x is displayed in the top digital LED display (1), and the internal setpoint $W1$ is displayed in the second digital LED display (2). Using the operating key (7), selection can be made in this digital LED display (2) between setpoints ($W1/W2$), deviation (XD) or continuous output (Y).

Parameterization level

To enter the parameterization level, the personal code number must first be entered.

The parameter designations representing modes **P (Proportional)**, **I (Integral)**, **D (Derivative)**, etc. appear in the second digital LED display (2). The numeric values of the parameters can be viewed in the top digital LED display (1) and can be incremented/decremented using the cursor keys (5). After pressing the ENTER key (8), the numeric value in the top digital LED display (1) is stored and accepted.

Configuration level

This level is also protected by means of a code number.

Using the cursor keys (5), the configuration blocks can be selected in any sequence. These blocks can be viewed in the top digital LED display (1). The variable names appear in the second digital LED display (2).

Installation and electrical connection

Panel-mounting unit with two mounting elements for securing in a panel-mounting frame.

Electrical connection: Plug connector for 0.3 to 0.8 mm² leads or optional screw terminals for 0.5 to 1.5 mm² leads.

Ordering text

TROVIS 6494 Compact Controller

With power supply 100 to 253 V AC (or 20 to 30 V AC/DC)

With plug connectors or screw terminals

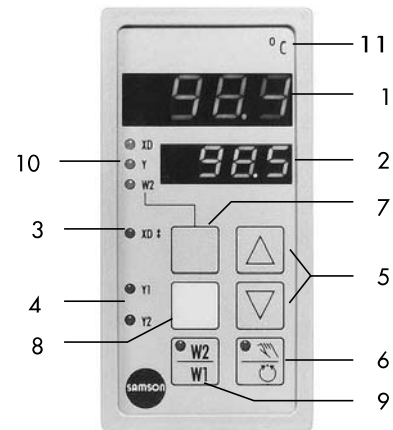

- 1 Top digital LED display with sign
(in standard operation, displays controlled process variable x)
- 2 Second digital LED display with sign
(in standard operation, displays internal setpoint $W1$)
- 3 Deviation
- 4 Relay output display
Three-step/on-off/ limit value
- 5 Cursor keys
- 6 MANUAL/ AUTOMATIC mode selector switch
- 7 Operating key
- 8 ENTER key
- 9 Setpoint changeover switch $W1/W2$
- 10 Display of the selected variable (XD, Y or $W2$)
- 11 Physical unit of temperature

Fig. 3 · Operator panel

Dimensions in mm (inch)

Panel-mounting unit 48 x 96 (1.89 x 3.78)

Panel cut-out: 45^{+0.6} x 92^{+0.8} (1.77^{+0.023} x 3.622^{+0.0315})

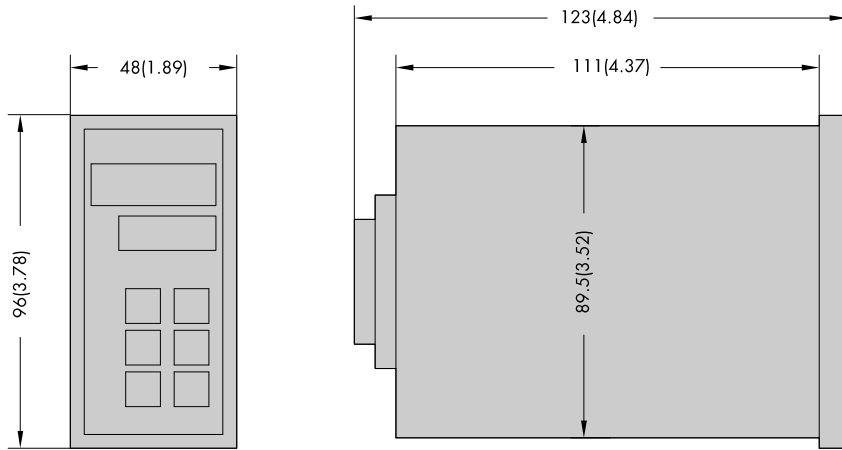

Connection diagram

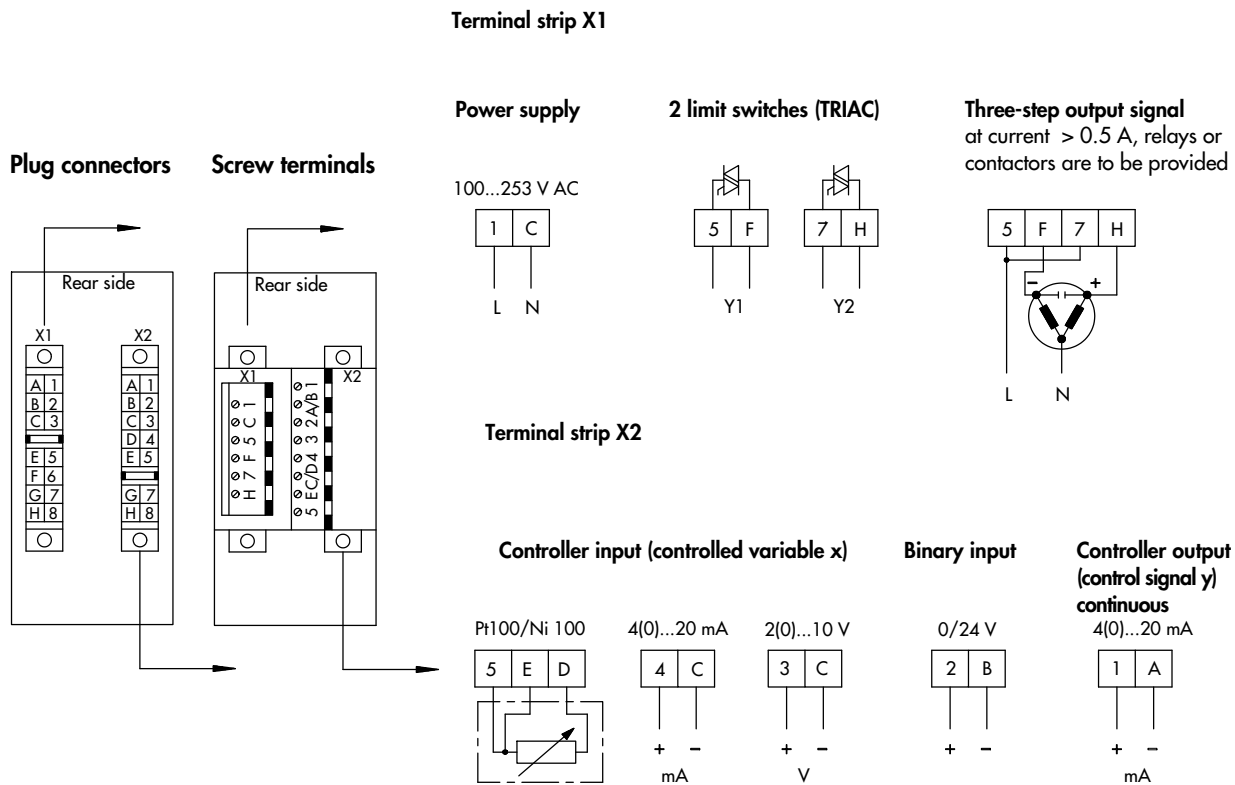

NOTE

When using either a three-step control output or limit switches, the continuous output is available as analog output for controlled process variable x.

Y1 and Y2 can only switch AC voltages. Note, however, correct phase connection.

