

Pneumatic Indicating Controllers for Temperature with Capillary Sensor Type 3430

Controller Station Type 3432 Transmitter Module Type 3436

Application

Temperature controller for process engineering and industrial applications for liquids, gases and vapors · Measuring ranges from -40 to +300 °C



The indicating controllers measure the temperature of the process medium directly, compare the measured value to the set point and produce a pneumatic control signal of 0.2 to 1 bar (3 to 15 psi). The required supply pressure is 1.4 bar (20 psi) or an operating air pressure of 2.0 to 12 bar (30 to 180 psi).

The devices consist of a controller station, a controller module with the desired control mode, and a transmitter module with capillary sensor corresponding to the temperature set point.

Special features

- Controller and control valve form a unit to directly measure the temperature to be controlled that is easy to service and reasonably priced
- Set point, actual value, system deviation and signal pressure are visible at a glance; all required adjusters and switches can be operated on the front panel
- Can be equipped with P, PI, PID or PD controller modules and additional modules for special control tasks
- Housing suitable for wall mounting, pipe mounting and panel mounting (front frame 192 x 228 mm), optionally with lockable door of transparent plastic (IP 65) with conductive coating

Versions

Type 3430 Indicating Controller for Temperature consisting of a Type 3432 Controller Station, a Type 3433 or Type 3434 Controller Module with the desired control mode, and a Type 3436 Transmitter Module

Fixed set point controller (Figs. 2 and 3) · With capillary sensor, measuring ranges from -40 to +300 °C

Follower controller · Same as fixed set point controller, but with additional input for external reference variable $w_{ext} = 0.2$ to 1 bar, 3 to 15 psi or 4 (0) to 20 mA · Without set point adjuster

Fixed set point and follower controller · Combination of fixed set point and follower controller, with w_{int}/w_{ext} selector switch to change between internal and external reference variable

Can optionally be equipped with 1 or 2 adjustable inductive limit switches and/or supply pressure regulator for operating air pressures of 2.0 to 12 bar

Controller stations with i/p converters and limit switches for hazardous locations available on request

See page 4 for details on selecting controller stations and modules.

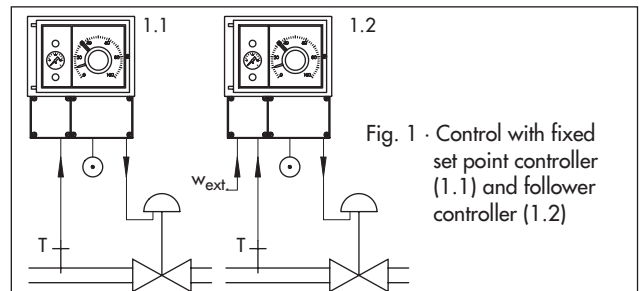

Fig. 1 · Control with fixed set point controller (1.1) and follower controller (1.2)

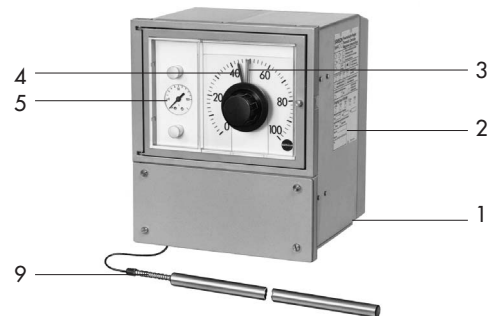

Fig. 2 · Fixed set point controller for temperature with Type 3432-01 Controller Station

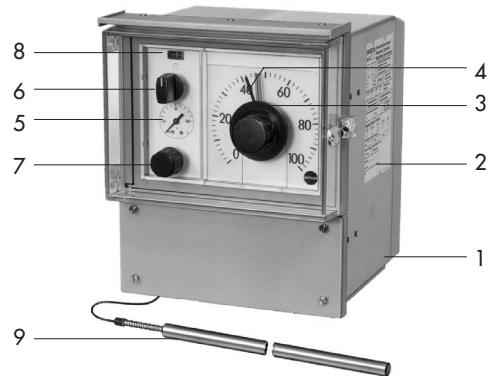

Fig. 3 · Fixed set point controller for temperature with Type 3432-02 Controller Station and lockable door

- | | |
|---|--|
| 1 Controller station | 6 Manual/automatic switch |
| 2 Nameplate | 7 Manual adjuster |
| 3 Set point adjuster with set point display (w) | 8 Differential pressure display for smooth manual/automatic changeover |
| 4 Controlled variable display (x) | 9 Capillary sensor |
| 5 Signal pressure display (y) | |

Principle of operation (see Figs. 4 and 5)

The Series 430 Pneumatic Controllers with their modular design can be used in all kinds of automation applications. The temperature controllers consist of the basic unit – a Type 3432 Controller Station – including a Type 3433 or 3434 Controller Module with the desired control mode and a Type 3436 Transmitter Module. The medium temperature creates a temperature-proportional pressure inside the gas-filled sensor (2.1) of the transmitter module. Using the beam (2.4), this pressure is balanced against a force generated at the feedback bellows (2.6) by the output pressure p_A . The supply air flows through the restrictor (2.9) and nozzle (2.8) onto the flapper (2.7). The flapper moves closer to the nozzle when the temperature increases. As a result, the output pressure p_A applied to the bellows (2.6) rises until a new equilibrium is reached, i.e. until the output signal assumes a value proportional to the temperature. Set zero on the adjustment screw (2.11) and move the feedback bellows to set the span. The temperature-proportional output pressure p_A is applied as a controlled variable signal (x) to the bellows measuring system of the controlled variable display (1.3) and controller module (3).

The controller station (Fig. 4, fixed set point controller) consists of scale (1.2), controlled variable display (1.3), set point adjuster (1.4), and plug-in connections for a controller module (3). These pneumatic connections are self-sealing when the module is unplugged. The controlled variable signal x produces a deflection on the bellows measuring system of the controlled variable display (1.3) which is transmitted to the pointer over a gear mechanism. The set point (reference variable w) can be adjusted on a scale (1.2) at the controller front. The position of the set point adjuster is transmitted to the set point transmitter (1.4) over a gear mechanism. This servo system (1.41) converts the adjusted set point into a pneumatic set point signal (w), which is fed to the controller module. The controller module compares the controlled variable signal and the set point signal (x and w) and produces an output signal y_A depending on the system deviation and the adjusted control parameters. The output signal is connected to the output signal display (1.5) and output y.

The controller station in Fig. 5 largely corresponds to the one shown in Fig. 4. However, it additionally contains a manual/automatic switch (1.6), manual adjuster (1.7), and differential pressure display (1.8). When the switch is in position AUTOMATIC, the output signal display (1.5) and output y are connected to the automatic output signal y_A . In position MANUAL, the output signal display and output y are connected to the manual output signal y_H set at the adjuster. Smooth changeover from manual to automatic operation is possible when the differential pressure display indicates that y_A and y_H are identical.

The follower controllers not shown here have an additional pneumatic or electric input for the external reference variable w_{ext} (at input $w_{ext} = 4$ (0) to 20 mA with integrated i/p converter). Refer to T 7045 EN for details on the i/p converter.

The stations can be equipped with suitable controller modules, e.g. Type 3434 for common P or PI temperature control, Type 3433 for P, PI, PID and PD control, and additional modules for special control tasks. Refer to T 7040 EN and T 7041 EN.

The stations can be equipped with 1 or 2 inductive limit switches adjustable on the scale. They are also available with supply pressure regulator (1.9, Fig. 5.1) enabling them to be used for operating air pressures from 2 to 12 bar. The supply pressure regulator reduces the operating air pressure (p_B) to the required supply pressure (p_Z) of 1.4 bar or 20 psi.

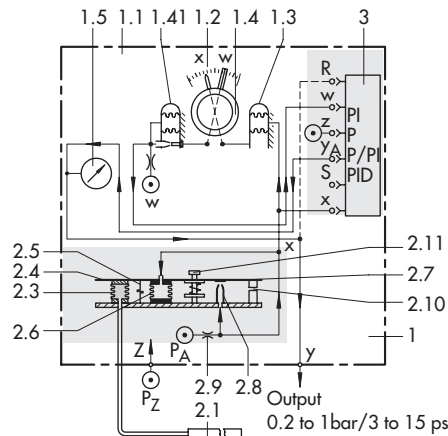
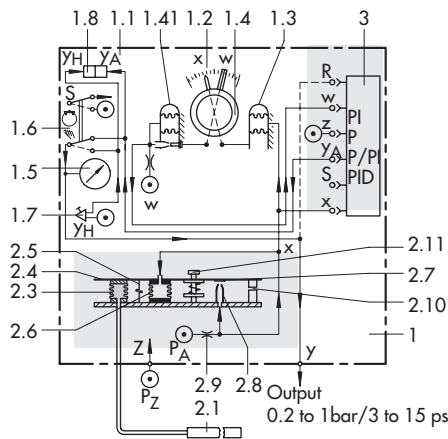

Fig. 4 · Fixed set point controller for temperature, version with Type 3432-01 Controller Station, functional diagram



5.1

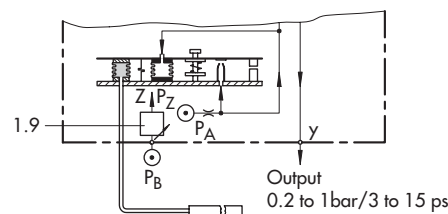

Fig. 5.1 · Version with supply pressure regulator (1.9)

Fig. 5 · Fixed set point controller for temperature, version with Type 3432-02 Controller Station, functional diagram

- | | | | |
|-----|---|------|---|
| 1 | Controller station | 1.9 | Supply pressure regulator |
| 1.1 | Housing with door | 2 | Transmitter module for temperature |
| 1.2 | Scale | 2.1 | Sensor |
| 1.3 | Controlled variable display with pointer, gear mechanism, and bellows measuring system | 2.2 | Capillary tube |
| 1.4 | Set point adjuster with pointer, gear mechanism, and set point transmitter (1.41); follower controllers: set point display only | 2.3 | Measuring bellows |
| 1.5 | Output signal display | 2.4 | Beam |
| 1.6 | Manual/automatic switch | 2.5 | Universal joint |
| 1.7 | Manual adjuster | 2.6 | Feedback bellows |
| 1.8 | Differential pressure display for smooth manual/auto changeover | 2.7 | Flapper |
| | | 2.8 | Nozzle |
| | | 2.9 | Restrictor |
| | | 2.10 | Damper |
| | | 2.11 | Zero adjuster |
| | | 3 | Controller module |

The supply pressure regulator's principle of operation corresponds to Type 3708-5003 described in T 8545 EN.

Table 1 · Technical data

Type 3436 Transmitter Module										
Measuring range (standard)		-20 to +30 °C 0 to +50 °C		0 to +100 °C 50 to +150 °C		0 to 150 °C		0 to 200 °C		
Special measuring ranges Lower range value		+150 to +250 °C -40 to +150 °C		-40 to +200 °C		-40 to +150 °C		-40 to +100 °C		
Measuring span		50 K		100 K		150 K		200 K		
Overload limit		350 °C								
Perm. pressure at the sensor		Without thermowell PN 16 · With thermowell PN 63 or PN 100								
Supply pressure		1.4 ±0.1 bar (20 ±1.5 psi)								
Output		0.2 to 1.0 bar (3 to 15 psi)								
Deviation		0.6 % from terminal-based conformity (fixed set point)								
Hysteresis		< 0.25 %								
Effects	Supply air	< 0.25 %/0.1 bar								
	Pressure at the sensor	< 0.6 %/10 bar		< 0.25 %/10 bar		< 0.15 %/10 bar				
	Ambient temperature	< 0.6 %/°C		< 0.03 %/°C						
Capillary tube		Length 3 m or 6 m · With/without metal protective hose · Filling medium: Nitrogen								
Type 3432 Controller Station										
Controlled variable display		Measuring range 0.2 to 1.0 bar (3 to 15 psi) · Accuracy Class 1.6 · Scale length 212 mm								
Set point adjustment ¹⁾		Output 0.2 to 1.0 bar (3 to 15 psi) · Scale length 212 mm · Accuracy Class 1.6								
Manual adjuster		Output 0.2 to 1.0 bar (3 to 15 psi) · Max. 0.02 to 1.35 bar · Max. air delivery > 1.5 m ³ /h								
Inductive limit switches		1 or 2 SC 3,5-NO-YE proximity switches acc. to DIN EN 60947-5-6, Ex II 2 G EEx ia IIC T6								
i/p converter ²⁾		Input 4 (0) to 20 mA (R _i = 200 Ω)								
Can be equipped with ...										
Controller Module ³⁾	Type	3434-1	3434-2	3433-1	3433-2	3433-3	3433-4	3433-5	3433-6	3433-9
Control mode		P	PI	P	PI ⁴⁾	PID ⁴⁾	PD	P/PI	PD/PID	P ⁵⁾
Prop.-action coef. K _p		1 to 20		0.2 to 20 (0.4 to 40)						
Reset time T _n		-	0.05-20 min	0.03 to 50 min						
Derivative-action time T _v		-	-	0.01 to 10 min · Derivative-action gain x ≈ 10						
Additional module (optional) ³⁾	Type	-		3437-1 Signal limiter	3437-2 Mode changeover	3437-3 Smooth manual/automatic changeover				
Output		0.2 to 1 bar (3 to 15 psi) · Max. 0.02 to 1.35 bar								
Supply air	Standard version	Supply pressure 1.4 bar (20 psi) · Air consumption < 0.6 m ³ /h								
	W. supply press. regulator	Operating air pressure 2.0 to 12 bar (30 to 180 psi) · Air consumption < 0.75 m ³ /h								
	With i/p converters	w _{ext} +0.13 m ³ /h								
Air quality acc. to ISO 8573-1		Max. particle size and density: Class 3 · Oil content: Class 2 · Pressure dew point: Class 3 or at least 10 K beneath the lowest ambient temperature to be expected								
Perm. ambient temperature		-20 °C to +60 °C (-40 °C to +60 °C on request)								
Degree of protection		IP 40, front with door: IP 65								
Overall weight, approx.		6 kg								

¹⁾ Version with follower controller: only set point display with 212 mm scale · ²⁾ For details see T 7045 EN

³⁾ For details see T 7040 EN and T 7041 EN · ⁴⁾ Optionally with feedback limitation · ⁵⁾ With set point dependent operating point

Table 2 · Materials (material no. according to DIN EN)

Capillary sensor ¹⁾	Stainless steel 1.4571
Housing	Die-cast aluminum, plastic coated

¹⁾ As bulb sensor Ø 12 mm · Optionally, temperature sensor for air (outside Ø 20 mm) or temperature sensor for installation in T-union according to DIN 11857

Ordering text

Pneumatic Indicating Controller for Temperature
Type 3432-... / 3436

With Type 3434-... /3433-... Controller Module

Measuring range ... °C, measuring span ... °C

Control mode P, PI, PID, P/PI, PD/PID, P set point dependent as fixed set point controller/follower controller/fixed set point and follower controller

Output 0.2 to 1 bar/3 to 15 psi

Capillary tube 3/6 m long, with/without protective hose

Optionally, special version..., accessories, ...

Table 3 · Controller station versions

Controller Station	Type	3432-...											
		01		02		03		04		05		06	
Fixed set point control		•		•									
Follow-up control						•		•					
Fixed set point + follow-up control										•		•	
Can be equipped with ...													
Set point adjuster		•		•						•		•	
Set point display		•		•		•		•		•		•	
Controlled variable and output signal display		•		•		•		•		•		•	
Manual/automatic switch				•				•				•	
Manual adjuster and differential pressure display				•				•				•	
Selector switch w_{int}/w_{ext}										•		•	
Transmitter module		•		•		•		•		•		•	
Controller Type 3433-... ¹⁾			•		•		•		•		•		•
Module Type 3434-...		•		•		•		•		•		•	
Input w_{ext}	0.2 to 1 bar					•	•	•	•	•	•	•	•
	4 (0) to 20 mA						•		•		•		•
i/p converter for w_{ext}						•		•		•		•	
Can additionally be equipped with ...													
1 or 2 inductive limit switches		•	•	•	•	•	•	•	•	•	•	•	•
Type 3708-5003 Supply Pressure Regulator		•	•	•	•	•	•	•	•	•	•	•	•
Door IP 65, conductive coating		•	•	•	•	•	•	•	•	•	•	•	•

¹⁾ Optionally with additional module

Electrical connection

When additionally equipped with i/p converter for w_{ext} and/or inductive limit switches

Terminals for 0.5 to 1.5 mm² wires

Connect suitable switching amplifiers into the output circuit to operate inductive limit switches.

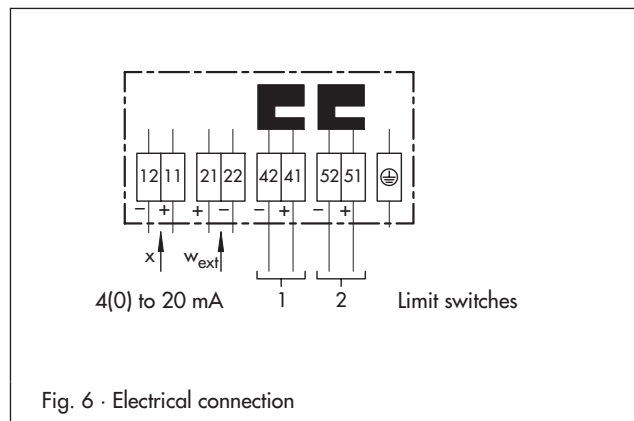
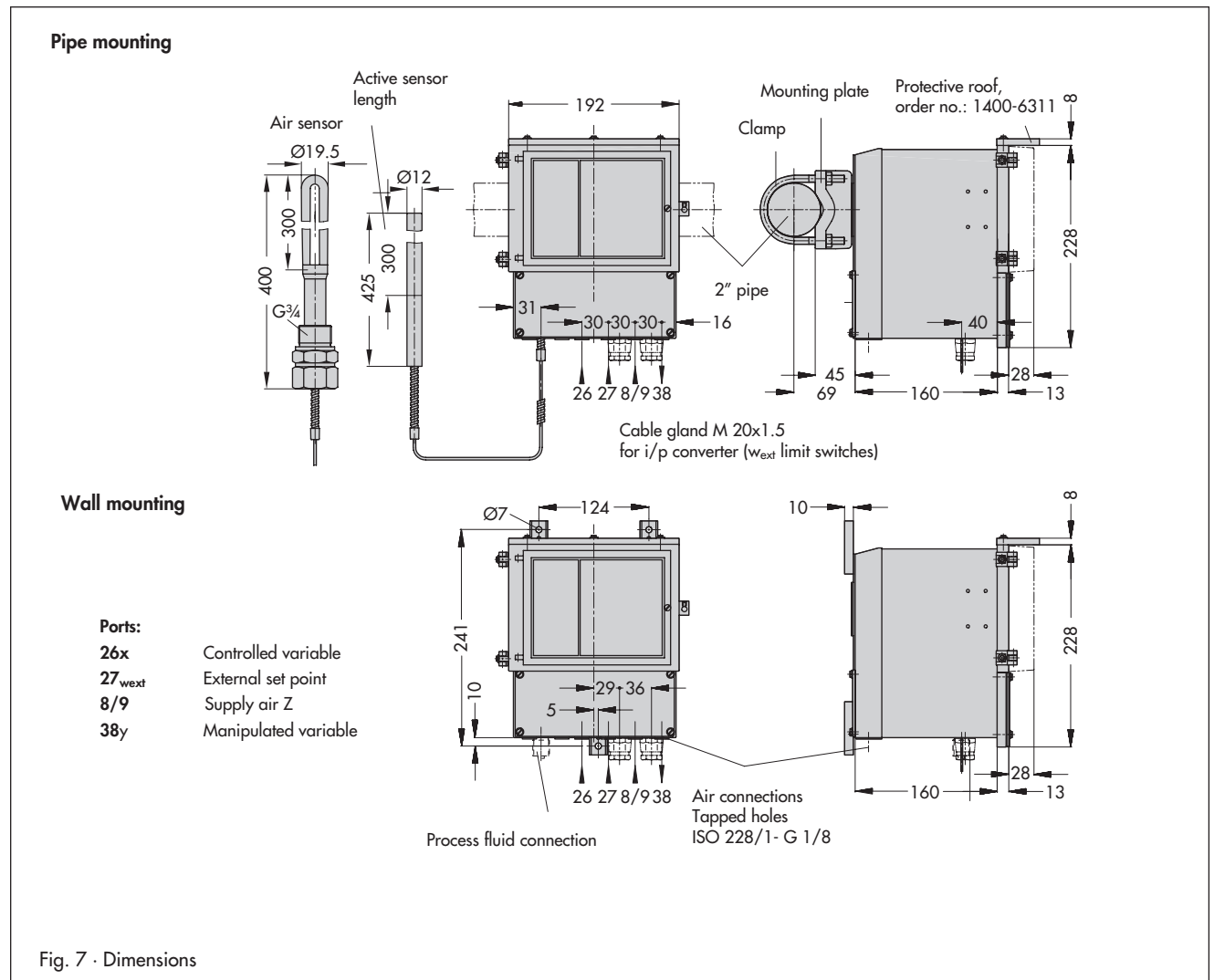

Fig. 6 · Electrical connection

Dimensions in mm



Installation and connections

The following mounting positions are possible:

Pipe mounting · With fastening element and clamp for attachment to horizontal and vertical 2" pipes (order no. 1400-6302)

Wall mounting · With three brackets for attachment to a wall (order no. 1400-6301)

Panel mounting · With four C DIN 43835 fastening elements for attachment to the control panel · Cut-out for panel mounting 188⁺¹ x 255⁺¹ mm · Distance between center lines with door approx. 235 mm · Close-to-close arrangement in rows (without door) according to DIN 43700 (order no. 1400-6300)

Mounting position · Controller station mounted in the upright position.

Pneumatic connections (output and supply) · ISO 228/1-G 1/8 tapped holes

Bulb sensor Ø 12mm, length 425 mm, active length 300 mm

The bulb sensor can be installed in any desired position. Its entire length must be immersed in the process medium. Choose a place of installation where neither overheating nor considerable dead times occur. Make sure no temperature fluctuations occur (ambient temperature approx. 20 °C). Install the capillary tube such that no mechanical damage can occur. The smallest permissible bending radius is 50 mm.

Accessories are part of the controller and must be ordered separately. Select accessories according to the operating conditions at the point of measurement. Materials of screw glands and thermowells: all wetted parts are made of stainless steel (1.4571).

Fastening parts for bulb sensor $d = 12 \text{ mm}$, 425 mm long, active length 300 mm

Clamping flange

for wall mounting, e.g. depressurized tanks, ducts, etc.

Order no. 1090-9547

Fasten the flange with two screws to the side and fasten the temperature sensor using two other screws in the flange.

Screw gland (PN 10)

G 1/2 Order no. 1080-4881

G 3/4 Order no. 1080-4882

Apply sealant to the screw gland. Push in sensor with screw gland and coupling nut. Tighten coupling nut

Screw gland (PN 40) with clamping nut

G 1/2 Order no. 1080-4884

G 3/4 Order no. 1080-4885

Mount as above, tighten clamping nut in place of the coupling nut.

Screw-in thermowell (PN 63)

G 1/2 Order no. 1080-4888

G 3/4 Order no. 1080-4889

A thermowell is recommended on exceeding the nominal pressure, or with corrosive media or when the plant is to remain in operation on changing the sensor.

Push sensor as far as it will go into the thermowell and tighten coupling nut.

Weld-in thermowell (PN 63)

Order no. 1080-4890

Thermowell with flange

Order no. 1080-4891 (PN 40)

1080-4892 (PN 100)

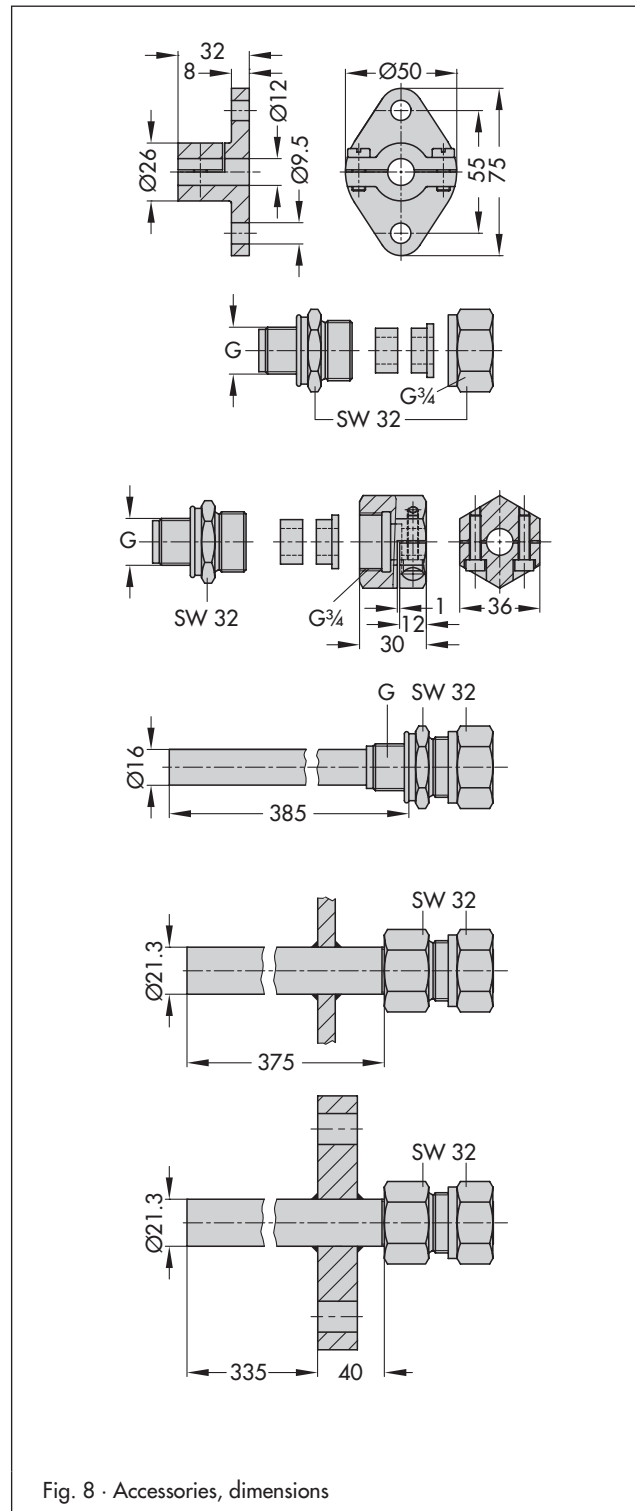

Fig. 8 · Accessories, dimensions

Specifications subject to change without notice



SAMSON AG · MESS- UND REGELTECHNIK
 Weismüllerstraße 3 · 60314 Frankfurt am Main · Germany
 Phone: +49 69 4009-0 · Fax: +49 69 4009-1507
 Internet: <http://www.samson.de>

T 7034 EN