

Pneumatic Indicating Controllers for Standardized Signals Type 3430

Controller Stations Type 3431 and Type 3432

Application

Controller for standardized signals connected to pneumatic or electric transmitters for process engineering and industrial applications · Input 0.2 to 1 bar (3 to 15 psi) · 4 (0) to 20 mA



The controllers measure the electric or pneumatic standardized signal of a transmitter, indicate the operating value, compare the measured value to the set point and produce a pneumatic control signal of 0.2 to 1 bar (3 to 15 psi). The required supply pressure is 1.4 bar (20 psi) or an operating air pressure of 2.0 to 12 bar (30 to 180 psi).

The devices consist of a controller station and a controller module with the desired control mode.

Special features

- Easy-to-service and reasonably priced automation units
- Set point, actual value, system deviation and signal pressure are visible at a glance; all required adjusters and switches can be operated on the front panel
- Can be equipped with P, PI, PID or PD controller modules and additional modules for special control tasks
- Housing suitable for wall mounting, pipe mounting and panel mounting (front frame 192 x 144 mm or 192 x 228 mm), optionally with lockable door of transparent plastic (IP 65) with conductive coating

Versions

Type 3430 Indicating Controller for standardized signals consisting of a Type 3431 or Type 3432 Controller Station and a Type 3433 or Type 3434 Controller Module with the desired control mode

Fixed set point controller (Figs. 2 and 3) · With input 0.2 to 1 bar, 3 to 15 psi or 4 (0) to 20 mA

Follower controller · Same as fixed set point controller, but with additional input for external reference variable $w_{ext} = 0.2$ to 1 bar, 3 to 15 psi or 4 (0) to 20 mA · Without set point adjuster

Fixed set point and follower controller · Combination of fixed set point and follower controller, with $w_{int}/w_{ext}^{1)}$ selector switch to change between internal and external reference variable

Can optionally be equipped with transmitter module with 1 or 2 adjustable inductive limit switches and/or supply pressure regulator¹⁾ for operating air pressures of 2.0 to 12 bar

Controller stations with i/p converters and limit switches in type of protection EEx ia IIC available on request

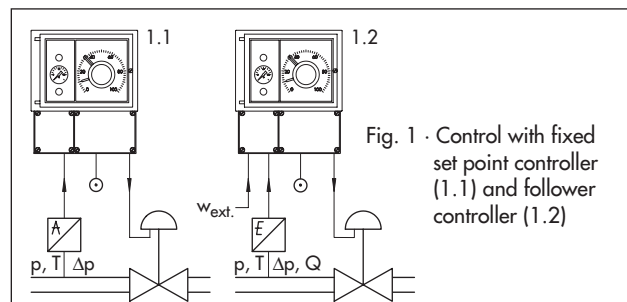

Fig. 2 · Fixed set point controller for standardized signals with Type 3432-01 Controller Station

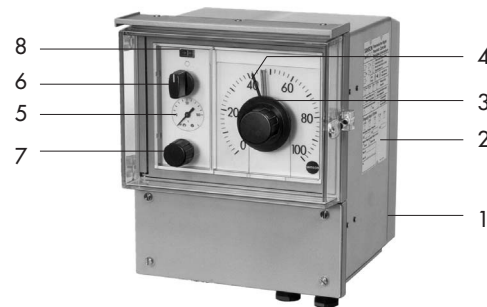

Fig. 3 · Fixed set point controller for standardized signals with Type 3432-02 Controller Station and lockable door

- | | |
|---|--|
| 1 Controller station | 6 Manual/automatic switch |
| 2 Nameplate | 7 Manual adjuster |
| 3 Set point adjuster with set point display (w) | 8 Differential pressure display for smooth manual/automatic changeover |
| 4 Controlled variable display (x) | |
| 5 Signal pressure display (y) | |

¹⁾ Only with Type 3432 Controller Station

See page 5 for details on selecting controller stations and modules.

Principle of operation (see Figs. 4 to 7)

The Series 430 Pneumatic Controllers with their modular design can be used in all kinds of automation applications.

The controllers for standardized signals consist of the basic unit – a Type 3431 or Type 3432 Controller Station – including a Type 3433 or 3434 Controller Module with the desired control mode.

The pneumatic standardized signal (controlled variable x) is fed to the bellows measuring system of the controlled variable display (1.3) and the controller module (3).

The controller station (fixed set point controller with pneumatic input) shown in Fig. 4 consists of scale (1.2), controlled variable display (1.3), set point adjuster (1.4), and plug-in connections for a controller module (3). These pneumatic connections are self-sealing when the module is unplugged. The controlled variable signal x produces a deflection on the bellows measuring system of the controlled variable display (1.3) which is transmitted to the pointer over a gear mechanism. The set point (reference variable w) can be adjusted on a scale (1.2) at the controller front. The position of the set point adjuster is transmitted to the set point transmitter (1.4) over a gear mechanism. This servo system (1.41) converts the adjusted set point into a pneumatic set point signal (w), which is fed to the controller module. The controller module compares the controlled variable signal and the set point signal (x and w) and produces an output signal y_A depending on the system deviation and the adjusted control parameters. The output signal is connected to the output signal display (1.5) and output y .

The controller station shown in Fig. 5 largely corresponds to the version shown in Fig. 4. However, the station additionally contains a manual/automatic switch (1.6), a manual adjuster (1.7), and a differential pressure display (1.8). When the switch is in position AUTOMATIC, the output signal display (1.5) and output y are connected with the automatic output signal y_A . When the switch is in position MANUAL, the output signal display and output y are connected to the manual output signal y_H set at the adjuster. Smooth changeover from manual to automatic operation is possible when the differential pressure display indicates that y_A and y_H are identical. The follower controllers are not equipped with a set point adjuster (1.4); they come with a set point display. The version shown here includes a pneumatic input for the external reference variable w_{ext} .

The Type 3432 Controller Station for combined fixed set point and follow-up control is equipped with an additional unit (1.10). It contains a w_{int}/w_{ext} selector switch, a set point adjuster, and a differential pressure display (Fig. 6). Smooth changeover from manual to automatic operation is possible when the differential pressure display indicates that w_{int} and w_{ext} are identical.

- | | | | |
|------|---|------|---|
| 1 | Controller station | 1.8 | Differential pressure display for smooth manual/automatic changeover |
| 1.1 | Housing with door | 1.9 | Supply pressure regulator |
| 1.2 | Scale | 1.10 | Additional unit with w_{int}/w_{ext} switch, set point adjuster and differential pressure display |
| 1.3 | Controlled variable display with pointer, gear mechanism and bellows measuring system | 2 | i/p converter |
| 1.4 | Set point adjuster with pointer, gear mechanism and set point transmitter (1.41); follower controller: set point display only | 3 | Controller module |
| 1.41 | Servo system | | |
| 1.5 | Signal pressure display | | |
| 1.6 | Manual/automatic switch | | |
| 1.7 | Manual adjuster | | |

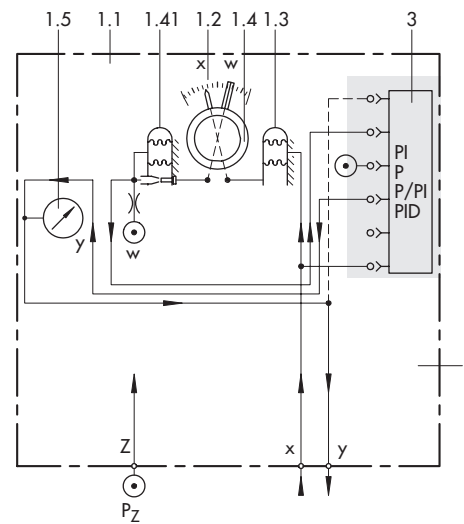

Fig. 4 · Fixed set point controller for pneumatic standardized signals, version with Type 3431-01, functional diagram

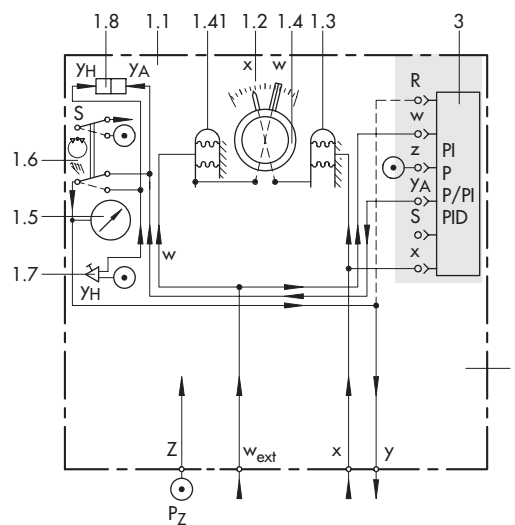

Fig. 5 · Follower controller for pneumatic standardized signals and pneumatic input for w_{ext} , version with Type 3431-04 Controller Station, functional diagram

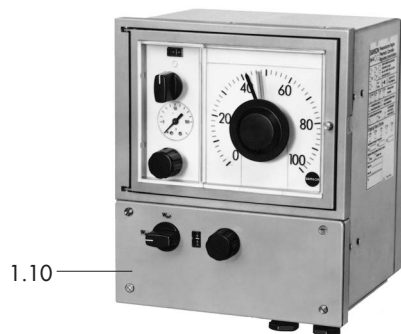

Fig. 6 · Fixed set point and follower controller with additional unit (1.10) to switch between internal and external reference variable, version with Type 3432-06 Controller Station

The versions with i/p converter (Fig. 7) are designed for connection of 4 to 20 mA or 0 to 20 mA electric input signals (controlled variable x). The standardized input signal of a transmitter is fed to the i/p converter (2) and converted into a pneumatic standardized signal from 0.2 to 1 bar. The controller stations largely correspond to the versions shown in Figs. 4, 5, and 6. However, the stations additionally contain an i/p converter (2) whose output signal is applied to the bellows measuring system of the controlled variable display (1.3) and the controller module (3). Follower controller with electric input $w_{ext} = 4$ to 20 mA or 0 to 20 mA are equipped with an additional i/p converter. The controller stations can be equipped with various controller modules, e.g. with Type 3434 for common P or PI control, with Type 3433 for P, PI, PID and PD control as well as with additional modules for special control tasks. For details on the controller modules refer to Data Sheets T 7040 EN and T 7041 EN. The controller stations can optionally be equipped with 1 or 2 adjustable inductive limit switches.

Supply pressure regulator

Optionally, the versions with Type 3432 Controller Station are also available with a supply pressure regulator (1.9, see Fig. 7.1), enabling the stations to be used for operating air pressures from 2.0 to 12 bar. The additional supply pressure regulator controls and reduces the operating air pressure (p_B) to the required supply pressure (p_Z) of 1.4 bar or 20 psi. The regulator's principle of operation corresponds to Type 3708-5003 described in Data Sheet T 8545 EN.

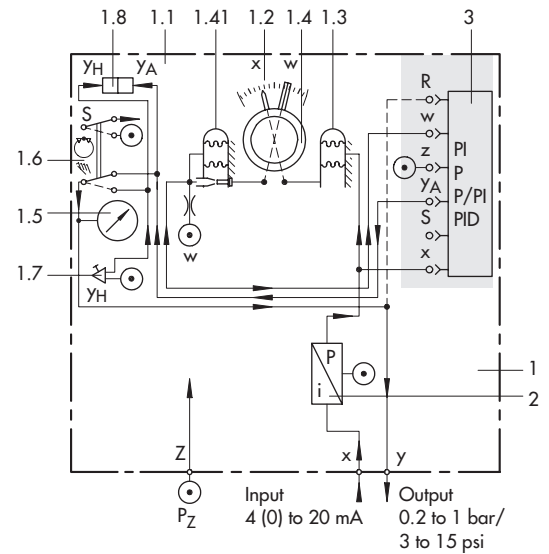

Fig. 7 · Fixed set point controller for electric standardized signals, version with Type 3431-02 Controller Station

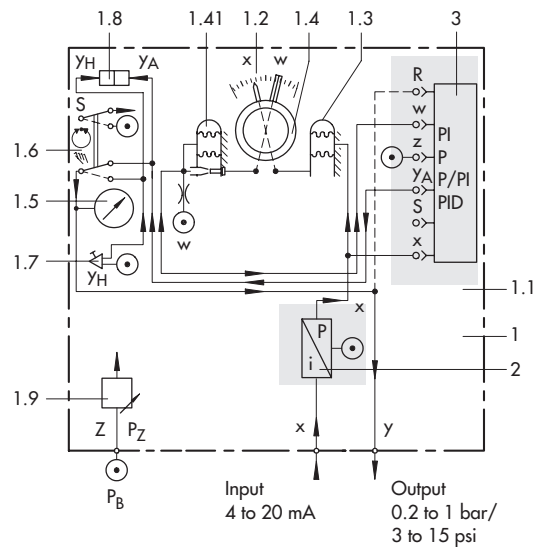

Fig. 7.1 · Version with supply pressure regulator (1.9)

Table 1 · Technical data for standardized signal controllers

Input x and w _{ext}	0.2 to 1.0 bar, 3 to 15 psi, 4 (0) to 20 mA									
Type 3431 and Type 3432 Controller Stations										
Controlled variable display	Measuring range 0.2 to 1.0 bar (3 to 15 psi) · Accuracy Class 1.6 · Scale length 212 mm									
Set point adjustment ¹⁾	Output 0.2 to 1.0 bar (3 to 15 psi) · Scale length 212 mm · Accuracy Class 1.6									
Manual adjuster	Output 0.2 to 1.0 bar (3 to 15 psi) · Max. 0.02 to 1.35 bar · Max. air delivery > 1.5 m ³ /h									
Inductive limit switches	1 or 2 SC 3,5-NO-YE proximity switches acc. to DIN EN 60947-5-6, Ex II 2 G EEx ia IIC T6									
i/p converter for x and/or w _{ext} ²⁾	Input 4 (0) to 20 mA (R _i = 200 Ω)									
Can be equipped with ...										
Controller Module ³⁾	Type	3434-1	3434-2	3433-1	3433-2	3433-3	3433-4	3433-5	3433-6	3433-9
Control mode		P	PI	P	PI ⁴⁾	PID ⁴⁾	PD	P/PI	PD/PID	P ⁵⁾
Prop.-action coef. K _p		1 to 20		0.2 to 20 (0.4 to 40 on request)						
Reset time T _n		–	0.05 to 20 min	0.03 to 50 min						
Derivative-action time T _v		–	–	0.01 to 10 min · Derivative-action gain x ≈ 10						
Additional module (optional) ³⁾	Type	–		3437-1 signal limiter		3437-2 mode changeover		3437-3 smooth manual/automatic transfer		
Output	0.2 to 1 bar (3 to 15 psi) · Max. 0.02 to 1.35 bar									
Supply air	Standard version	Supply pressure 1.4 bar (20 psi) · Air consumption < 0.6 m ³ /h								
	W. supply press. regulator	Operating air pressure 2.0 to 12 bar (30 to 180 psi) · Air consumption < 0.75 m ³ /h								
	With i/p converters	w _{ext} +0.13 m ³ /h								
Air quality acc. to ISO 8573-1	Max. particle size and density: Class 3 · Oil content: Class 2 · Pressure dew point: Class 3 or at least 10 K beneath the lowest ambient temperature to be expected									
Perm. ambient temperature	–20 °C to +60 °C (–40 °C to +60 °C on request)									
Degree of protection	IP 40, front with door: IP 65									
Overall weight, approx.	6 kg									
Materials										
Housing	Die-cast aluminum, plastic coated									

- 1) Version with follower controller: only set point display with 212 mm scale
- 2) For details see Data Sheet T 7045 EN
- 3) For details see Data Sheets T 7040 EN and T 7041 EN
- 4) Optionally with feedback limitation
- 5) With set point dependent operating point

Electrical connection

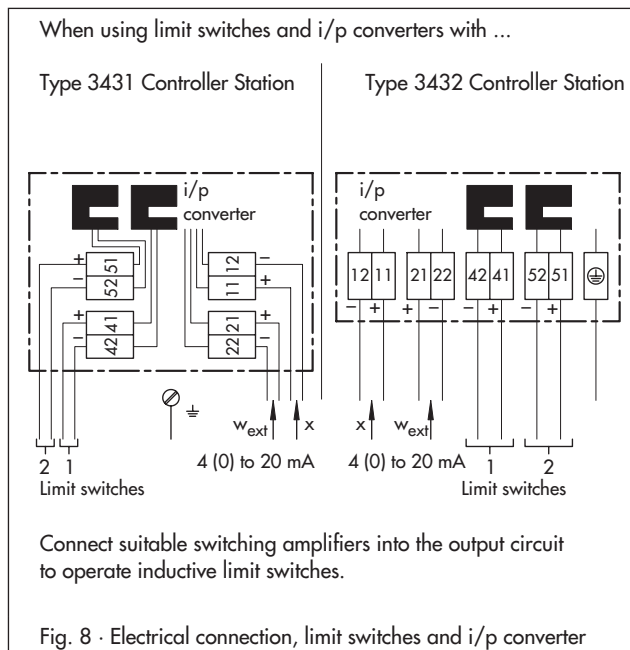

Ordering text

Pneumatic Indicating Controller for Standardized Signals with Type 3431-.../3431-... Controller Station

Input x:

0.2 to 1 bar/ 3 to 15 psi/ 4 to 20 mA/ 0 to 20 mA

Input w_{ext} for follower controllers:

0.2 to 1 bar/ 3 to 15 psi/ 4 to 20 mA/ 0 to 20 mA

Optionally, with lockable door/with 1 or 2 inductive limit switches

With supply pressure regulator (only with Type 3432)

With Type 3433-.../3434-... Controller Module

Optionally, with Type 3437-... Additional Module (only with Type 3433)

Table 2 · Controller station versions

Controller Station	Type	3431-...				3432-...					
		01	02	03	04	01	02	03	04	05	06
Without explosion protection		01	02	03	04	01	02	03	04	05	06
With explosion protection		11	12	13	14	11	12	13	14	15	16
Fixed set point control		•	•			•	•				
Follow-up control				•	•			•	•		
Fixed set point and follow-up control										•	•
Can be equipped with ...											
Set point adjuster		•	•			•	•			•	•
Set point display		•	•	•	•	•	•	•	•	•	•
Controlled variable and signal pressure display		•	•	•	•	•	•	•	•	•	•
Manual/automatic switch			•		•		•		•		•
Manual adjuster and differential pressure display			•		•		•		•		•
w _{int} /w _{ext} selector switch										•	•
Controller	Type 3433-... ¹⁾	•	•	•	•	•	•	•	•	•	•
Module	Type 3434-...	•	•	•	•	•	•	•	•	•	•
Input x	0.2 to 1 bar	•	•	•	•	•	•	•	•	•	•
	4 (0) to 20 mA (i/p converter)	•	•	•	•	•	•	•	•	•	•
Input w _{ext}	0.2 to 1 bar			•	•	•	•		•	•	•
	4 (0) to 20 mA (i/p converter)			•	•				•	•	•
Can additionally be equipped with ...											
1 or 2 inductive limit switches		•	•	•	•	•	•	•	•	•	•
Type 3708-5009 Supply Pressure Regulator						•	•	•	•	•	•
Lockable transparent door, IP 65, with conductive coating		•	•	•	•	•	•	•	•	•	•

1) Optionally with additional unit

Installation and connections (see Fig. 9)

Mounting position · Controller station in upright position

Pipe mounting · With fastening element and clamp for attachment to horizontal and vertical 2" pipes

Wall mounting · With three brackets for attachment to a wall

Panel mounting · With four C DIN 43835 fastening elements for panel mounting

Air connections · ISO 228/1- G 1/8 tapped holes

Electrical connection · Terminals for 0.5 to 1.5 mm² wires

Dimensions in mm

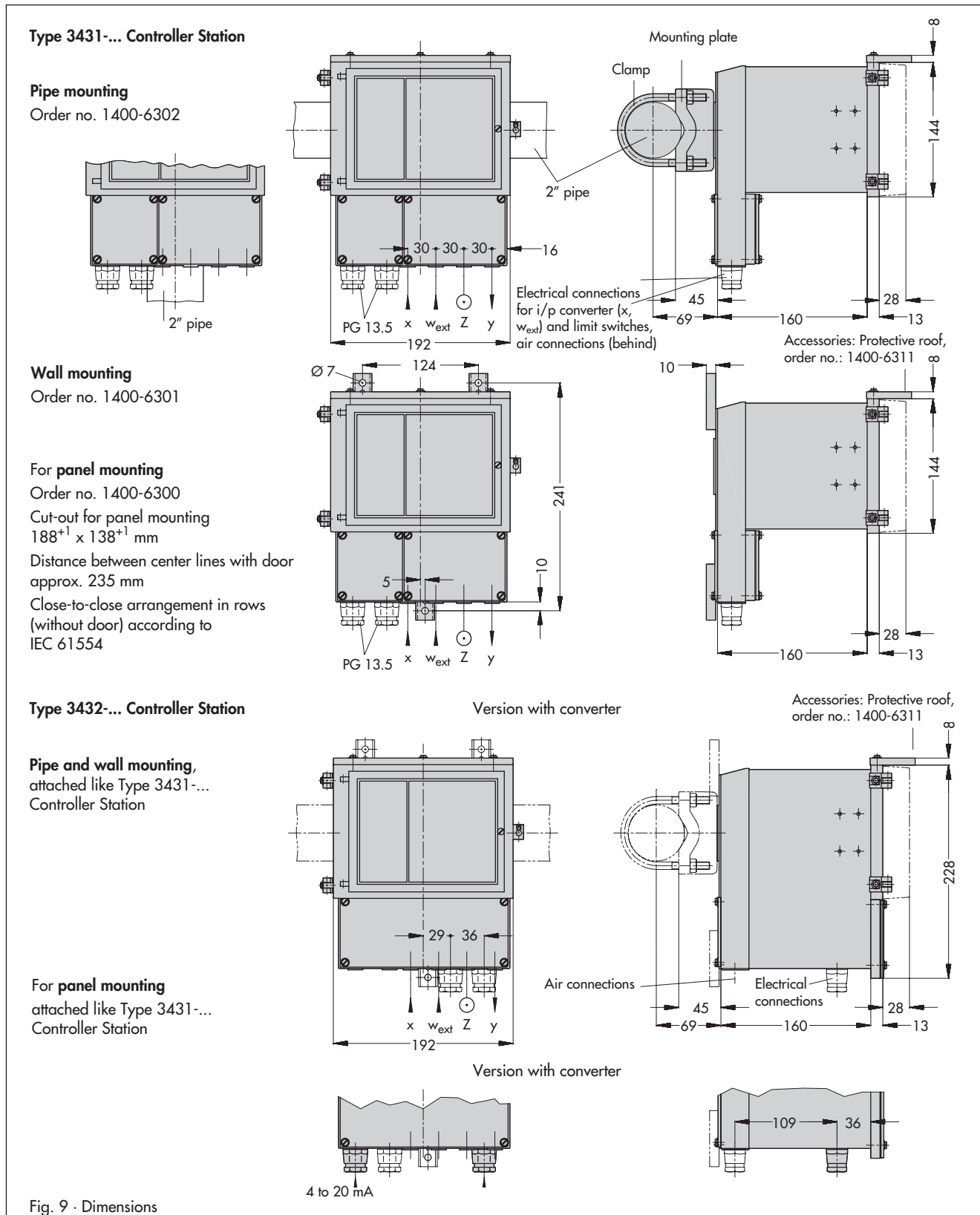

Specifications subject to change without notice



SAMSON AG · MESS- UND REGELTECHNIK
Weismüllerstraße 3 · 60314 Frankfurt am Main · Germany
Phone: +49 69 4009-0 · Fax: +49 69 4009-1507
Internet: <http://www.samson.de>

T 7038 EN