

Application

Low-priced controller modules for the installation in Type 3430 Pneumatic Controllers

The Type 3434 Controller Module is designed for input and output signals from 0.2 to 1 bar (3 to 15 psi) as well as a supply pressure of 1.4 bar (20 psi).

The plugs of the controller module fit into the self-sealing connectors of the controller station, where they are held by a fastening screw.

Versions

The controller modules are equipped with a box-shaped comparator operating according to the force-balance principle. The proportional-action coefficient K_p can be adjusted on a restrictor between 1 and 20.

Type 3434-1 (Fig. 1) · Controller module for P control action with fixed operating point

Type 3434-2 (Fig. 2) · Controller module for PI control action

Details on further controller modules for P, PI, PD and PID control as well as on additional modules for special control tasks can be found in Data Sheet T 7040 EN.

Ordering text

Controller Module Type 3434- ...
Output 0.2 to 1 bar or 3 to 15 psi



Fig. 1 · Type 3434-1 P Controller Module



Fig. 2 · Type 3434-2 PI Controller Module

Principle of operation

Type 3434-2 PI Controller Module

The controlled variable x and the reference variable w are routed to the diaphragm chambers (11) and (12) over the switchover plate A as gauge pressures between 0.2 and 1 bar or 3 to 15 psi. When x exceeds w , the force switch (21) is lowered and opens the plug. The supply air flows into diaphragm chamber R2 and the output pressure y_A increases. Over the T_n restrictor (18), the output pressure is routed into the volume of the 1:1 booster (22), whose output pressure is fed back into the diaphragm chamber. The pressures acting in the diaphragm chambers R1 and R2 are balanced. The position of the force switch changes until the controller output pressure assumes a value assigned to the controlled variable x and the adjusted proportional-action coefficient K_p , i.e. until the system deviation has been evened out.

The proportional-action coefficient K_p is adjusted on the restrictor (14), while the reset time T_n is adjusted on the restrictor (18). The module is calibrated using the zero adjustment screw.

The operating direction, i.e. the output pressure increases or decreases when the controlled variable increases, is selected using switchover plate A.

Type 3434-1 P Controller Module

Design and principle of operation largely correspond to the Type 3434-2 PI Controller Module. However, the feedback element with T_n restrictor is replaced by a spring for fixed operating point adjustment at 0.6 bar.

- | | |
|--|--|
| R1 Diaphragm chamber | 14 K_p restrictor |
| R2 Diaphragm chamber | 18 T_n restrictor |
| A Switchover plate for operating direction | 20 Diaphragm |
| 11 Diaphragm chamber | 21 Force switch with plug |
| 12 Diaphragm chamber | 22 1:1 booster; |
| 13 Zero adjustment screw | fixed operating point adjustment in P controller |

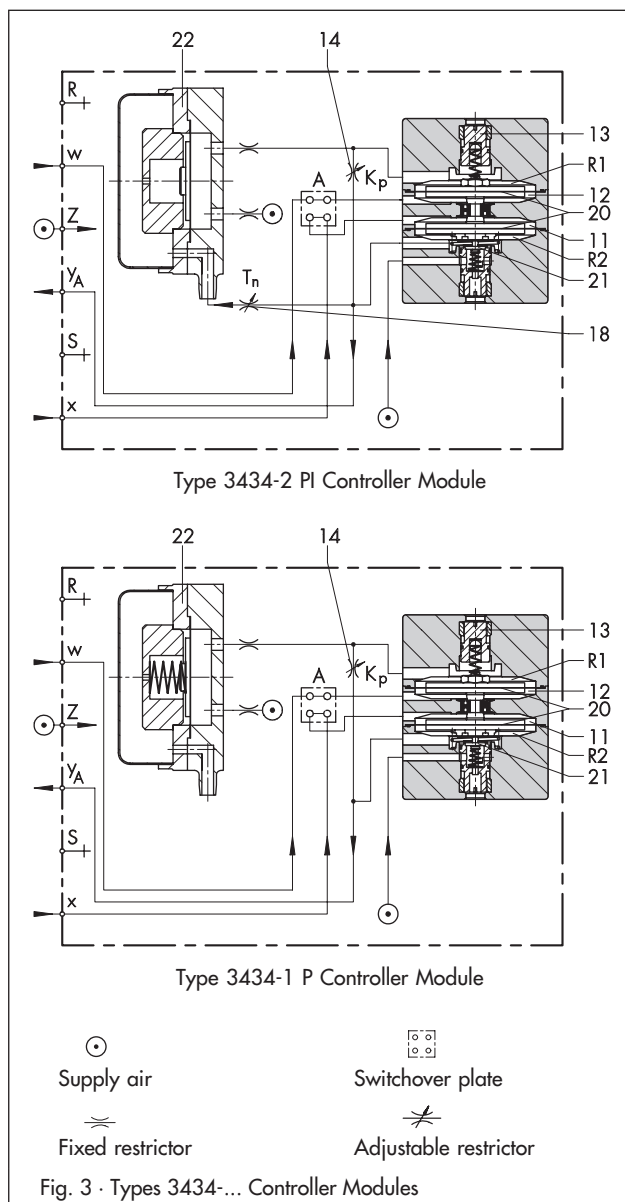

Table 1 · Technical data · All pressures in bar (gauge)

Controller module	Type 3434-1	Type 3434-2
Controller function	P	PI
Control parameters	Proportional-action coefficient $K_p = 1$ to 20 Operating point fixed at 0.6 bar (9 psi)	
Input	0.2 to 1.0 bar (3 to 15 psi)	
Output Max. air delivery	0.2 to 1.0 bar (3 to 15 psi) · Max. 0.02 to 1.35 bar (0.3 to 19 psi) > 1.5 m ³ /h	
Air supply	1.4 bar (20 psi)	
Steady-state air consumption	< 0.12 m ³ /h	
Alignment offset	< 1 %	
Tracking error	< 1 %	
Sensitivity	< 0.01 %	
Supply air influence at 1.4 ± 0.1 bar supply pressure	< ± 0.1 %	
Temperature influence	< 0.1 %/°C	
Permissible ambient temperature	-20 to +60 °C	
Weight	Approx. 0.7 kg	

Specifications subject to change without notice.



SAMSON AG · MESS- UND REGELTECHNIK
Weismüllerstraße 3 · 60314 Frankfurt am Main · Germany
Phone: +49 69 4009-0 · Fax: +49 69 4009-1507
Internet: <http://www.samson.de>

T 7041 EN