

Pneumatic Compact Controller Type 3421 Manual Control Station Type 3422

Application

Compact controller (front frame 72 x 144 mm) for P, PI, PD and PID control loops · Control loops with control mode changeover or signal limitation · For ratio, cascade, and slave control loops or other control applications

Input and output signals ranging between 0.2 and 1.0 bar (3 and 15 psi) · Supply pressure 1.4 bar (20 psi)



The Type 3421 Compact Controllers consist of a Type 3422 Manual Control Station, a Type 3423 Controller Module and a Type 3424 Additional Module, which is needed only for special control tasks. The controllers meet special process engineering requirements and are user-friendly.

Special features

- Compact controllers with a mounting depth of 320 mm (400 mm installation depth)
- Set point, controlled variable, and system deviation are easy to read off at the 100 mm-long flat scale
- All adjusters, switches, and displays can be operated at the front
- Basic version (circuit 1) for universal applications, with standard equipped selector switch w_{int}/w_{ext}

Equippable with controller modules for P, PI, PD and PID control loops · Modules for ratio control loops · Modules also suitable for P and PI control loops (see T 7521 EN) · Bumpless manual/automatic transfer · Control mode changeover or signal limitation (see T 7524 EN)

Type 3422 Manual Control Station

The plug-in unit that can be pulled out contains plug-on connections to connect a controller module or an additional module. On pulling out a module, the pneumatic plug-on connections are self-sealing. The device without components can perform the task of a control station.

The manual control station is available in various versions (circuit 1, 2 or 9) that are adapted to the control tasks. The versions illustrated on page 3 are assigned to certain control loops. The control station components and the plug-in version are adapted to the control task.

The Type 3422 Manual Control Stations are optionally available with inductive limit switches and/or two red LEDs, or limit switches with integrated LED actuation.

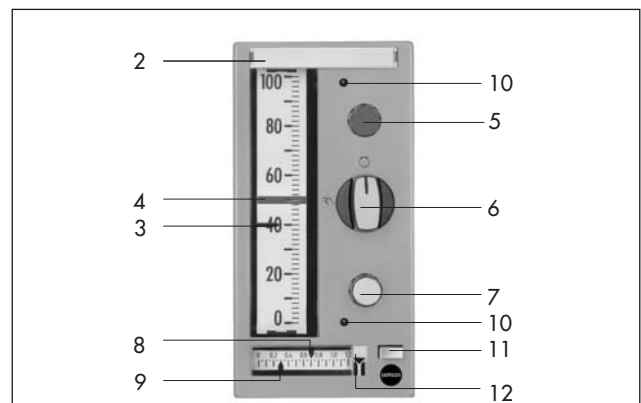

Fig. 1 · Type 3421 Compact Controller, front view

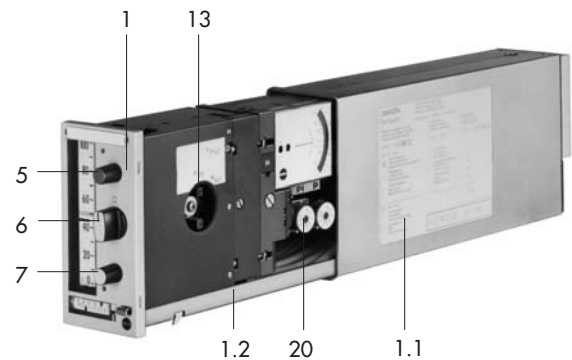

Fig. 2 · Type 3421 with Type 3422 Manual Control Station and Type 3423-5 P/PI Controller Module

- | | |
|-------------------------------|---|
| 1 Manual control station | 8 "Manipulated variable automatic" (y_A) pointer |
| 1.1 Housing | 9 "Manipulated variable manual" (y_H) pointer |
| 1.2 Plug-in unit | 10 LED |
| 2 Identification label | 11 Lock |
| 3 Contr. variable display (x) | 12 Adjustable indicator for valve operating direction |
| 4 Set point pointer (w) | 13 Selector switch w_{int}/w_{ext} |
| 5 Set point adjuster | 20 Controller module |
| 6 Manual/automatic switch | |
| 7 Adjuster for manual mode | |

Fig. 3 shows the front panel of the Type 3422 Manual Control Station, circuit 1. The other versions do not include the set point adjuster (5) or the selector switch w_{int}/w_{ext} (13), additionally the version 9 does not have the set point display (4). Refer to the functional diagrams for further details.

The controlled variable and set point pointers have metal bellows measuring elements. The controlled variable measuring element can optionally be equipped with two adjustable inductive limit switches. In versions with limit switches with integrated LED actuation, the top LED (11) indicates when the maximum limit is exceeded and the bottom LED when the minimum limit is reached.

The manual control station (Fig. 4) consists of the housing (1.1), plug-in unit (1.2) and a flexible hose harness (1.3) which connects the plug-in unit to the connecting plate (1.4).

The manual control station (circuits 1 and 2) can be equipped with the controller modules or additional modules shown in Fig. 4. The version for circuit 9 is designed for fitting the Type 3423-7 Ratio Module.

The installation of limit switches are suitable for use in potentially explosive atmospheres.

The LEDs must not be used in hazardous areas.

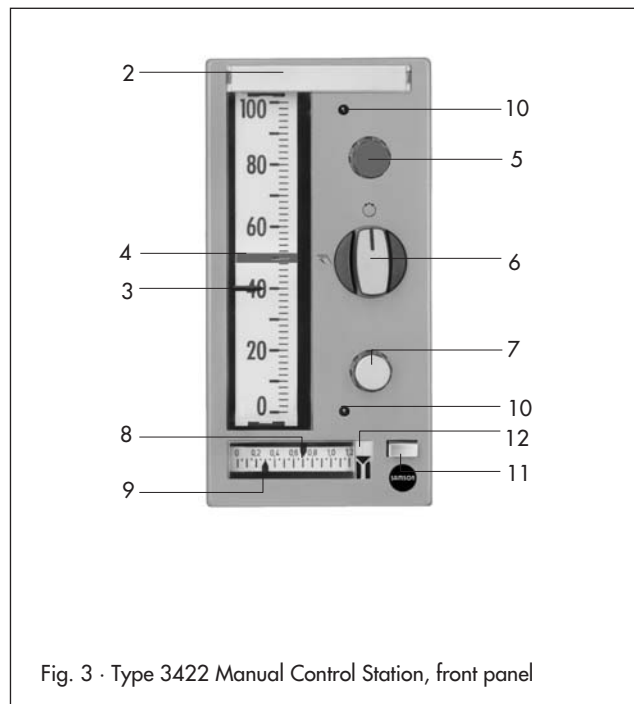
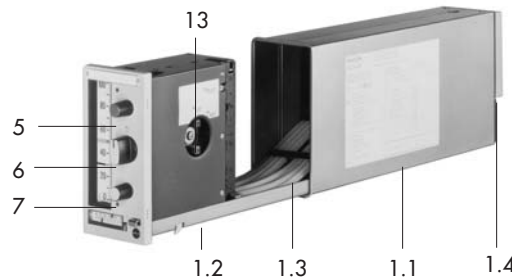

Fig. 3 · Type 3422 Manual Control Station, front panel

Type 3422 Manual Control Station



Shelf design with Type 3426 in multiple units and Type 3428 plug-in also available on request.

Equippable with **controller module**:

- Type 3423-1 (P controller)
- Type 3423-2 (PI controller)
- Type 3423-3 (PID controller)
- Type 3423-4 (PD controller)
- Type 3423-5 (P/PI controller)
- Type 3423-7 (relay module)
- Type 3423-9 (P controller with set point dependent operating point)

With **additional module**:

- Type 3424-4 (bumpless transfer)
- Type 3424-5 (control mode changeover)
- Type 3424-6 (signal limiter)



- 1.1 Housing
- 1.2 Plug-in unit
- 1.3 Hose harness
- 1.4 Connecting plate
- 2 Identification label
- 3 Controlled variable display (x)
- 4 Set point pointer (w)
- 5 Set point adjuster
- 6 Manual/automatic switch
- 7 Adjuster for manual mode
- 8 "Manipulated variable automatic" (Y_A) display
- 9 "Manipulated variable manual" (Y_H) display
- 10 LED
- 11 Lock
- 12 Adjustable display for valve operating direction OPEN or CLOSED with 100 % supply pressure
- 13 Selector switch w_{int}/w_{ext}
- 20 Controller module
- 30 Additional module

Fig. 4 · Type 3422 Manual Control Station, version with circuit 1

Type 3421 Compact Controller	Type 3422 Manual Control Station · Circuit/application								
	<p>Type 3422, circuit 1 with Type 3423-1 to -5 or Type 3423-9 Controller Module and Type 3424-4/-5/-6 Additional Module. For fixed set point control and slave control (also with electric input, bumpless manual/automatic transfer, control mode changeover or signal limitation). In the case of cascade control or other control loops: Master controller to circuit 2 - slave controller to circuit 9 and to controllers without manual control unit ¹⁾.</p>								
	<p>Type 3422, circuit 2 with Type 3423-1 to -5 or Type 3423-9 Controller Module and Type 3424-4/-6 Additional Module. In the case of cascade control or other control loops: Master controller to circuit 1 or 9 - also with bumpless manual/automatic transfer or signal limitation.</p>								
	<p>Type 3422, circuit 9 With Type 3423-7 Controller Module (ratio relay V) and, if needed, Type 3424-1/-2 or -6 Additional Module. In the case of ratio controls: Master controller to circuit 1 or 2 (also with electrical input or signal limitation). The ratio module in the master controller calculates the target ratio for the slave controller.</p> <p>¹⁾ Separate Type 3425 Controller for control room or field installation, see T 7512 EN</p>								
<p>Symbols for the schematic diagrams</p> <table border="0"> <tr> <td> Pneumatic connection</td> <td> Supply air</td> <td> Pneumatic adjuster</td> <td> Manual/automatic switch</td> </tr> <tr> <td> Plug-on connection</td> <td> Venting</td> <td> Blind connection</td> <td></td> </tr> </table>		Pneumatic connection	Supply air	Pneumatic adjuster	Manual/automatic switch	Plug-on connection	Venting	Blind connection	
Pneumatic connection	Supply air	Pneumatic adjuster	Manual/automatic switch						
Plug-on connection	Venting	Blind connection							

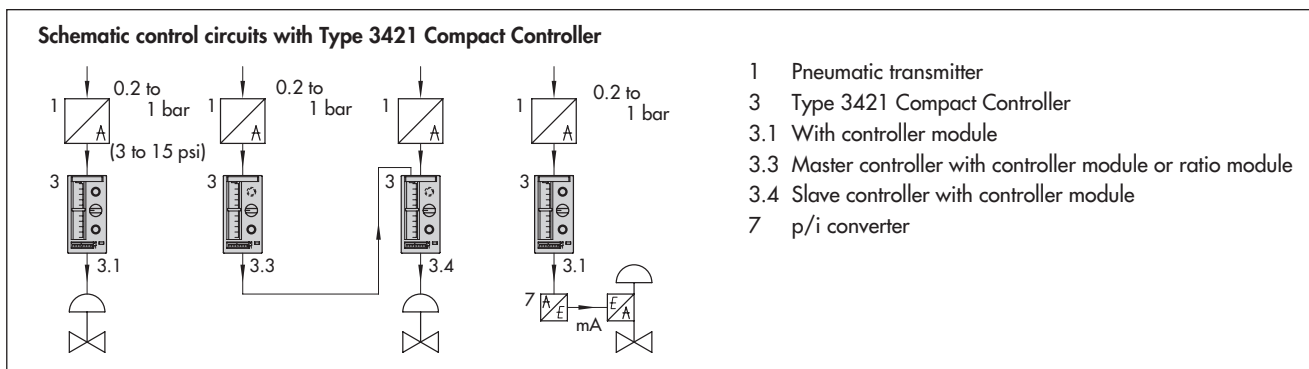

Ordering text

Compact Controller Type 3421, circuit 1 / 2 / 9,
for 0.2 to 1 bar / 3 to 15 psi

With P/PI/PI with feedback limitation/PID/PID with feedback
limitation/PD/P/PI controller module/ratio relay

On option, special version $K_p = 0.4$ to 40

On option, Type 3424-4/3424-5/3424-6 Additional Module
and/or electrical equipment ¹⁾

Manual Control Station Type 3422, circuit 1 / 2 / 9,
for 0.2 to 1 bar/3 to 15 psi, on option, electrical equipment ¹⁾

¹⁾ Electrical equipment: Limit switch and/or LEDs/Limit switch with LED ·
Connections: Faston connector/terminals

Table 1 · Technical data · Type 3422 Manual Control Station · Type 3421 Compact Controller

Type 3422 Manual Control Station · Type 3421 Compact Controller									
Circuit	1 and 2							9	
Set point/controlled variable display	Measuring range 0 to 1.2 bar (3 to 15 psi) · Accuracy class 1 (synchronism: 0.6) Scale: 0 to 100 %, linear (square root on reverse side), length 100 mm								
Manipulated variable display	Measuring range 0 to 1.2 bar (0 to 18 psi) Accuracy class 2.5 · Scale: 0 to 1.2 bar (0 to 18 psi), length 36 mm								
Adjuster	Output	0.2 to 1 bar (3 to 15 psi) · Max. 0.02 to 1.35 bar max. air delivery: >1.5 m _n ³ /h, air consumption depending on adjuster: 0.1 m _n ³ /h							
Limit switches	Two proximity switches SJ3,5-N-Y acc. to DIN EN 60947-5-6, Ex II 2G EEx ia IIC T6								
Limit signal indication	Inductive limit switch with LED actuation								
Equippable with:									
Controller module	Type	3423-1	3423-2 1)	3423-3 1)	3423-4	3423-5	3423-9	3423-7	
	Controller function	P	P	PID	PD	P/PI	P 2)		
	Control parameter	Proportional-action coefficient $K_p = 0.2$ to 20 or 0.4 bis 40 Reset time $T_n = 0.03$ to 50 Min. Rate time $T_v = 0.01$ to 10 Min. Rate gain of $x \approx 10$							Ratio module, mechanically adjustable $V = 0.2$ to 20
	Input · Output	0.2 to 1 bar (3 to 15 psi) · Output max. 0.02 to 1.35 bar							
Additional Module									
Type 3424-4	Bumpless manual/automatic transfer								
Type 3424-5	Control mode changeover, output: Switching pressure approx. 1.4 bar (only for Type 3423-2/-3)								
Type 3424-6	Signal limiter, limitation adjustable								
Supply air	1.4 bar (20 psi) · Air consumption depending on unit: < 0.15 m _n ³ /h								
Perm. ambient temperature	-20 °C to +60 °C								
Weight	Manual control station (without components): Approx. 2.5 kg Type 3421 with controller module: Approx. 3.2 kg Type 3421 Controller with controller module or additional module: Approx. 3.6 kg								

1) Optionally also PD/PID controller function · 2) With set point dependent operating point

Installation and connections

The controller is fixed in the control panel over two rails.
Air connections: Tapped holes 1/8 NPT in the connecting plate.
Electrical connection only in the version with limit switches, LEDs or limit switches with integrated LED actuation (see Fig. 5).

Switching amplifiers must be connected in the output circuit for operating inductive limit switches without LED actuation.

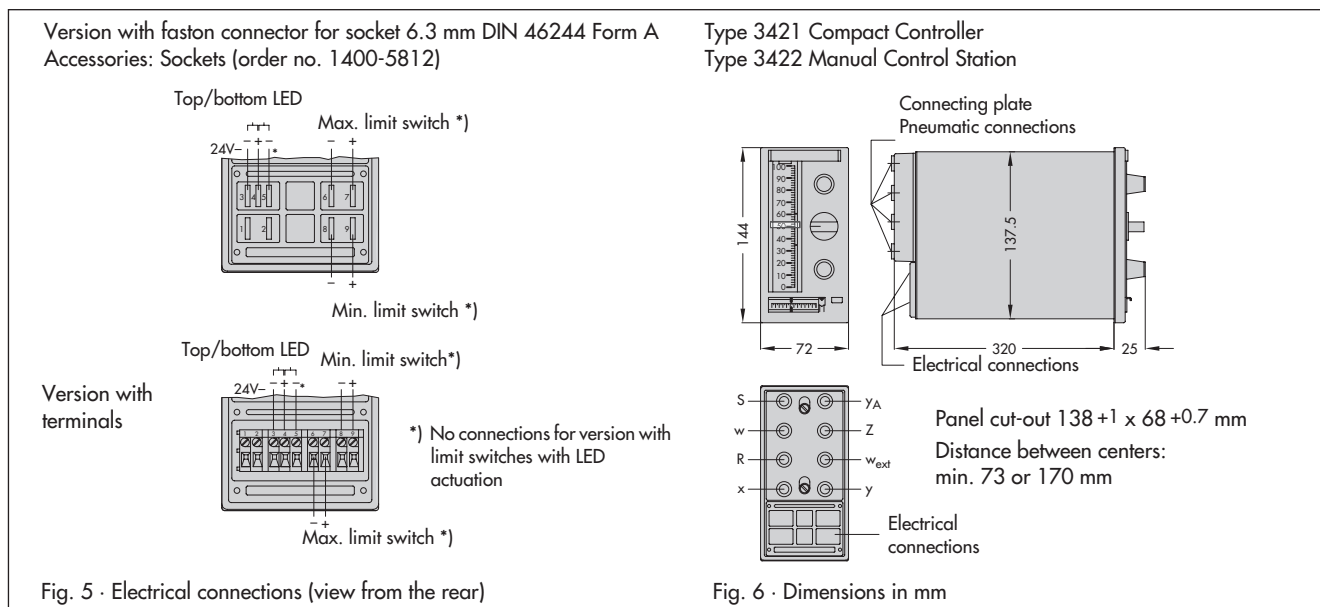

Specifications subject to change without notice.



SAMSON AG · MESS- UND REGELTECHNIK
Weismüllerstraße 3 · 60314 Frankfurt am Main · Germany
Phone: +49 69 4009-0 · Fax: +49 69 4009-1507
Internet: <http://www.samson.de>

T 7506 EN