

Pneumatic Controller Type 3425 Control Room and Field Housing Type 3426

Application

Controllers with manual control unit in control panels or controllers for control room or field installation for P, PI, PD and PID control loops · For control loops with control mode changeover or signal limitation · For ratio, cascade or slave control loops or other control loops

The standardized controllers are designed for input and output signals from 0.2 to 1.0 bar (3 to 15 psi) and for a supply pressure of 1.4 bar (20 psi). The Type 3425 Controllers are usually connected to Type 3427 Manual Control Unit (see T 7511 EN). They can also be combined with Type 3422 Manual Control Station (see T 7506 EN).

The Type 3425 Controller consists of a Type 3426 Control Room or Field Housing, a Type 3423 Controller Module and a Type 3424 Additional Module, which is only needed for special control tasks.

Special features

- Equippable with controller module for P, PI, PID or PD control loops, modules for ratio control loops, modules that are also suitable for both P and PI control loops (see T 7521 EN)
- Equippable with additional modules for bumpless manual/automatic transfers, control mode changeover or signal limitation (see T 7524 EN)

Type 3426 Control Room/Field Housing

Type 3426-2 · Control room housing especially for mounting in control rooms or instrumentation cabinets

Type 3426-3 · Field housing for mounting on controller racks located near to the control unit or control station

The splash-proof housing of Type 3426-3 Housing is suitable for open-air installation.

The Type 3427 Manual Control Units and the Type 3422 Control Stations without components are available in various versions that are adapted to the control tasks (circuit 1, 2 and 9). The schematics on page 3 are assigned to certain control circuits. The manual control unit with components and the controller version is adapted to the control task.



Fig. 1 · Type 3425 Pneumatic Controller with Type 3426-2 Control Room Housing and Type 3423-5 P/PI Controller Module



Fig. 2 · Type 3425 Pneumatic Controller with Type 3426-3 Field Housing and Type 3423-2 PI Controller Module



Fig. 3 · Type 3426-3 Field Housing
equippable with:



- Controller Module:
- Type 3423-1 (P controller)
 - Type 3423-2 (PI controller)
 - Type 3423-3 (PID controller)
 - Type 3423-4 (PD controller)
 - Type 3423-5 (P/PI controller)
 - Type 3423-6 (PD/PID controller)
 - Type 3423-7 (Vm)
 - Type 3423-8 (Vp)
 - Type 3423-9 (P controller with set point dependent operating point)



- Type 3423-1/5 Controller Module and additional module:
- Type 3424-4 (bumpless transfer)
 - Type 3424-5 (control mode changeover)
 - Type 3424-6 (signal limiter)

The Type 3426 Control Room or Field Housing can be equipped with the controller modules and additional modules illustrated in Fig. 3.

The selection depends on operating conditions on site and the properties of the control loop. Fig. 4 illustrates instrumentation with corresponding fixed set point control loops with manual control units in the version with circuit 1. In the arrangement acc. to Fig. 4, the controller (2) enclosed in the Type 3426-2 or Type 3426-3 Housing is located in the control room or near the control panel. The signal delay of the measured signal x and that of the control signal y depends on the transmission distance between control room and point of installation.

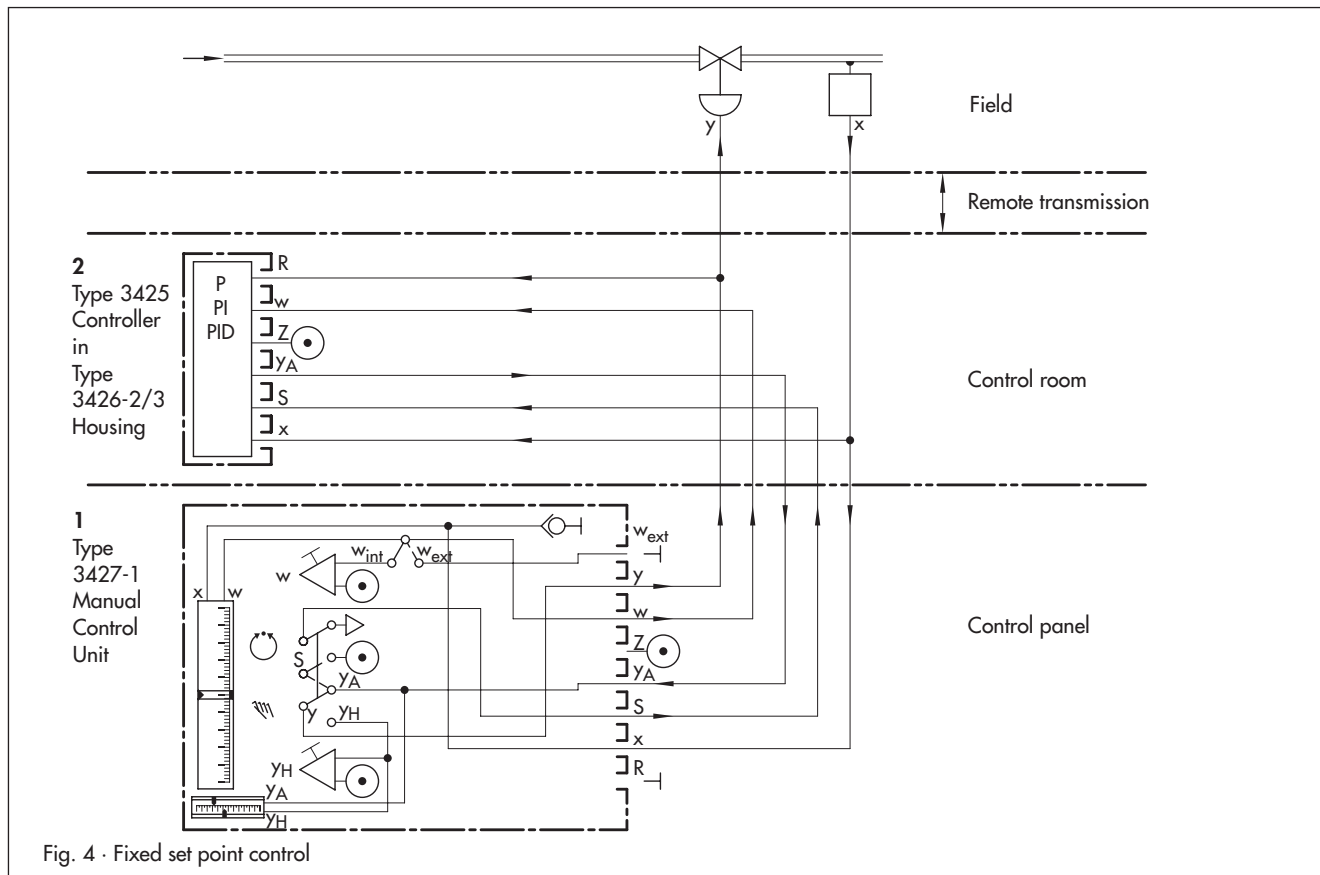
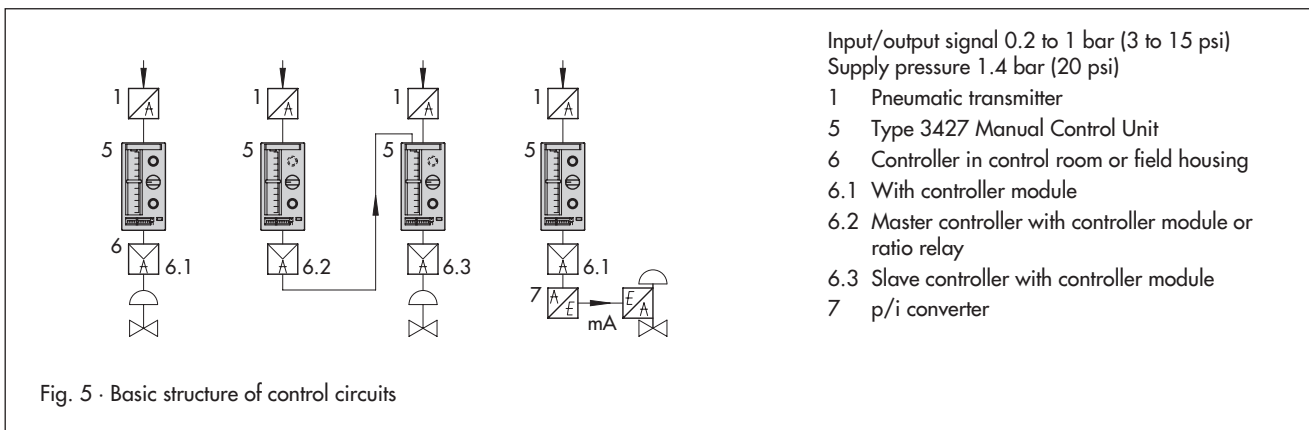

Fig. 4 · Fixed set point control

Type 3427 Manual Control Unit Type 3425 Controller	Circuit/application								
	<p>Circuit 1 · Type 3427-1 and Type 3425 Controller with Type 3423-1/6 and 9 Controller Modules and Type 3424-4/5/6 Additional Modules or with Type 3423-7 Ratio Module ¹⁾.</p> <p>For fixed set point control loops and slave control loops (also with bumpless manual/automatic transfer, control mode changeover and signal limitation).</p> <p>For cascade control loops and other control circuits: Master controller to circuit 2 - slave controller to circuit 9 and to controllers without manual control units ²⁾.</p>								
	<p>Circuit 2 · Type 3427-2 and Type 3425 Controller with Type 3423-1/6 and 9 Controller Modules and Type 3424-4/6 Additional Module or with Type 3423-7 Ratio Module ¹⁾.</p> <p>For cascade control loops and other control circuits: Slave controller to circuit 1 or 9 (also with bumpless manual/automatic transfer or signal limitation).</p>								
	<p>Circuit 9 · Type 3427-9 and Type 3425 Controller with Type 3423-7 Ratio Module (Ratio Relay V) and Type 3424-6 Additional Module.</p> <p>For ratio control loops: Master controller to circuit 1 or 2 (also with signal limitation).</p> <p>The ratio module in the master controller calculates the target ratio for the slave controller.</p>								
<p>*) The line between the ports "S" does not exist in P controllers, in the ratio module and, if applicable, in arithmetic circuits.</p>	<p>1) Type 3424-7 can also be combined with Type 3424-6</p> <p>2) The controllers can also be used without the manual control units in the example.</p>								
<p>Symbols for the schematic diagrams:</p> <table border="0"> <tr> <td> Pneumatic connection</td> <td> Supply air</td> <td> Pneumatic adjuster</td> <td> Manual/automatic switch</td> </tr> <tr> <td> Push-on connection</td> <td> Venting</td> <td> Blind connection</td> <td></td> </tr> </table>		Pneumatic connection	Supply air	Pneumatic adjuster	Manual/automatic switch	Push-on connection	Venting	Blind connection	
Pneumatic connection	Supply air	Pneumatic adjuster	Manual/automatic switch						
Push-on connection	Venting	Blind connection							



Ordering text

Type 3425 Pneumatic Controller for 0.2 to 1 bar (3 to 15 psi) with P/PI/PI with feedback limitation/PID/PID with feedback limitation/PD, P, PI controller module/ratio relay/ratio module

On option, special $K_p = 0.4$ to 40

With Type 3426-2 Control Room Housing/Type 3426-3 Field Housing

