

Application

Controller modules for Type 3421 Compact Controllers and Type 3425 Control Room and Field Controllers for P, PI, PD and PID control equipment and ratio control loops.

The Type 3423 Controller Modules are designed for input and output signals in the ranges from 0.2 to 1.0 bar (3 to 15 psi) and for a supply air pressure of 1.4 bar (20 psi). For special control applications, these modules can be combined with an additional module, for e.g. bumpless manual/automatic transfer, control mode changeover or signal limitation (see Data Sheet T 7524 EN).

The controller modules are plug-in units, designed for installation in Type 3421 Compact Controllers (see Data Sheet T 7506 EN) or Type 3425 Control Room or Field Controllers (see Data Sheet T 7512 EN). The controller modules are plugged into the self-sealing connections of the respective controllers. The controller modules are fastened by a screw.

Versions

The controller modules are equipped with a comparator which operates according to the motion-balance principle using four spring-loaded metal bellows arranged in a square. The proportional action coefficient K_p (gain) can be set mechanically. Standard versions are designed for $K_p = 0.2$ to 20, special versions for $K_p = 0.4$ to 40.

Type 3423-1 (Fig. 1) · Controller module for P control, with integrated operating point adjuster.

Type 3423-2 (Fig. 2) · Controller module for PI control. Optionally with feedback limiter.

Type 3423-3 (Fig. 3) · Controller module for PID control. Optionally with feedback limiter.

Type 3423-4 · Controller module for PD control.

Type 3423-5 (Fig. 4) · Controller module for P and PI control. The module can be used as either PI or P controller with integrated operating point adjuster. Modules for PD and PID control also available on request (Type 3423-6).

Type 3423-7 (Fig. 5) · Ratio module designed for ratio control of two process variables. The ratio of output and input is mechanically adjustable from 0.2 to 20.

Type 3423-9 · P controller module with set point dependent operating point.

The controller modules are applicable for special control tasks (e.g. single and multi-stage cascade control, feedforwarding of disturbance and auxiliary variables).



Fig. 1 · Type 3423-1 P Controller Module



Fig. 2 · Type 3423-2 PI Controller Module



Fig. 3 · Type 3423-3 PID Controller Module



Fig. 4 · Type 3423-5 P/PI Controller Module



Fig. 5 · Type 3423-7 Ratio Module

Principle of operation

Type 3423-2, PI Controller Module (Figs. 6 and 7)

The controlled variable x and the reference variable w - both pneumatic signals between 0.2 and 1 bar (3 and 15 psi) - are transferred via turnboard A to the metal bellows (5) and (7). When x exceeds w , the actual value bellows (7) tilts the cross spring pivoted swashplate (1) over the pin (2) towards the set point bellows (5), causing the nozzle (9) to move closer to the flapper (10). As a result, the pressure in the nozzle and the output pressure y_A of the booster (16) increase. The pressure y_A is fed back immediately via turnboard B to the bellows R2 (8) and, with a certain delay, via the external connection R and the T_n restriction (18) to the bellows R1 (6). The position of the swashplate (1) and the output pressure y_A keep changing until the distance between nozzle and flapper is the same as initially and the output pressure y_A assumes a value corresponding to the controlled variable x and the adjusted proportional-action coefficient K_p (gain), i.e. until system deviation is eliminated.

The proportional-action coefficient (gain) is adjustable by means of screw (14), the reset time T_n at the restriction (18). The starting point of the controller can be corrected using the zero adjustment screw (13).

On delivery, the turnboard B is set to y_A , i.e. the output pressure y_A is directly fed back to bellows R2. To bellows R1, however, it is fed via connection R. With this circuit arrangement, the controller provides normal air delivery and output pressure damping. Therefore, no additional volume must be connected as was previously necessary, even under exceptional operating conditions - e.g. in case of a particularly short transmission path of the output pressure and a small connected volume. In case of long transmission paths of the output pressure to the final control element, a large connected air volume, and fast controlled systems, however, it is useful to turnboard B over to R. In this arrangement, the output pressure y_A is fed back via connection R to the bellows R1 and R2. As a result, the controller features a favourable air delivery characteristic.

Fig. 7 shows the functional diagram of the PI controller module illustrated in Fig. 6. The operating direction - direct or reverse action - is selectable by the position of the turnboard A for an increasing controlled variable.

If, for example, for manual operation of the valve, a switching pressure is applied to connection S, the T_n start-up relay (19) switches over. It opens the bypass of the T_n restriction (18) and causes the pressure to be fed back to the bellows R1 and R2.

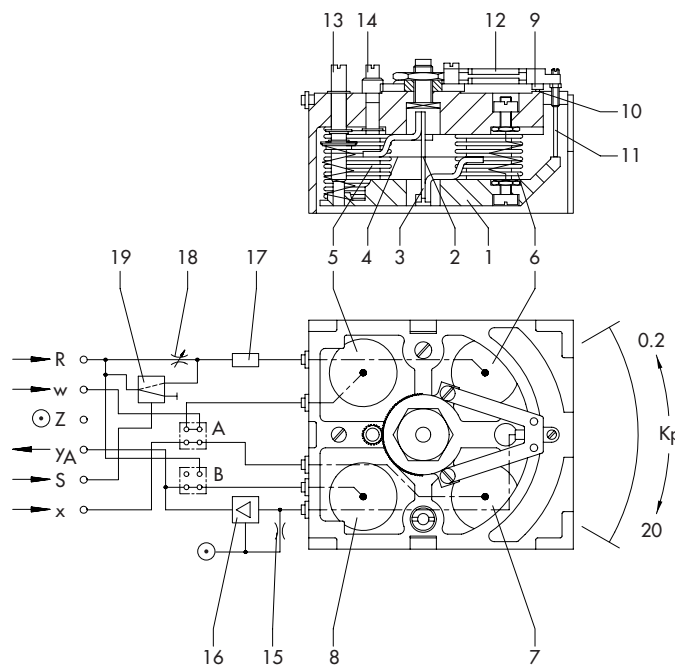

Fig. 6 · Type 3423-2 PI Module

Legend to Figs. 6 to 15

w	Reference variable (set point)	1	Swashplate	8	Feedback bellows R2	15	Supply restriction
x	Controlled variable	2	Pivot	9	Nozzle	16	Booster
y_A	Output pressure	3	Pivot pin	10	Flapper	17	Volume
R	Feedback signal to bellows R1	4	Cross spring pivot	11	Pin	18	T_n restriction
S	Switching pressure	5	Set point bellows (w)	12	Spring	19	T_n start-up relay
		6	Feedback bellows R1	13	Zero adjustment screw	A	Turnboard for oper. direction
		7	Actual value bellows (x)	14	K_p (gain) adjuster	B	Turnboard for feedback

Type 3423-1 · P Controller Module (Fig. 8)

This module is largely identical with the Type 3423-2 PI Controller Module. The T_n restriction (18) and start-up relay (19), however, are replaced by an operating point adjuster whose constant output pressure (adjustable between 0.2 and 1 bar) is fed to the bellows R1. The output pressure of the booster (y_A) is passed via the fixed turnboard B to the bellows R2.

Type 3423-3 · PID Controller Module (Fig. 9)

This PID controller module is largely identical to the Type 3423-2 PI Controller Module. This module, however, contains an additional derivative element providing rate action of the input (controlled variable x). Under steady-state conditions, the output signal of the booster D1 is identical with the input signal x. When the input x changes, this change is amplified about 10 times by the booster D1. Amplification decreases to the ratio 1:1 as a function of the rate time adjusted at the T_v restriction. The T_v start-up relay (D2) bypasses the T_v restriction when a pressure is applied to connection S.

Type 3423-4 · PD Controller Module (Fig. 10)

This PD controller module is a P controller with an additional derivative element providing rate action of the input (controlled variable x). When the input signal x changes, this change is amplified about 10 times by the booster D1. The derivative signal decreases acc. to an e-function. It assumes the value of the input signal x when the adjusted rate time, set at the T_v restriction, has elapsed. In case of malfunction, the P controller responds faster to the error in the controlled system than the PD controller. This is advantageous in controlled systems with delay or dead times. When a pressure is applied to input S, the T_v start-up relay (D2) bypasses the T_v restriction.

Type 3423-5 · P/PI Controller Module (Fig. 11)

The P/PI controller module can be used either as P controller with operating point adjuster or PI controller. It is suitable for more than 80 % of all control applications which simplifies process engineering tasks and inventory management. Furthermore, the use of this module is appropriate when the dynamic performance of the controlled system is unknown. This module is designed in the same way as the PI and P controller modules. By means of the P/PI selector switch, either the feedback pressure (PI controller) or the output pressure of the operating point adjuster (P controller) can be returned to bellows R1.

Type 3423-9 · P Controller Module with set point dependent operating point (Fig. 12).

P controller module as Type 3423-1, but with set point dependent operating point. The operating point changes proportionally to the set point w.

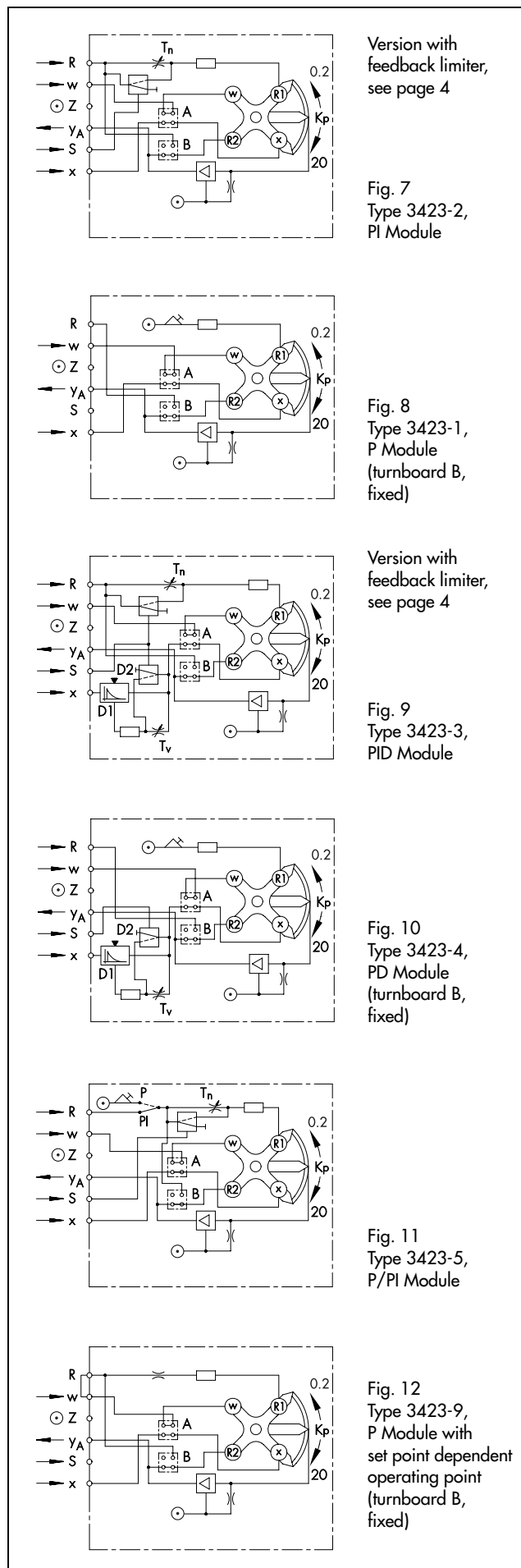

Version with feedback limiter, see page 4

Fig. 7
Type 3423-2,
PI Module

Fig. 8
Type 3423-1,
P Module
(turnboard B,
fixed)

Version with feedback limiter, see page 4

Fig. 9
Type 3423-3,
PID Module

Fig. 10
Type 3423-4,
PD Module
(turnboard B,
fixed)

Fig. 11
Type 3423-5,
P/PI Module

Fig. 12
Type 3423-9,
P Module with
set point dependent
operating point
(turnboard B,
fixed)

Symbols used in the block diagrams			
	Supply air		Booster
	Venting		Turnboard
	Restriction		Adjuster
	Adjustable restriction		Start-up relay

Feedback limiter for Types 3423-2/-3 (Figs 13 and 14)

The Type 3423-2/-3 PI or PID Controller Modules can be equipped with a max. feedback limiter. When the adjusted limit value is exceeded, the limiter limits the feedback signal and supplies a constant pressure proportional to this max. value. This pressure changes the dynamic response of the controller module, since the T_n element becomes ineffective. In this case, the device operates as P or PD controller with an operating point corresponding to the adjusted limit value. Such a limitation is suitable for, e.g. non-linear controlled systems and process-oriented control solutions.

Type 3423-7 · Ratio Relay (Fig. 15)

This device is designed as the Type 3423-1 P Controller Module. The constant output pressure of the operating point adjuster, however, is fed to the bellows R1 and w. The output pressure a is proportional to the input pressure e ($a = e \cdot K_p$). In ratio control applications, this pressure is the reference variable for the slave controller. The ratio $V = a/e$ is adjusted in the same way as the proportional-action coefficient K_p (gain) for P controllers.

Symbols for block diagrams, see page 3.

Ordering text

Type 3423-. Controller Modules for P /PI /PID /PD /P/PI control/Ratio Module

Output 0.2 to 1 bar/3 to 15 psi

On option, special version with feedback limiter/with set point dependent operating point/ K_p (gain) = 0.4 to 40.

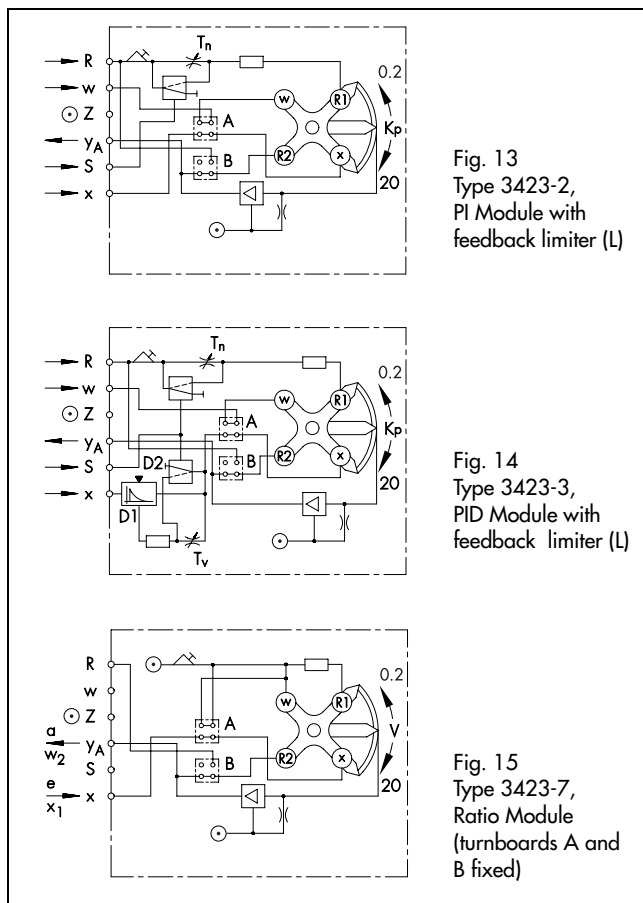

Fig. 13
Type 3423-2,
PI Module with
feedback limiter (L)

Fig. 14
Type 3423-3,
PID Module with
feedback limiter (L)

Fig. 15
Type 3423-7,
Ratio Module
(turnboards A and
B fixed)

Technical data · All pressures in bar (gauge)

Controller module	Type	3423-1	3423-2	3423-3	3423-4	3423-5	3423-9	3423-7
Control mode		P	PI	PID	PD	P/PI	P ¹⁾	Ratio module
Control parameters		Proport.-action coeff. $K_p = 0.2$ to 20 or 0.4 to 40 Reset time $T_n = 0.03$ to 50 min Rate time $T_v = 0.01$ to 10 min Rate gain of x: ≈ 10						Ratio $V = a/e$ $V = 0.2$ to 20
		Operating point adjustment: 0.2 to 1.0 bar (3 to 15 psi)						
Input		0.2 to 1.0 bar (3 to 15 psi)						
Output		0.2 to 1.0 bar (3 to 15 psi) – max. 0.02 to 1.35 bar (0.3 to 19 psi) Max. air delivery: $> 1.5 \text{ m}^3/\text{h}$ Air delivery: when board B is set to "YA": approx. $1 \text{ m}^3/\text{h}$ per % of system deviation when board B is set to "R": approx. $3 \text{ m}^3/\text{h}$ per % system deviation						
Supply		Supply air 1.4 bar (20 psi)						
Air consumption in steady-state condition	m^3/h	< 0.1	< 0.05	< 0.13	< 0.1	< 0.05	< 0.05	< 0.1
Alignment offset		< 0.5 %						Hysteresis < 0.4 % (1 % for $V > 2$)
Tracking error		< 0.5 %						Deviation from characteristic < 1 %
Sensitivity		< 0.01 %						
Derivative element		Deviation from actual value x: < 1 %						
Supply air effect at 1.4 ± 0.1 bar		< ± 0.1 % (D element additionally: < ± 0.2 %)						< ± 1 % (< ± 0.4 % for $V < 2$)
Temperature influence/°C		< 0.01 % (D element additionally: < 0.01 %)						< 0.05 % (< 0.02 % for $V = 0.5$ to 2)
Perm. ambient temperature		-20 to +60 °C						

¹⁾ With set point-dependent operating point

Specifications subject to change without notice.

