

Pneumatic Transmitter for Temperature



Type 3812-1 · With fixed sensor or sensor with capillary tube

Application

Temperature transmitter for use in pneumatic control systems with temperatures from -40 to $+300$ °C

Instruments for measuring temperatures and converting the measured value into a standardized pneumatic signal from 0.2 to 1.0 bar or 3 to 15 psi · Suitable for measuring liquids, gases and vapors

Special features

- Wide variety of applications as the nitrogen (N_2)-filled bulb of the sensor can be used for various media
- Measuring span of 50, 100 or 200 °C
- The lower range value can be adjusted within wide limits
- Sensor made of stainless steel 1.4571 or 1.4404

Versions

Type 3812-1 · Pneumatic transmitter for temperature with bulb or spiral sensor · Measuring span 50, 100 or 200 °C · Measuring limits -40 to $+300$ °C · Measuring range -20 to $+30$ °C, 0 to $+50$ °C, 0 to $+100$ °C, $+50$ to $+150$ °C, 0 to $+200$ °C

Version with fixed temperature sensor (Fig. 1) or with temperature sensor connected to the measuring system by a capillary tube (Fig. 2)

Options

Air temperature sensor (outside diameter 20 mm) or temperature sensor for installation in T-unions acc. to DIN 11857 (for milk and other food and beverages)

Special versions

- Connection pipe with protective metal hose
- G 1/8 supply air connection instead of 1/8 NPT
- Special measuring ranges

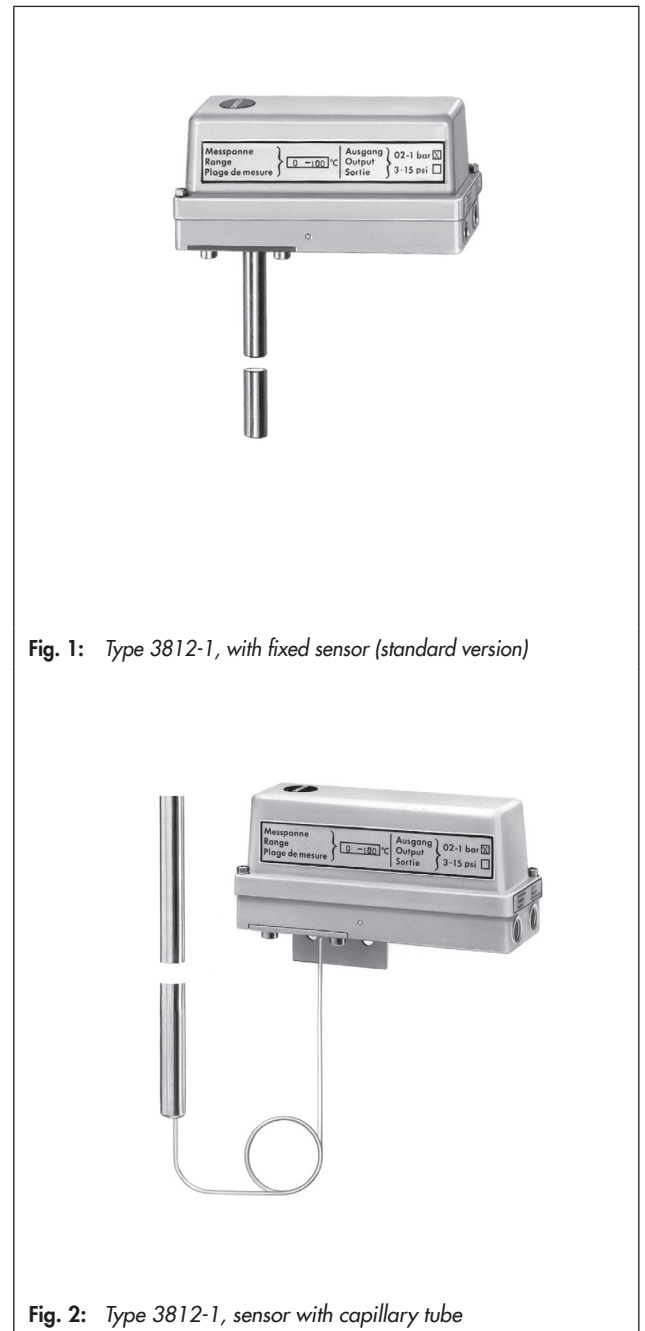

Fig. 1: Type 3812-1, with fixed sensor (standard version)

Fig. 2: Type 3812-1, sensor with capillary tube

Principle of operation (Fig. 3)

The temperature of the process medium produces a pressure proportional to the temperature in the gas-filled sensor (1). This pressure acts on the measuring bellows (1.3) creating a force which is measured at the balance beam (3) and converted into a pneumatic signal (p_A).

The supply air p_Z flows through the booster (8) passes on to the restriction (9) and the nozzle (7) and finally hits the flapper (6). An increase in temperature causes the flapper to come closer to the nozzle. As a result, the output pressure p_A supplied to the bellows (5) rises until an equilibrium is reached again, i.e. until the output signal reaches a value proportional to the temperature.

Zero adjustment at the adjustment screw (11).

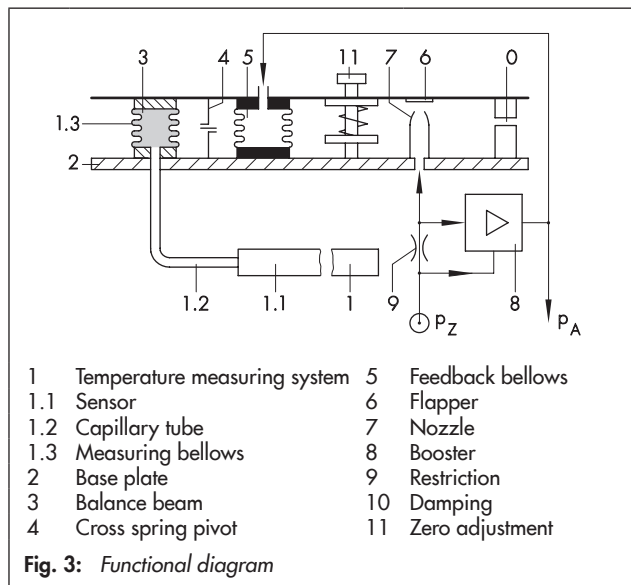

Ordering code

Complete order number as required

Version	Order no. 3812-	0	0	0	...	Ordering text
Sensor type												Type 3812-1 Pneumatic Transmitter (order no. 3812-...)
Bulb sensor		1										
Air sensor		2										
Sensor for food processing (T-union)		3										
Sensor version												
Capillary tube, 3 m			1									
Protected capillary tube, 3 m			2									
Capillary tube, 6 m			3									
Protected capillary tube, 6 m			4									
Bulb sensor, fixed			5									
Span												
50 °C				0	0							
100 °C				1	0							
200 °C				1	1							
Output signal												
0.2 to 1 bar				0	1							
3 to 15 psi				0	2							
Connection												
G 1/8				0	1							
1/8 NPT				0	2							
Measuring range												
-20 to +30 °C											1	
0 to +50 °C											2	
0 to +100 °C											3	
+50 to +150 °C											4	
0 to +200 °C											5	
Span 50 °C, lower range value between -40 and +150 °C											6 ¹⁾	
Span 50 °C, lower range value between -+150 and +250 °C											7 ¹⁾	
Span 100 °C, lower range value between -40 and +200 °C											8 ¹⁾	
Span 200 °C, lower range value between -40 and +100 °C											9 ¹⁾	

¹⁾ Specify the measuring range that you require on ordering. The transmitter will then delivered with this measuring range.

Table 1: Technical data · All pressure stated as gauge pressure p_e in bar

Span	50 °C	100 °C	200 °C
Measuring limits	-40 to +300 °C		
Overload limits	350 °C	350 °C	500 °C
Supply air	Supply air 1.4 ± 0.1 bar (20 ± 1.5 psi)		
Output	0.2 to 1.0 bar (3 to 15 psi)		
Air output capacity	Max. 2 m ³ /h		
Consumption	0.1 m ³ /h in steady-state conditions		
Load characteristic	0.8 m ³ /h, reversing error < 0.3 %		
Deviation from terminal-based linearity	0.6 % with terminal-based conformity		
Hysteresis	< 0.2 %		
Influence	Supply air: < 0.12 %/0.1 bar		
Pressure at the sensor	< 0.4 %/10 bar	< 0.2 %/10 bar	< 0.1 %/10 bar
Ambient temperature	< 0.06 %/K	< 0.03 %/K	
Permissible ambient temperature	-40 to +90 °C		
Capillary tube length	3 m or 6 m		

Table 2: Materials: Material numbers according to DIN EN

Type 3812-1	
Enclosure and cover	Die-cast aluminum AlSi12
Bellows	Bronze
Bellows fixture	Brass
Diaphragms	ECO (epichlorohydrine)
Seals and O-rings	Silicone
Sensor	Stainless steel 1.4571/1.4404
Sensor filling	Inert gas
Capillary tube	Stainless steel 1.4571/1.4404
Clamping flange, screw gland, thermowells	Stainless steel 1.4571/1.4404

Dimensions in mm

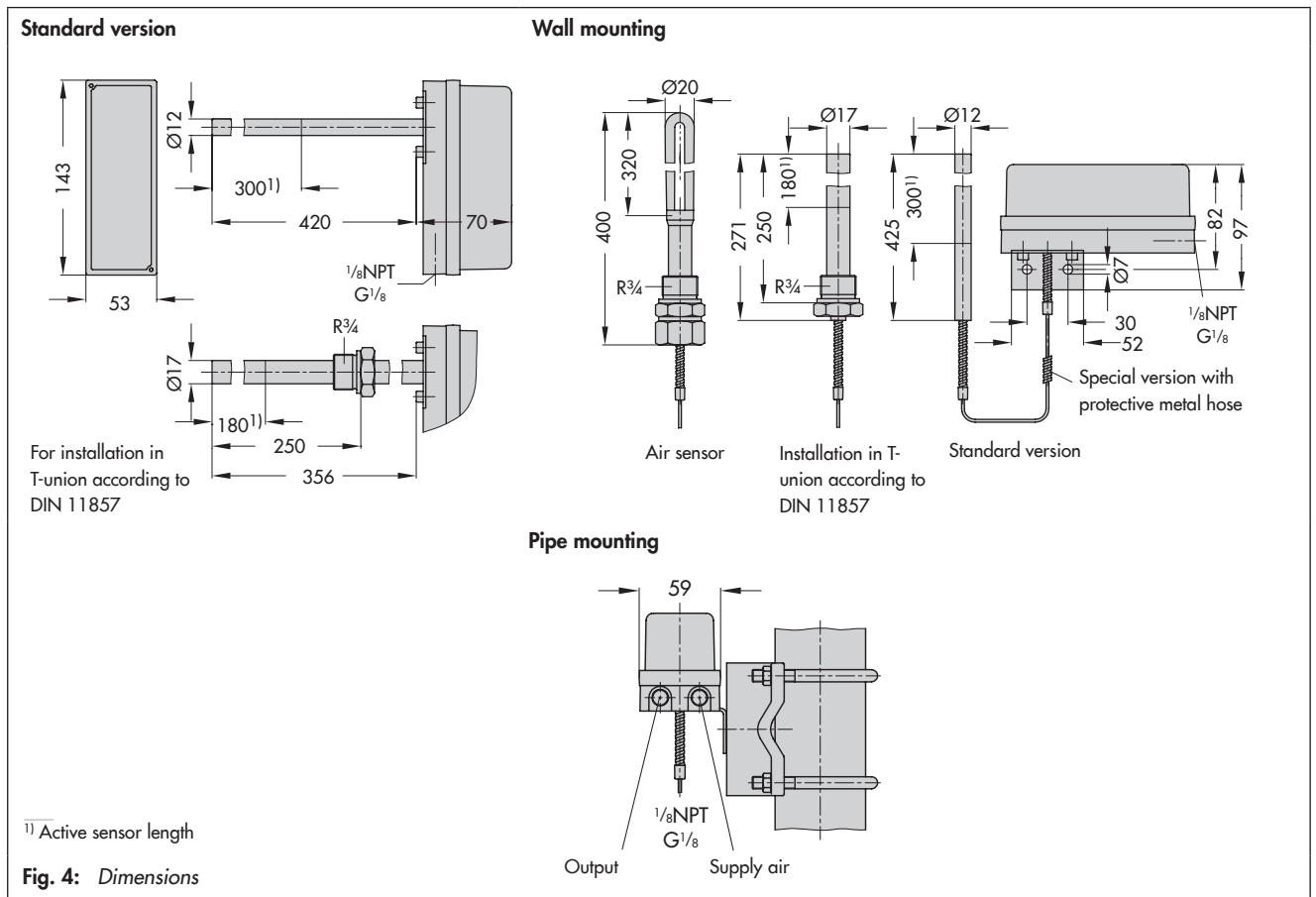

Installation

All the dimensional diagrams show the standard mounting position. Other mounting positions may require the correction of the lower range value.

For versions with capillary tube, the temperature sensor can be mounted in any position. This version comes supplied with a bracket for wall mounting. Pipe mounting requires a special mounting bracket (order no. 1089-0101).

To ensure accurate measurements, the active bulb length of the sensor must be entirely immersed in the fluid to be measured.

Air connections: Two tapped holes 1/8 NPT (optionally, two tapped holes ISO 228 G 1/8).

Accessories

Accessories are not included in the scope of transmitter delivery. They need to be ordered separately. Select accessories required for the operating conditions at the site of installation.

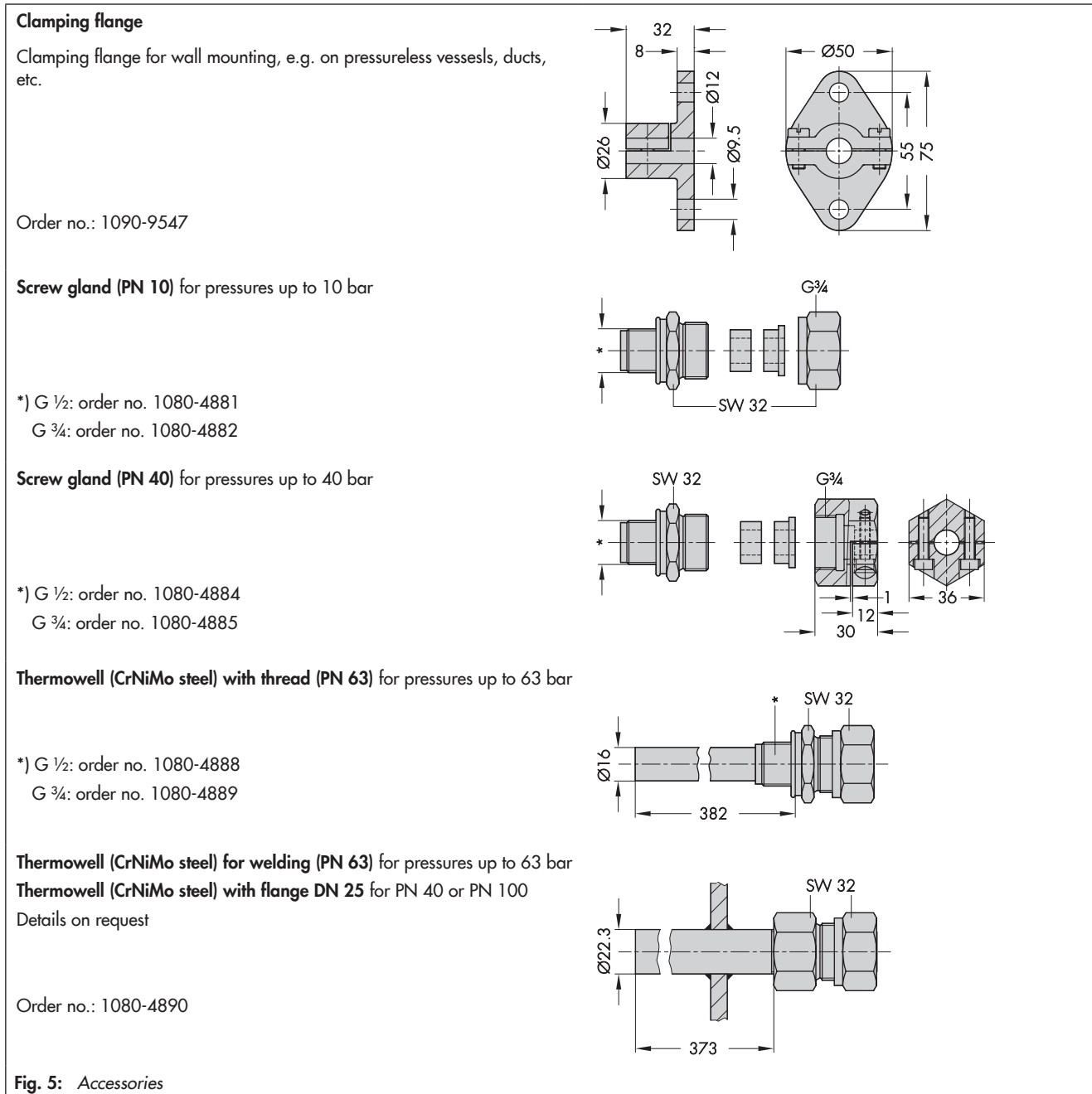

Fig. 5: Accessories

Specifications subject to change without notice

