

Pneumatic Control and Quick-acting Shut-off Valve for liquid fuels and liquefied petroleum gas in the liquid phase

Type 3241-1-Oil and Type 3241-7-Oil

Application

Control valve designed as control and safety shut-off device for combustion plants burning liquid fuels

DN 15 and DN 25 · PN 16 and PN 40 · Up to 350 °C



Control and quick-acting shut-off valve consisting of Type 3241 Globe Valve and Type 3271 Pneumatic Actuator (Type 3241-1 Control Valve) or Type 3277 Pneumatic Actuator (Type 3241-7 Control Valve) for integral positioner attachment as well as a mounted pilot valve (3/2-way solenoid valve) and a strainer (see T 1015 EN).

The safety shut-off valves, typetested according to DIN EN ISO 23553, control the supply of liquid fuels and liquefied petroleum gas (LPG) in the liquid phase. In the event of a fault, the valves shut off the flow.

Valve body with undivided bonnet made of

- Cast steel or cast stainless steel
- Forged steel 1.0460 (C 22.8) or 1.4571

The control valves, designed according to the modular assembly principle, can be equipped with various accessories:

Positioners, solenoid valves and other accessories according to IEC 60534-6 (NAMUR). Refer to Information Sheet T 8350 EN for more details.

Version

Standard version for temperatures up to 220 °C, valve body materials according to Table 2, with soft-seated plug, stem sealed by spring-loaded PTFE V-ring packing, pneumatic actuator with mounted pilot valve and Type 2 NI Strainer.

- **Type 3241-1-Oil** (Fig. 1, top) · Pneumatic control and quick-acting shut-off valve with Type 3271 Actuator (refer to Data Sheet T 8310-1 EN)
- **Type 3241-7-Oil** (Fig. 1, bottom) · Pneumatic control and quick-acting shut-off valve with Type 3277 Actuator (refer to Data Sheet T 8310-1 EN)

Further versions

- **Bellows seal** for temperatures up to 350 °C, backup packing and test connection
- **Control and quick-acting shut-off valve for gases**, DIN/DVGW-tested (refer to T 8020 EN)

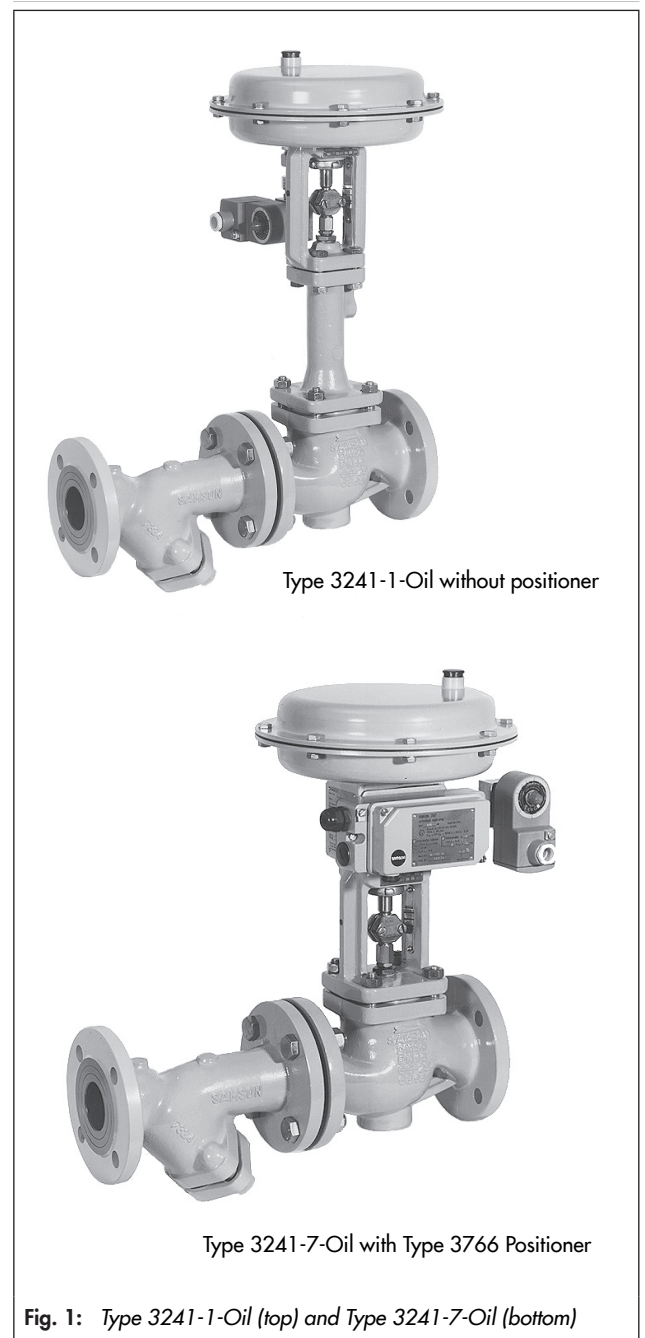

Principle of operation

The process medium flows through the strainer (12) and the valve in the direction indicated by the arrow. In the standard version, the plug stem is sealed by a spring-loaded PTFE V-ring packing. In versions with a bellows seal, the plug stem is sealed by the bellows and an additional back packing. The test connection allows the bellows seal to be monitored for leakage.

The signal pressure p_{st} acts on the pilot valve (11), the coil of which is connected to the safety interlock circuit (switch 14) of the furnace plant. During operation, the coil is energized and the signal pressure p_{st} at port 1 (Fig. 4 and Fig. 5) acts on the diaphragm. In the event of a malfunction or power supply failure, the pilot valve is de-energized and the signal pressure is vented over port 3. The force of the actuator springs closes the control valve in less than one second.

The control valve closes upon failure of the air supply independently from the electrical safety interlock circuit.

DIN register number

The control valves have been typetested by the German Technical Inspectorate (TÜV) and have been assigned DIN CERTCO register numbers.

Installation

The valve may be installed in any position. Make sure that the process medium flows through the valve in the direction indicated by the arrow.

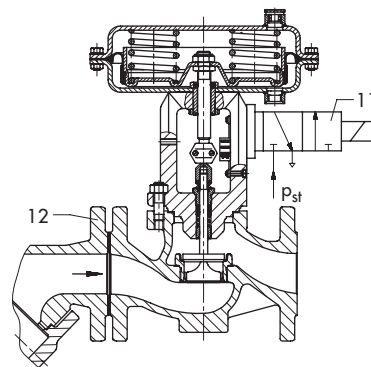

Fig. 2: Type 3241-1-Oil
Standard version with soft-seated plug

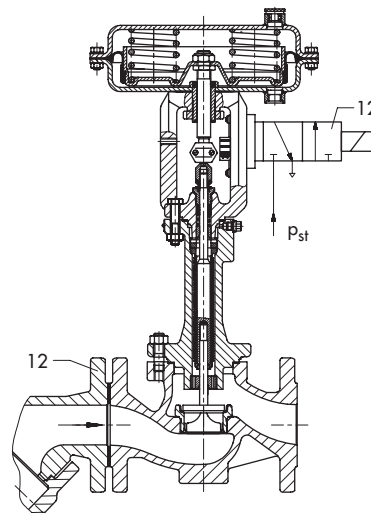

Fig. 3: Type 3241-1-Oil with bellows seal and plug with high-performance metal sealing

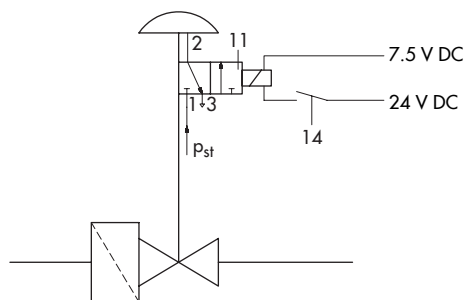

Fig. 4: Functional diagram showing version without positioner

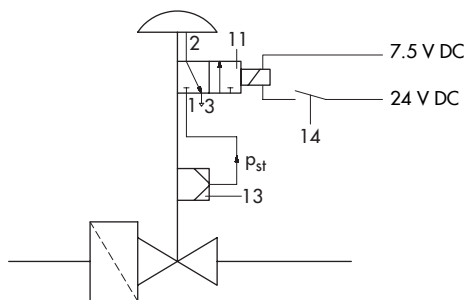

Fig. 5: Functional diagram showing version with positioner

Legend for Fig. 2 to Fig. 5:

- 11 Pilot valve
- 12 Strainer
- 13 Positioner
- 14 Switch for safety interlock circuit

Table 1: Technical data· All pressures in bar (gauge)

DIN register number		On request		
Nominal size	DN	15	25	
K _{v5} coefficient	PN	1.6 · 2.5 · 4.0	1.6 · 2.5 · 4.0	6.3 · 10
Seat diameter	mm	12	12	24
Permissible differential or operating pressure ¹⁾ with soft-seated plug	bar	40	40	40
Permissible differential or operating pressure ¹⁾ with plug with high-performance metal sealing	bar	40	40	26.6
Rated travel	mm	15		
Rangeability		50:1		
Permissible ambient temperature	°C	-15 to 60 °C		
Closing time		< 1 s		
Type 3271 and Type 3277 Actuator				
Effective diaphragm area	cm ²	350		
Bench range	bar	0.4 to 2.0	0.4 to 2.0	0.8 to 2.4
Required supply pressure	bar	2.2	2.2	2.6
Max. supply pressure	bar	6.0	6.0	6.0
Pilot valve²⁾		3/2-way solenoid valve		
Electrical connection		7.5 V	24 V	
Power consumption		20 mW	150 mW	
Type 3963-...76/3756-3206		17	13	
Type of protection		II 2 G EEx ia T6		
Threaded connections		G ¼		
Strainer		Type 2 NI, special version with 0.25 mm mesh size		

¹⁾ Permissible differential and operating pressures are limited by the pressure-temperature diagram. Refer to Information Sheet T 8000-2 EN.

²⁾ Other pilot valves can be used, provided they have been typetested and the K_v coefficient is large enough to allow the control valve to close within one second.

Table 2: Materials

Control valve		DN 15 and DN 25			
Body		Cast steel 1.0619	Cast stainless steel 1.4408	Forged steel 1.0460	Forged stainless steel 1.4571
Valve bonnet/bellows seal		1.0619	1.4408	1.0460	1.4404/1.4401
Seat and plug	Up to 220 °C (without bellows seal)	1.4404, soft-seated plug seal: PTFE			
	Up to 350 °C (with bellows seal)	1.4404, plug with high-performance metal sealing, optionally stellite seat and plug or plug of solid Stellite			
Guide bushing		1.4104			
Metal bellows		1.4571			
Packing		V-ring packing: PTFE with carbon; spring: 1.4310			
Body gaskets		Graphite on metal core			

Table 3: Dimensions in mm

Valve	DN	15	25
Nominal pressure	PN	16 and 40	
Length L		130	160
Length L1		260	320
Height H1 ¹⁾		220	
Height H2		40	
Version with bellows seal			
Height H4		405	
Actuator	cm ²	350	
Diaphragm Ø D		280	
Height H		82	
Height H3		110	
Thread		M30x1.5	
α		G 3/8 (3/8 NPT)	
α2		G 3/8	

¹⁾ Minimum clearance to remove the actuator

Table 4: Weight (approx.) in kg

Valve	DN	15	25
Valve without actuator		5	7
Valve with actuator		8	10
Actuator	cm ²	350	
Type 3271		8	
Type 3277		12	

Ordering text

Pneumatic Control and Quick-acting Shut-off Valve for Liquid Fuels
 Type 3241-x-Oil

Nominal size DN ...

Nominal pressure PN ...

K_{v5} coefficient ...

Medium temperature ...

Body material According to Table 2

Seat and plug According to Table 2

Characteristic Equal percentage/linear

Bellows seal Without/with

Actuator Type 3271/Type 3277

Effective diaphragm area ... cm²

Pilot valve Type ...

Positioner Type ...

Strainer Without/with

Leakage rate ...

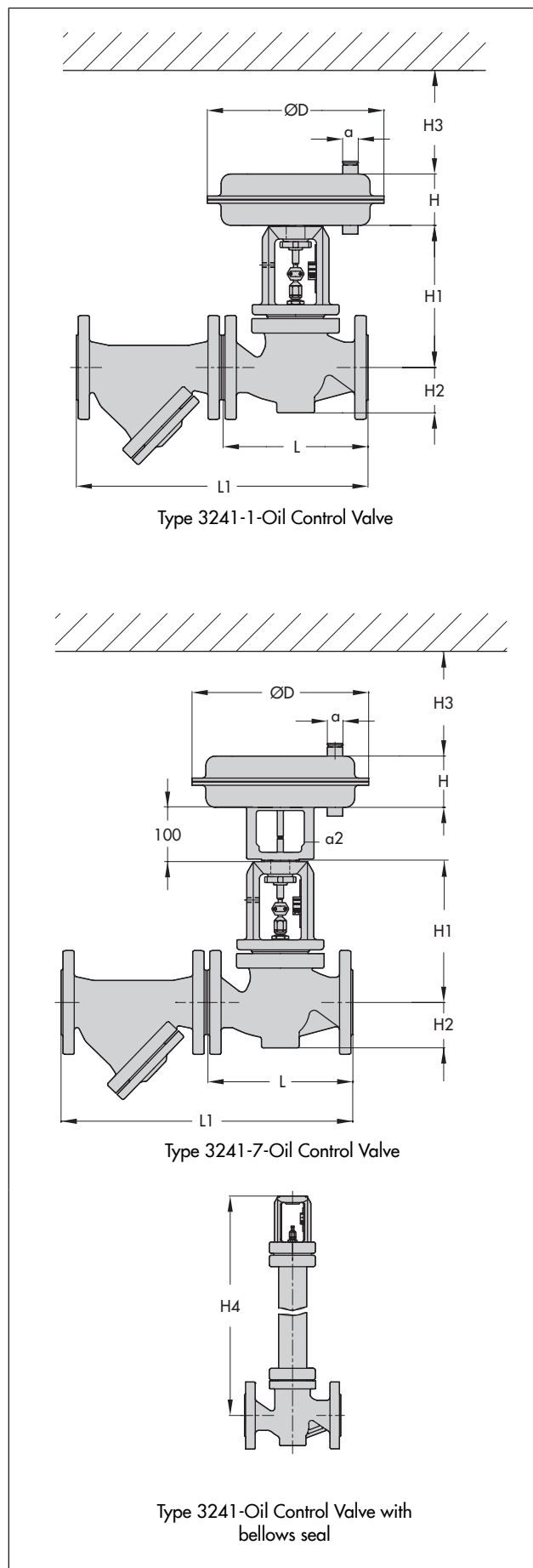

Specifications subject to change without notice.

