

Pneumatic Control Valves Type 3244-1 and Type 3244-7 Three-way Valve Type 3244

DIN and ANSI versions

Application

Mixing or flow-diverting valves for use in process engineering and industrial applications

Nominal size DN 15 to 150 · NPS ½ to 6

Nominal pressure PN 10 to 40 · ANSI Class 150 to 300

Temperatures DIN: -196 to 450 °C · -321 to 842 °F
ANSI: -196 to 450 °C · -321 to 842 °F

Type 3244 Three-way Valve with:

- Type 3271 Pneumatic Actuator (Fig. 1) or
- Type 3277 Pneumatic Actuator (Fig. 2) for integral positioner attachment

Valve body made of:

- Cast iron (DIN version only)
- Cast steel or
- Cast stainless steel

Undivided bonnet

These control valves in modular design can be equipped with various accessories:

Positioners, solenoid valves, limit switches and other accessories according to IEC 60534-6 and NAMUR recommendation (see Information Sheet T 8350 EN for details).

Optional integral positioner attachment with Type 3277 Pneumatic Actuator (see Data Sheet T 8310-1 EN for details).

Versions

Standard version designed for temperatures from -10 °C to +220 °C (15 °F to 430 °F)

- **Type 3244-1** (Fig. 1) · Type 3244 Three-way Valve with Type 3271 Pneumatic Actuator (see Data Sheet T 8310-1 EN)
- **Type 3244-7** (Fig. 2) · Type 3244 Three-way Valve with Type 3277 Pneumatic Actuator (see Data Sheet T 8310-1 EN for details)

Additional versions with:

- **Bellows seal or extension bonnet** · See Technical data
- **Adjustable packing** · Details on request
- **Heating jacket**
- **Additional handwheel** · See Data Sheet T 8310-1 EN

Also available:

- **Type 3244-2 Electric Control Valve** · Details on request
- **Type 3244-3 Manually Operated Valve** with Type 3273 Hand-operated Actuator · See Data Sheet T 8312 EN for details
- **Pneumatic actuators** with 355 or 750 cm² effective diaphragm area · On request



Fig. 1 · Type 3244-1 Pneumatic Control Valve
Type 3271 Actuator

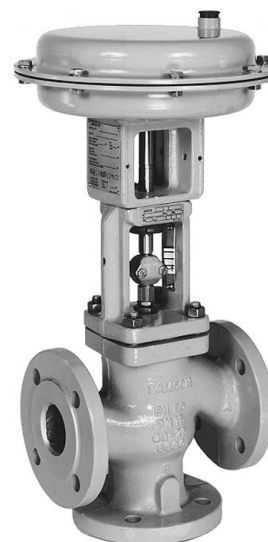

Fig. 2 · Type 3244-7 Pneumatic Control Valve
with Type 3277 Actuator

Principle of operation (Figs. 3 and 4)

Depending on the valve version, the three-way valve can be used for either mixing or flow-diverting service.

In mixing valves, the process media to be mixed enter at valve ports A and B. The combined stream flows off at port AB (see Fig. 3). The flow rate from port A or B to port AB depends on the cross-sectional area of flow between the seats and the valve plugs.

In flow-diverting valves, in contrast, the process medium enters at port AB and the partial streams flow off at ports A and B (see Fig. 4).

Note: The design of the mixing and flow-diverting valves in sizes DN 15 to 25 (NPS ½ to 1) is identical.

Fail-safe position

Depending on the arrangement of the compression springs in the actuator (see Data Sheet T 8310-1 EN for details), the valve has two fail-safe positions which become effective upon supply air failure:

Actuator stem extends (FA)

Whenever the air supply fails, either port B (mixing valve) or port A (flow-diverting valve) is closed.

Actuator stem retracts (FE)

Whenever the air supply fails, either port A (mixing valve) or port B (flow-diverting valve) is closed.

Notes on the differential pressures in Tables 3a to 4b

- Values specified in the gray-shaded columns correspond to the standard bench range
- Differential pressures specified in the white columns apply to maximum pretensioned springs
- Differential pressures in parentheses refer to the values in parentheses in the bench range row
- The tables apply to both fail-safe positions
- The springs in actuators with fail-safe action "Actuator stem retracts" cannot be pretensioned.

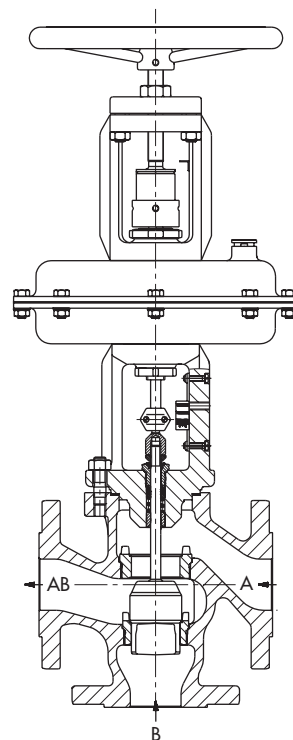

Fig. 3 · Type 3244-1 Pneumatic Control Valve with Type 3244 Three-way Valve (plug arrangement for mixing service (DN 15 to 25 for flow-diverting service as well) and Type 3271 Actuator with additional handwheel

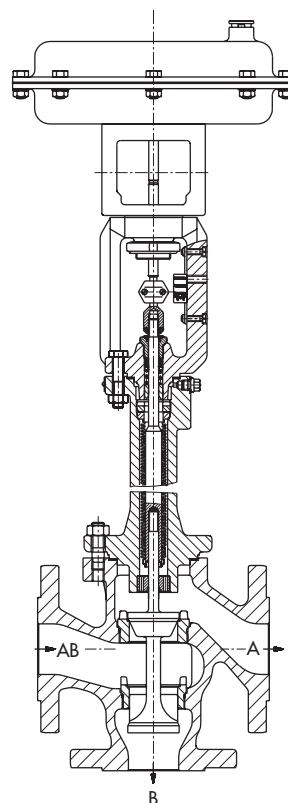

Fig. 4 · Type 3244-7 Pneumatic Control Valve with Type 3244 Three-way Valve, DN 32 to 150 (plug arrangement for flow-diverting service), additional bellows seal and Type 3277 Actuator

Table 1 · Technical data

Version	DIN			ANSI		
Nominal size	DN 15 ... 150			NPS ½ ... 6		
Material	Cast iron EN-JL1040	Cast steel 1.0619	Cast stainless steel 1.4408	Cast steel A 216 WCC	Cast stainless steel A 351 CF8M	
Nominal pressure	PN 10, 16, 25, 40 acc. to DIN 2401			ANSI Class 150 or 300		
End connections	All flange designs acc. to DIN ¹⁾			RF ²⁾		
Seat-plug sealing	Metal			Metal		
Characteristic	Linear			Linear		
Rangeability	50 : 1 for DN 15 ... 50 30 : 1 for DN 65 ... 150			50 : 1 for NPS ½ ... 2 30 : 1 for NPS 2½ ... 6		
Temperature ranges in °C and °F · Permissible operating pressures according to pressure-temperature diagram						
Body without extension bonnet	-10 ... 220 °C			-10 ... 220 °C (15 ... 430 °F)		
Body with	Short extension bonnet ³⁾	-10 ... 300 °C	-10 ... 400 °C ⁴⁾	-10 ... 450 °C ⁴⁾	-29 ... 427 °C (-20 ... 800 °F)	-50 ... 450 °C (-58 ... 842 °F)
	Short bellows seal	-10 ... 300 °C	-10 ... 400 °C ⁴⁾	-10 ... 450 °C ⁴⁾	-29 ... 400 °C (-20 ... 750 °F)	-50 ... 450 °C (-58 ... 842 °F)
Leakage class (IEC 60534-4 and ANSI/FCI 70-2)	0.05 % Kvs			0.05 % Kvs		

¹⁾ Connections for DN 15 only acc. to DIN 2532, 2533, 2543 to 2545

²⁾ Other versions on request

³⁾ Long extension bonnet or bellows seal on request

⁴⁾ Version for lower temperatures on request

Table 2 · Materials

Standard version	DIN			ASTM	
Valve body ¹⁾	Cast iron EN-JL1040	Cast steel 1.0619	Cast stainless steel 1.4408	Cast steel A 216 WCC	Cast stainless steel A 351 CF8M
Valve bonnet	1.0460		1.4401	A 105	A 182 F 316
Seat ²⁾	1.4006		1.4404	Cr steel UNS S 41000	A 182 F 316L
Plug ²⁾	1.4008		1.4404	Cr steel UNS S 41000	A 182 F 316L
Plug sealing	Metal sealing			Metal sealing	
Guide bushings	1.4104		1.4571	A 582 430F	316 Ti
Packing ³⁾	V-ring packing, PTFE with carbon · Spring 1.4310/A 479 302				
Body gaskets	Metal/graphite			Metal/graphite	
Extension bonnet	1.0460		1.4401	A 105	A 182 F316
Metal bellows seal					
Intermediate piece	1.0460		1.4401	A 105	A 182 F316
Metal bellows	1.4571 ⁴⁾			316 Ti	

¹⁾ Special materials for seawater applications: 1.4538, duplex 1.4470, nickel-base alloy 9.4610, other special materials on request

²⁾ All seats and plugs available with Stellite facings, plug made of solid Stellite available up to seat bore 38 for ≤ DN 100

³⁾ Other packings on request (refer to T 8000-1 EN)

⁴⁾ Other materials on request

**Table 3a · K_{vs} coefficients and permissible differential pressures
Type 3244 Mixing Valve · DIN version · Pressures in bar**

Bench range in bar for actuator with effective area					120 cm ²	–	0.4...2.0 (1.2...2.0)	–	1.4...2.3	2.1...3.3
					350 cm ²	0.2...1.0		0.6...3.0 (1.8...3.0)	1.4...2.3 (1.85...2.3)	2.1...3.3 (2.7...3.3)
					700 cm ²					
Required supply pressure in bar					1.2	2.4 (3.2)	3.6 (4.8)	3.7 (4.2)	5.4 (6.0)	
DN	K _{vs} Mixing valve	Seat Ø in mm	Rated travel in mm	Actuator cm ²	Δp when p ₂ = 0 bar					
15	2 · 4	24	15	120	–	5.2	–	29.3	40	
20	2 · 4 · 6.3			350	9.6	23.7	37.8	40	40	
25	2 · 4 6.3 · 10			120	–	–	–	17	27.1	
32 to 50	6.3 · 10 · 16	31		350	5.2	13.6	22.0	40	40	
				120	–	–	–	10.9	17.7	
40 and 50	25	38		350	3.1	8.7	14.3	36.7	40	
				120	–	–	–	6.5	10.7	
50	40	48		350	1.6	5.1	8.6	22.7	35	
				700	–	(40)	(40)	–	–	
				350	1.6	5.1	8.6	22.7	35	
65 80	25 and 40	48		700	–	(40)	(40)	–	–	
				350	–	2.7	4.7	12.9	20	
65 80	60	63		700	–	(23.1)	(35.3)	(36.3)	(40)	
				350	–	1.7	3.1	8.9	13.9	
80	80	75		700	–	(16.1)	(24.7)	(25.5)	37.7	
			1.4	3.9	6.4	16.6	25.4			
100	100	80	30	700	–	2.3	4.0	10.4	16.1	
	160	100			–	3.0	5.0	13	20	
125	140	90			–	1.9	3.2	8.6	13.3	
	200	110			–	1.9	3.2	8.6	13.3	
150	200	110			–	1.2	2.2	6.0	9.4	
	300	130			–					

**Table 3b · Cv coefficients and permissible differential pressures
Type 3244 Mixing Valve · ANSI version · Pressures in psi**

Bench range in psi for actuator with effective area						120 cm ²	–	6...30 (18...30)	–	20...34	30...48
						350 cm ²	3...15		9...45 (26...45)	20...34 (26...34)	30...48 (39...48)
						700 cm ²	–	–	–	–	–
Required supply pressure in psi						18	35 (47)	52 (70)	54 (61)	78 (87)	
Nom. size		Cv Mixing valve	Seat Ø in inch (mm)	Rated travel in inch (mm)	Actuator cm ²	Δp when p ₂ = 0 psi					
NPS	DN					–	–	–	–	–	
½	15	2.3 · 5	0.94 (24)	0.59 (15)	120	–	75	–	425	580	
	¾	20			2.3 · 5 · 7.5	350	139	344	548	580	580
		1			25	2.3 · 5 7.5 · 12	120	–	–	–	247
1½ and 2	40 and 50	7.5 · 12 · 20	1.22 (31)		350	75	197	319	580	580	
		30	1.49 (38)		120	–	–	–	158	257	
	2	50	47		1.89 (48)	350	45	126	207	532	580
						700	–	(580)	(580)	–	–
2½ 3	65 80	30 and 47	1.89 (48)		350	23	74	125	329	508	
					700	–	(580)	(580)	–	–	
	3	80	95		2.48 (63)	350	–	39	68	187	290
						700	–	(335)	(512)	(526)	(580)
3	80	95	2.95 (75)		350	–	25	45	129	202	
					700	–	(233)	(358)	(370)	547	
4	100	120	3.15 (80)		1.18 (30)	700	20	57	93	241	368
		190	3.93 (100)				–	33	58	151	233
6	150	230	4.33 (110)	–			28	46	125	193	
		350	5.12 (130)	–			17	32	87	136	

**Table 4a · K_{Vs} coefficients and permissible differential pressures
Type 3244 Flow-diverting Valve · DIN version · Pressures in bar**

Valves in DN 65 to 150: Direction of flow AB ⇒ A with maximum K_{Vs} and
AB ⇒ B with reduced K_{Vs}

Bench range in bar for actuator with effective area		120 cm ²	–	0.4...2.0 (1.2...2.0)	–	1.4...2.3	2.1...3.3		
		350 cm ²	0.2...1.0		0.6...3.0 (1.8...3.8)	1.4...2.3 (1.85...2.3)	2.1...3.3 (2.7...3.3)		
		700 cm ²	–		–	–	–		
Required supply pressure in bar			1.2	2.4 (3.2)	3.6 (4.8)	3.7 (4.2)	5.4 (6.0)		
DN	K _{Vs} Diverting valve	Seat Ø in mm	Rated travel in mm	Actuator cm ²	Δp when p ₂ = 0 bar				
15	2 · 4	24	15	120	–	5.2	–	29.3	40
20	2 · 4 · 6.3			350	9.6	23.7	37.8	40	40
25	2 · 4 6.3 · 10			120	–	–	–	17	27.1
32 to 50	6.3 · 10 · 16	31		350	5.2	13.6	22.0	40	40
				120	–	–	–	10.9	17.7
40 and 50	25	38		350	3.1	8.7	14.3	36.7	40
				120	–	–	–	6.5	10.7
50 to 80	40	48		350	1.6	5.1	8.6	22.7	35
				700	–	(40)	(40)	–	–
65 80	25 and 40	48		350	1.6	5.1	8.6	22.7	35
				700	–	(40)	(40)	–	–
65	60/40	63/48		350	–	2.7	4.7	12.9	20
				700	–	(23.1)	(35.3)	(36.3)	(40)
80	60	63		350	–	2.7	4.7	12.9	20
				700	–	(23.1)	(35.3)	(36.3)	(40)
80	80/60	75/63	350	–	1.7	3.1	8.9	13.9	
			700	–	(16.1)	(24.7)	(25.5)	(37.7)	
100	100	80	30	700	1.4	3.9	6.4	16.6	25.4
	160/100	100/80			–	2.3	4.0	10.4	16.1
125	140	90			–	3.0	5.0	13	20
	200/140	110/90			–	1.9	3.2	8.6	13.3
150	200	110			–	1.9	3.2	8.6	13.3
	300/200	130/110			–	1.2	2.2	6.0	9.4

Table 4b · Cv coefficients and permissible differential pressures
Type 3244 Flow-diverting Valve · ANSI version · Pressures in psi

Valves in NPS 2½ to 6: Direction of flow AB ⇒ A with maximum Cv and
 AB ⇒ B with reduced Cv

Bench range in psi for actuator with effective area					120 cm ²	–	6...30 (18...30)	–	20...34	30...48
					350 cm ²	3...15		9...45 (26...45)	20...34 (26...34)	30...48 (39...48)
					700 cm ²		18	35 (47)	52 (70)	54 (61)
Required supply pressure in psi										
Nom. size		Cv Diverting valve	Seat Ø in inch (mm)	Rated travel in inch (mm)	Actuator cm ²	Δp when p ₂ = 0 psi				
NPS	DN									
½	15	2.3 · 5	0.94 (24)	0.59 (15)	120	–	75	–	425	580
	¾	2.3 · 5 · 7.5			350	139	344	548	580	580
		1			2.3 · 5 7.5 · 12	120	–	–	–	247
1½ and 2	40 and 50	7.5 · 12 · 20	1.22 (31)		350	75	197	319	580	580
		30	1.49 (38)		120	–	–	–	158	257
2 to 3	50 to 80	47	1.89 (48)		350	45	126	207	532	580
					120	–	–	–	94	155
					700	–	(580)	(580)	–	–
2½ 3	65 80	30 and 47	1.89 (48)		350	23	74	125	329	508
					700	–	(580)	(580)	–	–
		70	2.48 (63)		350	–	39	68	187	290
					700	–	(335)	(512)	(526)	(580)
3	80	95/70	2.95/2.48 (75/63)	350	–	25	45	129	202	
				700	–	(233)	(358)	(370)	547	
4	100	120	3.15 (80)	1.18 (30)	700	20	57	93	241	368
		190/120	3.93/3.15 (100/80)			–	33	58	151	233
6	150	230	4.33 (110)			–	28	46	125	193
		350/230	5.12/4.33 (130/110)			–	17	32	87	136

Table 5 · Dimensions
Table 5a · Type 3244 Valve · DIN version

Valve	DN	15	20	25	32	40	50	65	80	100	125	150
Length L	mm	130	150	160	180	200	230	290	310	350	400	480
H1	mm	235						270		360	375	
H2	mm	70	80	85	100	105	120	130	140	150	200	210

Table 5b · Type 3244 Valve · ANSI version

Valve size	NPS	1/2	3/4	1	1 1/2	2	2 1/2	3	4	6	
	DN	15	20	25	40	50	65	80	100	150	
Length	Class 150	mm	184	184	184	222	254	276	298	352	451
		inch	7.25	7.25	7.25	8.75	10.0	10.87	11.75	13.87	17.75
	Class 300	mm	190	194	197	235	267	292	318	368	473
		inch	7.50	7.62	7.75	9.25	10.50	11.50	12.50	14.50	18.62
H1	mm	235						270		360	375
	inch	9.25						10.63		14.17	14.76
H2	Class 150	mm	92	92	92	111	127	138	149	176	225.5
		inch	3.62	3.62	3.62	4.37	5.0	5.43	5.87	6.93	8.88
	Class 300	mm	95	97	98.5	117.5	133.5	146	159	184	236.5
		inch	3.76	3.82	3.88	4.63	5.26	5.75	6.26	7.24	9.31

Table 5c · Type 3271 and Type 3277 Actuators

Effective diaphragm area	cm ²	120	350	700
Diaphragm Ø	mm	168	280	390
H	mm	69	82	138
	inch	2.71	3.23	5.43
H3 (Types 3271 and 3277)	mm	110		190
	inch	4.33		7.48
H5	mm	88	101	
	inch	3.46	3.98	
Thread		M30 x 1.5		
a with Type 3271		G 1/4 (1/4 NPT)		G 3/8 (3/8 NPT)
a2 with Type 3277		-		G 3/8

Table 5d · Version with short or long extension bonnet or bellows seal

Valve size	DN	15	20	25	32	40	50	65	80	100	125	150
	NPS	1/2	3/4	1	-	1 1/2	2	2 1/2	3	4	-	6
H4 with	Short extension bonnet or bellows seal	mm	420						455	645	655	
		inch	16.54						17.91	25.39	25.79	
	Long extension bonnet or bellows seal	mm	725						760	895	900	
		inch	28.54						29.92	35.24	35.43	

Table 6 · Weights

Table 6a · Type 3244 Valve

Valve size	DN	15	20	25	32	40	50	65	80	100	125	150	
	NPS	½	¾	1	–	1½	2	2½	3	4	–	6	
Valve without actuator	kg	6	7	8	13	15	17	31	37	49	95	135	
	lbs	13	15.5	17.5	28.7	33	37.5	68	82	108	210	298	
Weight with extension bonnet or bellows seal	Short	kg	9	10	11	19	21	23	40	45	68	120	165
		lbs	20	22	24	42	46.3	50.7	88	99	150	265	364
	Long	kg	13	14	15	23	25	27	44	49	76	128	173
		lbs	28.7	30.9	33	50.7	55	59.5	97	108	168	282	382

Table 6b · Type 3271 and Type 3277 Actuators

Actuator	cm ²	120	350	700
	in ²	18.6	54.2	108.5
Weight for Type 3271 without	kg	2	8	22
	lbs	4.4	18	48.5
Weight for Type 3271 with handwheel	kg	–	13	27
	lbs	–	29	59.5
Weight for Type 3277 without	kg	3.2	12	26
	lbs	7.05	26.5	57.5
Weight for Type 3277 with handwheel	kg	–	17	31
	lbs	–	37.5	68

Dimensional diagrams

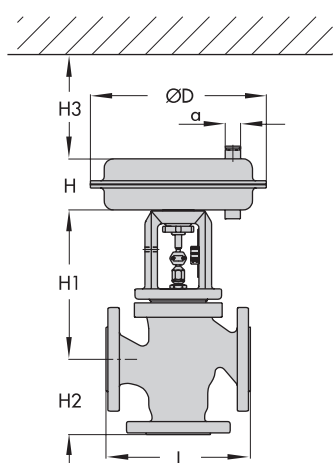

Type 3244 Valve with Type 3271 Actuator

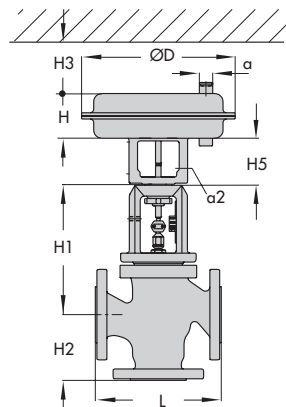

Type 3244 Valve with Type 3277 Actuator

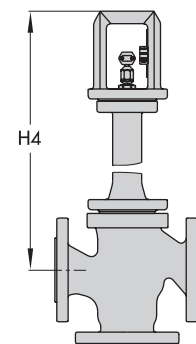

Type 3244 Valve with extension bonnet or bellows seal

Ordering text

Mixing or flow-diverting valve

Nominal size	DN ... / NPS ...
Nominal pressure	PN ... / Class ...
Body material	According to Table 2
Actuator	Type 3271 or Type 3277
Fail-safe position	Actuator stem extends or actuator stem retracts
Process medium and its density in temperature in	kg/m ³ or lb/ft ³ °C or °F
Flow rate in in standard or operating state	kg/h or cu. ft/min
Upstream pressure	p ₁ in bar or psi (absolute pressure p _{abs})
Downstream pressure	p ₂ in bar or psi (absolute pressure p _{abs}) with minimum, normal and maximum flow rate
Accessories	Positioner and/or limit switch

Specifications subject to change without notice.



SAMSON AG · MESS- UND REGELTECHNIK
Weismüllerstraße 3 · 60314 Frankfurt am Main · Germany
Phone: +49 69 4009-0 · Fax: +49 69 4009-1507
Internet: <http://www.samson.de>

T 8026 EN

2011-12