

Pneumatic Control Valve Type 3246-1 and Type 3246-7



Globe Valve Type 3246

ANSI Class 150 and 300 with long insulating section and circulation inhibitor
ANSI version

Application

Globe valve for cryogenic applications

Nominal size NPS ½ to 10
Pressure rating ANSI Class 150 and 300
Temperatures -200 to 220 °C · -328 to 428 °F

Type 3246 Globe Valve with

- Type 3271 Pneumatic Actuator (Type 3246-1 Control Valve) or
- Type 3277 Pneumatic Actuator (Type 3246-7 Control Valve)

Valve body made of:

- Stainless carbon steel

Low-noise valve plug with:

- Metal sealing or
- Lapped-in metal

The modular design of the control valves allows them to be equipped with various accessories:

Positioners, solenoid valves and other accessories according to IEC 60534-6 and NAMUR recommendation. See Information Sheet T 8350 EN for details.

Version

Standard version with single PTFE packing for temperatures ranging from -200 to 220 °C (-328 to 428 °F) with long insulating section and circulation inhibitor, nominal size NPS ½ to 10, ANSI Class 150 and 300, with flanges with Raised Face or welding ends

- **Type 3246-1** (Fig. 1) · With Type 3271 Actuator with 120 to 2800 cm² effective diaphragm area (refer to T 8310-1 EN and T 8310-2 EN)
- **Type 3246-7** · With Type 3277 Actuator with 120 to 700 cm² effective diaphragm area (refer to T 8310-1 EN)

Other versions

- **Type 3246-1/-7 Globe Valve** · With long insulating section and circulation inhibitor, NPS ½ to 8, ANSI Class 600 · Refer to Data Sheet T 8046-2 EN
- **Type 3246-1/-7 Globe Valve** · With long insulating section and circulation inhibitor, NPS ½ to 6, ANSI Class 150 and 300 · Refer to Data Sheet T 8046-3 EN

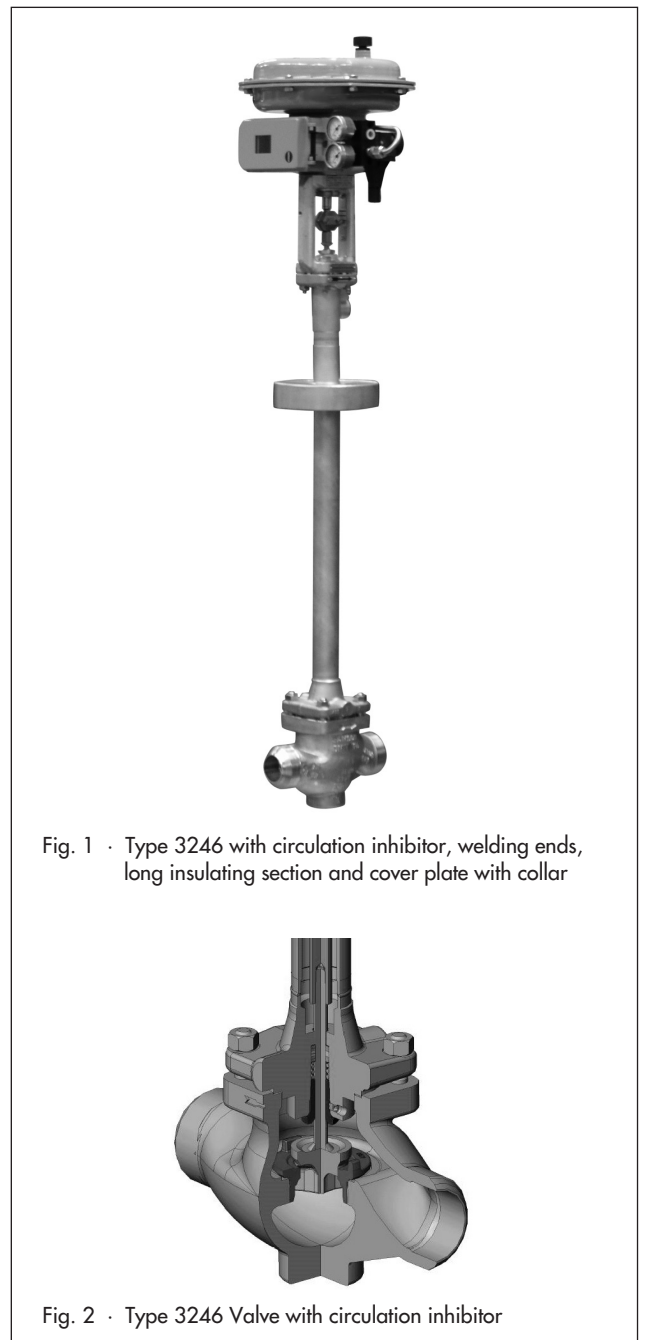

Fig. 1 · Type 3246 with circulation inhibitor, welding ends, long insulating section and cover plate with collar

Fig. 2 · Type 3246 Valve with circulation inhibitor

Principle of operation

The process medium flows through the valve in the flow-to-open direction. The position of the valve plug determines the cross-sectional area of flow between the seat and plug. The circulation inhibitor at the bottom minimizes the effects of the medium flow in the insulating section.

Fail-safe positions

Depending on how the compression springs are arranged in the actuator (see Data Sheets T 8310-1 EN and T 8310-2 EN for details), the control valve has two different fail-safe positions which become effective upon supply air failure:

Actuator stem extends (FA)

The actuator springs close the valve when the supply air fails.

Actuator stem retracts (FE)

The actuator springs open the valve when the supply air fails.

Servicing instructions · For trained personnel only

Installation in the pipeline

It is not necessary to remove the insulating section to weld the body in the pipeline.

Please note that the temperature at the point of connection from the valve body to the insulating section should not exceed 220 °C.

Lubricant

- Apply lubricant (order no. 8150-0116) to the plug stem (6), seat (2) and plug (3).
- Prior to assembling the valve, apply lubricant (order no. 8150-0116) to the thread of the valve bonnet (5 or 5.1), yoke (7), stem connector nut (6.1) and stem connector (6.2)

Packing at the top

The packing only needs to be serviced or replaced when leakage occurs.

Prior to installation, apply lubricant (8150-0116) to the plug stem.

Standard packing (Fig. 3) with spring (4.1), self-adjusting

Apply lubricant (order no. 8150-0116) to all parts.

Tighten threaded bushing (5.2) on assembly.

Insulating section (Fig. 4)

To perform maintenance work on the seat or plug, remove the bonnet (5.1) together with intermediate piece (8).

The bonnet (5.1) only needs to be removed on performing work on the packing.

Circulation inhibitor (Fig. 5)

A spring-loaded circulation inhibitor is used in place of a bottom metal guided bushing.

Prior to removing or assembling the plug, unscrew the hex socket headless screw at the side. The threaded bushing of the circulation inhibitor can only be removed after the headless screw has first been unscrewed.

On replacing the seals at the circulation inhibitor, insert the spring between the seals and threaded bushing.

Mounting and Operating Instructions

Refer to EB 8015 EN for more instructions on how to mount the actuator, installation, operation and maintenance (Type 3241 Globe Valve).

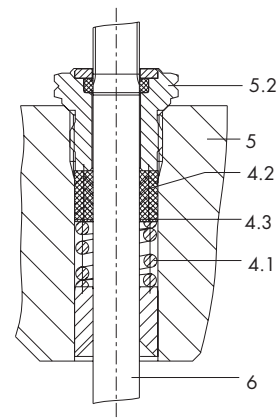

Fig. 3 · Standard packing

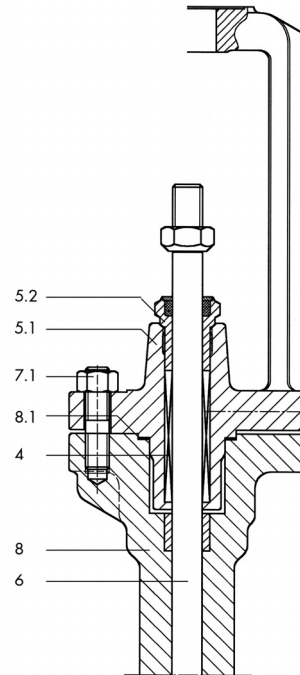

Fig. 4 · Yoke on the intermediate piece of the insulating section

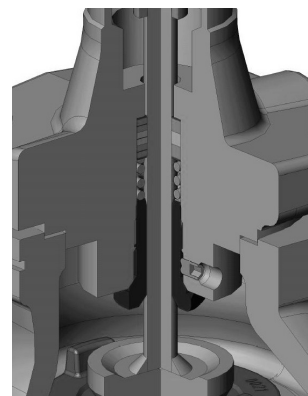

Fig. 5 · Circulation inhibitor and hex socket headless screw

Table 1 · Technical data for Type 3246 with circulation inhibitor

| | | |
|---|---|-----------------------------------|
| Material | Stainless carbon steel A 351 CF8 | |
| Nominal size | NPS ½ ... 10 | |
| Pressure rating | ANSI Class 150 or 300 | |
| End connections | ANSI flanges with Raised Face · Welding ends | |
| Seat-plug sealing | Metal sealing · Lapped-in metal · Stellite facing | |
| Characteristic | Equal percentage · Linear · Quick opening | |
| Rangeability | 50 : 1 · 30 :1 for NPS 3 and larger | |
| Temperature ranges in °C (°F) · Permissible operating pressures according to pressure-temperature diagrams (see Information Sheet T 8000-2 EN) | | |
| Valve with | PTFE packing | -200 ... 220 °C (-328 ... 428 °F) |
| Leakage class according to EN 1349 | | |
| Valve plug | Metal sealing | IV |
| | Lapped-in metal | IV-S2 · IV-S1: NPS 4 and larger |

Table 2 · Materials

| | | |
|--------------------------------------|-------------------------------------|---|
| Standard version Body and flanges | Stainless carbon steel A 351 CF8 | |
| Seat and plug ¹⁾ | Metal sealing | CrNiMo |
| Guided bushings | CrNiMo | |
| Packing | Self-adjusting | PTFE-carbon V-ring packing, spring 1.4310 |
| Circulation inhibitor | NPS ½ to 6 | PTFE-silk cord, spring-loaded, bushing 2.4360 (Monel) |
| | NPS 8 to 10 | PTFE-silk cord, spring-loaded, bushing 2.0402 (CuZn40Pb2) |
| Body gasket | Graphite with metal core | |
| Insulating section | A182 F316 | |

¹⁾ Seats and metal-seated plugs are also available with stellite facing or plug made of solid Stellite.

Table 3 · K_{V5} and C_V coefficients
Table 3a · Overview

| C _V | 0.12 | 0.2 | 0.3 | 0.5 | 0.75 | 1.2 | 2 | 3 | 5 | 7.5 | 12 | 20 | 30 | 47 | 70 | 75 | 95 | 120 | 190 | 300 | 420 | 735 | 1150 |
|-----------------|------|------|------|------|------|------|-----|-----|-------|-----|------|-----|-----|------|----|------|------|------|------|------|------|------|------|
| K _{V5} | 0.1 | 0.16 | 0.25 | 0.4 | 0.63 | 1.0 | 1.6 | 2.5 | 4.0 | 6.3 | 10 | 16 | 25 | 40 | 60 | 63 | 80 | 100 | 160 | 260 | 360 | 630 | 1000 |
| Seat Ø D | in | 0.12 | | 0.24 | | 0.47 | | | 0.945 | | 1.22 | 1.5 | 1.9 | 2.48 | | 3.15 | | 3.94 | 5.12 | 5.91 | 7.87 | 9.84 | |
| | mm | 3 | | 6 | | 12 | | | 24 | | 31 | 38 | 48 | 63 | | 80 | | 100 | 130 | 150 | 200 | 250 | |
| Rated travel | in | 0.59 | | | | | | | | | | | | | | 1.18 | 0.59 | 1.18 | | 2.36 | | 4.72 | |
| | mm | 15 | | | | | | | | | | | | | | 30 | 15 | 30 | | 60 | | 120 | |

Table 3b · Versions

| C _V | 0.12 | 0.2 | 0.3 | 0.5 | 0.75 | 1.2 | 2 | 3 | 5 | 7.5 | 12 | 20 | 30 | 47 | 70 | 75 | 95 | 120 | 190 | 300 | 420 | 735 | 1150 |
|-----------------|------|------|------|-----|------|-----|-----|-----|-----|-----|----|----|----|----|----|----|----|-----|-----|-----|-----|-----|------|
| K _{V5} | 0.1 | 0.16 | 0.25 | 0.4 | 0.63 | 1.0 | 1.6 | 2.5 | 4.0 | 6.3 | 10 | 16 | 25 | 40 | 60 | 63 | 80 | 100 | 160 | 260 | 360 | 630 | 1000 |
| NPS | DN | | | | | | | | | | | | | | | | | | | | | | |
| ½ | 15 | • | • | • | • | • | • | • | • | | | | | | | | | | | | | | |
| ¾ | 20 | • | • | • | • | • | • | • | • | • | | | | | | | | | | | | | |
| 1 | 25 | • | • | • | • | • | • | • | • | • | • | | | | | | | | | | | | |
| 1½ | 40 | | | | • | • | • | • | • | • | • | • | • | | | | | | | | | | |
| 2 | 50 | | | | • | • | • | • | • | • | • | • | • | • | | | | | | | | | |
| 3 | 80 | | | | | | | | | | | | • | • | • | | • | | | | | | |
| 4 | 100 | | | | | | | | | | | | | | | • | | • | • | | | | |
| 6 | 150 | | | | | | | | | | | | | | | • | | • | • | • | | | |
| 8 | 200 | | | | | | | | | | | | | | | | | | | | • | • | |
| 10 | 250 | | | | | | | | | | | | | | | | | | | | • | • | • |

Table 4 · Differential pressure tables

Values specified in shaded columns apply to standard cases, i.e. application at rated travel · Differential pressures specified in white columns apply to maximum pretensioned springs · Differential pressures in parentheses apply to half travel.
Read the note concerning differential pressures.

Table 4a · Permissible differential pressures Δp · Pressures in bar

For valves with fail-safe position "Actuator stem extends" · Valve closed at a signal pressure of 0 bar.

| Bench range (bar) for actuators (cm ²) | 240 | | 0.2...1.0 | 0.3...1.1 | 0.4...2.0 (1.2...2.0) | 0.6...2.2 | 0.6...3.0 ¹⁾ (1.8...3.0) | 0.9...3.3 | – | – |
|--|-------------------|--------------------------|--|-----------|--------------------------|-----------|--|-----------|---------------------------|--------------------------|
| | 120, 350, 700 | 1400 | – | 0.4...1.2 | | 0.8...2.4 | | 1.2...3.6 | 1.4...2.3 (1.85...2.3) | 2.1...3.3 (2.7...3.3) |
| 2800 | – | – | – | 0.8...1.2 | – | 1.6...2.4 | – | 2.4...3.6 | – | – |
| Required supply pressure (bar) | 1.2 | | 1.2 | 1.4 | 2.2 | 2.6 | 3.2 | 3.8 | 2.5 | 3.5 |
| Nom. size NPS | C _v | Actuator cm ² | Δp when p ₂ = 0 bar | | | | | | | |
| ½ to 1 | 0.12 to 0.3 | 120 | 22 | – | 49 | – | – | – | – | – |
| | | 240 | 49 | 50 | – | – | – | – | – | – |
| ½ to 2 | 0.5 to 1.2 | 120 | 22 | – | 49 | – | – | – | – | – |
| | | 240 | 49 | 50 | 50 | – | – | – | – | – |
| | 2 3 5 | 120 | 9 | – | 28 | – | – | – | 50 | – |
| | | 240 | 28 | 47 | 50 | 50 | 50 | 50 | – | – |
| ¾ to 2 | 7.5 12 | 350 | 45 | 50 | 50 | 50 | 50 | – | 50 | – |
| | | 120 | – | – | 5.5 | – | – | – | 30 | 46 |
| | | 240 | 5.2 | 9.3 | 14.8 | 24 | 24 | 39 | – | – |
| | | 350 | 10 | 24 | 24 | 38 | 38 | 50 | 50 | 50 |
| 1½ and 2 | 20 | 700 | – | – | (50) | – | – | – | – | – |
| | | 120 | – | – | 3 | – | – | – | 18 | 28 |
| | | 240 | 2.5 | 5.2 | 8.0 | 14 | 14 | 23 | – | – |
| | | 350 | 5.2 | 13.5 | 13.5 | 30 | 22 | 47 | 50 | 50 |
| 1½ to 3 | 30 | 700 | – | – | (50) | – | (50) | – | – | – |
| | | 120 | – | – | 1.5 | – | – | – | 12 | 19 |
| | | 240 | 1.3 | 3.1 | 5.0 | 9.0 | 9.0 | 15 | – | – |
| | | 350 | 3.1 | 8.5 | 8.5 | 20 | 14 | 31 | 37 | 50 |
| 2 and 3 | 47 | 700 | – | – | (40) | – | (50) | – | – | – |
| | | 240 | – | – | 3.0 | 5.0 | 5.0 | 9.0 | – | – |
| | | 350 | 1.6 | 5.0 | 5.0 | 12 | 8.5 | 19 | 23 | 35 |
| 3 | 70 | 700 | – | – | (23) | – | (35) | – | (36) | (50) |
| | | 240 | – | – | 1.4 | 2.8 | 2.8 | 5.0 | – | – |
| | | 350 | 0.8 | 2.7 | 2.7 | 6.5 | 4.5 | 10.5 | 13 | 20 |
| 3 | 95 | 700 | – | – | 1.4 | – | (21) | – | (22) | (33) |
| | | 240 | – | – | 0.6 | 1.5 | 1.5 | 2.8 | – | – |
| | | 350 | – | 1.4 | 1.4 | 4.0 | 2.7 | 6.5 | 8 | 12 |
| 4 | 75 | 700 | 2.6 | 6.5 | 6.5 | 15 | 10.5 | 23 | 27 | 41 |
| 4 | 120 | 700 | 1.4 | 4.0 | 4.0 | 9.0 | 6.5 | 14 | 16.5 | 25 |
| 4 6 | 190 | 700 | 0.7 | 2.3 | 2.3 | 5.5 | 4.0 | 8.5 | 10.5 | 15.5 |
| 6 | 300 | 700 | 0.3 | 1.2 | 1.2 | 3.0 | 2.2 | 6.0 | 6.0 | 9.5 |
| 8 to 10 | 290 | 1400 | – | 3.4 | 3.4 | 7.5 | – | – | – | – |
| | | 2800 | – | 15.8 | – | 32.4 | – | 48 | – | – |
| | 420 | 1400 | – | 2.3 | 2.3 | 5.1 | – | – | – | – |
| | | 2800 | – | 10.8 | – | 22.4 | – | 33.9 | – | – |
| | 735 | 1400 | – | – | – | 2.8 | – | – | – | – |
| | | 2800 | – | 6 | – | 12.5 | – | 19 | – | – |
| 10 | 1150 | 2800 | – | – | – | – | – | 5.8 | – | – |
| | | 2x2800 | – | – | – | 7.4 | – | 11.6 | – | – |

1) Not for actuator with 120 cm² effective area

Table 4b · Permissible differential pressures Δp · Pressures in psi

For valves with fail-safe position "Actuator stem extends" · Valve closed at a signal pressure of 0 bar.

| Bench range (psi) for actuators (cm ²) | 240 | | 3...15 | 4...17 | 6...30 (18...30) | 9...32 | 9...44 ¹⁾ (26...44) | 13...48 | - | - | |
|--|-------------------|-----------------------------|--|---------|---------------------|---------|-----------------------------------|---------|----------------------|----------------------|---|
| | 120, 350, 700 | | | 6...18 | | 12...35 | | 18...52 | 20...34 (26...34) | 30...48 (39...48) | |
| | 1400 | | - | - | - | - | - | | | | |
| | 2800 | | - | 12...18 | - | 23...35 | - | 34...52 | - | - | |
| Required supply pressure (psi) | | | 18 | 21 | 33 | 38 | 47 | 55 | 38 | 55 | |
| Nom. size NPS | Cv | Actuator cm ² | Δp when p ₂ = 0 psi | | | | | | | | |
| ½ to 1 | 0.12 to 0.3 | 120 | 320 | - | 710 | - | - | - | - | - | |
| | | 240 | 710 | 725 | - | - | - | - | - | - | |
| ½ to 2 | 0.5 to 1.2 | 120 | 320 | - | 710 | - | - | - | - | - | |
| | | 240 | 725 | 725 | 725 | - | - | - | - | - | |
| | 2 3 5 | 120 | 130 | - | 405 | - | - | - | 725 | - | |
| | | 240 | 406 | 680 | 725 | 725 | 725 | 725 | 725 | - | |
| 350 | 650 | 725 | 725 | 725 | 725 | 725 | - | 725 | - | | |
| ¾ to 2 | 7.5 12 | 120 | - | - | 80 | - | - | - | 435 | 665 | |
| | | 240 | 75 | 135 | 215 | 350 | 350 | 565 | - | - | |
| | | 350 | 145 | 350 | 350 | 550 | 550 | 725 | 725 | 725 | |
| | | 700 | - | - | (725) | - | - | - | - | - | |
| 1½ and 2 | 20 | 120 | - | - | 44 | - | - | - | 260 | 405 | |
| | | 240 | 36 | 75 | 115 | 200 | 200 | 335 | - | - | |
| | | 350 | 75 | 195 | 195 | 435 | 320 | 680 | 725 | 725 | |
| | | 700 | - | - | (725) | - | (725) | - | - | - | |
| 1½ to 3 | 30 | 120 | - | - | 22 | - | - | - | 175 | 275 | |
| | | 240 | 19 | 45 | 72 | 130 | 130 | 218 | - | - | |
| | | 350 | 45 | 125 | 125 | 290 | 200 | 450 | 535 | 725 | |
| | | 700 | - | - | (725) | - | (725) | - | - | - | |
| 2 and 3 | 47 | 240 | - | - | 43 | 72 | 72 | 130 | - | - | |
| | | 350 | 23 | 72 | 72 | 175 | 123 | 275 | 330 | 507 | |
| | | 700 | - | - | (580) | - | (725) | - | - | - | |
| 3 | 70 | 240 | - | - | 20 | 40 | 40 | 72 | - | - | |
| | | 350 | 12 | 39 | 39 | 94 | 65 | 152 | 190 | 290 | |
| | | 700 | - | - | (333) | - | (507) | - | (520) | (725) | |
| 3 | 95 | 240 | - | - | 9 | 22 | 22 | 40 | - | - | |
| | | 350 | - | 20 | 20 | 58 | 39 | 94 | 115 | 174 | |
| | | 700 | - | - | 20 | - | (305) | - | (320) | (475) | |
| 4 | 75 | 700 | 38 | 94 | 94 | 217 | 152 | 333 | 390 | 595 | |
| 4 | 120 | 700 | 20 | 58 | 58 | 130 | 94 | 203 | 239 | 362 | |
| 4 6 | 190 | 700 | 10 | 33 | 33 | 80 | 58 | 123 | 152 | 225 | |
| 6 | 300 | 700 | 4.4 | 17 | 17 | 43 | 32 | 85 | 85 | 135 | |
| | | | 290 | 1400 | - | 49 | 49 | 110 | - | - | - |
| | | 2800 | - | 230 | - | 470 | - | 695 | - | - | |
| | | 420 | 1400 | - | 33 | 33 | 74 | - | - | - | - |
| | | | 2800 | - | 157 | - | 325 | - | 490 | - | - |
| | | 735 | 1400 | - | - | - | 41 | - | - | - | - |
| 2800 | - | | 87 | - | 181 | - | 276 | - | - | | |
| 10 | 1150 | 2800 | - | - | - | - | - | 85 | - | - | |
| | | 2x2800 | - | - | - | 108 | - | 170 | - | - | |

1) Not for actuator with 120 cm² effective area

Tables 4c and 4d · Permissible differential pressures Δp

For valves with fail-safe position "Actuator stem retracts" · Valve closed at required signal pressure

| Bench range in (bar/psi) for actuators (cm ²) | | | Table 4c · Pressures in bar | | | Table 4d · Pressures in psi | | | |
|---|-------------------|-----------------------------|--|---------------|------|--|------------|-------|--|
| | | | 120 ... 2800 ¹⁾ | 0.2 ... 1.0 | | | 3 ... 15 | | |
| | | | 1400 | (0.4 ... 2.0) | | | (6 ... 30) | | |
| | | | 2800 | (0.3 ... 1.1) | | | (4 ... 17) | | |
| Required supply pressure (bar/psi) | | | 1.2 | 2.4 | 4 | 18 | 36 | 58 | |
| Size NPS | C _v | Actuator cm ² | Δp when p ₂ = 0 bar | | | Δp when p ₂ = 0 psi | | | |
| ½ to 1 | 0.12 to 0.3 | 120 | 23 | 50 | – | 330 | 725 | – | |
| | | 240 | 49 | – | – | 710 | – | – | |
| ½ to 2 | 0.3 to 1.2 | 120 | 23 | 50 | – | 330 | 725 | – | |
| | | 240 | 49 | 50 | – | 710 | 725 | – | |
| | 2 3 5 | 120 | 9 | 50 | – | 130 | 725 | – | |
| | | 240 | 28 | 50 | – | 410 | 725 | – | |
| ¾ to 2 | 7.5 12 | 350 | 45 | 50 | – | 650 | 725 | – | |
| | | 120 | 0.6 | 31 | 50 | 10 | 450 | 725 | |
| | | 240 | 5.2 | 50 | 50 | 80 | 725 | 725 | |
| | | 350 | 10 | 50 | 50 | 145 | 725 | 725 | |
| 1½ and 2 | 20 | 700 | (24) | (50) | – | (350) | (725) | – | |
| | | 120 | – | 18 | 40 | – | 260 | 580 | |
| | | 240 | 2.5 | 37 | 50 | 35 | 540 | 725 | |
| | | 350 | 5.2 | 50 | 50 | 75 | 725 | 725 | |
| 1½ to 3 | 30 | 700 | (13.5) | (50) | – | (200) | (725) | – | |
| | | 120 | – | 11 | 28 | – | 160 | 410 | |
| | | 240 | 1.3 | 24 | 50 | 20 | 350 | 725 | |
| | | 350 | 3.1 | 37 | 50 | 45 | 540 | 725 | |
| 2 and 3 | 47 | 700 | (8.7) | (50) | (50) | (130) | (725) | (725) | |
| | | 240 | 0.5 | 15 | 34 | 10 | 220 | 490 | |
| | | 350 | 1.6 | 23 | 50 | 25 | 330 | 725 | |
| 3 | 70 | 700 | (5.0) | (46) | (50) | (75) | (665) | (725) | |
| | | 240 | – | 8.5 | 20 | – | 120 | 290 | |
| | | 350 | 0.6 | 13 | 29 | 10 | 190 | 420 | |
| 3 | 95 | 700 | (2.7) | (27) | (50) | (40) | (390) | (725) | |
| | | 240 | – | 5.0 | 12 | – | 75 | 170 | |
| | | 350 | 0.2 | 7.8 | 18 | 5 | 110 | 260 | |
| 4 | 75 | 700 | (1.4) | (16) | (37) | (20) | (230) | (540) | |
| 4 | 120 | 700 | 2.6 | 27 | 50 | 40 | 390 | 725 | |
| 4 and 6 | 190 | 700 | 1.4 | 16 | 36 | 20 | 230 | 520 | |
| 4 and 6 | 190 | 700 | 0.7 | 10 | 23 | 10 | 145 | 330 | |
| 6 | 300 | 700 | 0.3 | 6.0 | 13.5 | 5 | 85 | 200 | |
| 8 and 10 | 290 | 1400 | 1.3 | 13.7 | 30.3 | 20 | 200 | 440 | |
| | | 2800 | 3.4 | 28.3 | 50 | 50 | 410 | 725 | |
| | 490 | 1400 | – | 9.5 | 21.0 | – | 140 | 300 | |
| | | 2800 | 2.3 | 19.5 | 42 | 35 | 280 | 610 | |
| | 735 | 1400 | – | 5.2 | 11.7 | – | 75 | 170 | |
| | | 2800 | – | 10.9 | 23.9 | – | 160 | 350 | |
| 10 | 1150 | 2800 | – | 6.8 | 15 | – | 98 | 217 | |
| | | 2x2800 | – | 13.6 | 30 | – | 197 | 435 | |

 1) Bench range = 0.2 to 0.6 bar for actuator with 700 cm² diaphragm area with 15 mm travel

Table 5 · Dimensions (inch, mm) and weights for Type 3246 Globe Valve with long insulating section and circulation inhibitor

Table 5a · Type 3246 with welding ends and cover plate with collar

| Valve | NPS | | 1/2 | 3/4 | 1 | 1 1/2 | 2 | 3 | 4 | 6 | 8 | 10 | |
|--------------------------------------|-------------------|------------------------|---------------------|---------------------|-------|-------|--------|-----------|--------|------------|--------|--------------------------------------|--|
| Length L | Class 150 and 300 | in | 7.99" ¹⁾ | 8.11" ¹⁾ | 8.27" | 9.88" | 11.26" | 13.27" | 15.51" | 20.0" | 24.02" | 29.61" | |
| | | mm | 203 ¹⁾ | 206 ¹⁾ | 210 | 251 | 286 | 337 | 394 | 508 | 610 | 752 | |
| H4 | Class 150 and 300 | in | 24.02" | | | | | 27.01" | | | 32.99" | | |
| | | mm | 610 | | | | | 686 | | | 838 | | |
| H5 | Class 150 and 300 | in | 28.66" | | | | | 31.10" | 33.27" | 38.90" | 43.86" | 43.86" | |
| | | mm | 728 | | | | | 790 | 845 | 988 | 1114 | 1114 | |
| H8 | in/mm | ≤ 700 | 6.3"/160 | | | | | 9.06"/230 | | 9.06"/230 | | - | |
| | | 1400-60 | - | | | | | - | | 11.02"/280 | | 15.55"/395 SB ≤ 200 ²⁾ | |
| Class 150/300 and pneumatic actuator | 2800 | SB ≤ 200 ²⁾ | - | | | | | - | | - | | 18.9"/480 | |
| | | SB 250 ²⁾ | - | | | | | - | | - | | 24.76"/629 | |
| | | SB ≤ 200 ²⁾ | - | | | | | - | | - | | 18.9"/480 | |
| | | SB 250 ²⁾ | - | | | | | - | | - | | 24.76"/629 | |
| Cover plate | ∅ d | in | 5.98" | | | | | 7.99" | | | 10.0" | | |
| | | mm | 152 | | | | | 203 | | | 254 | | |
| | h | in | 1.57" | | | | | | | | | | |
| | | mm | 40 | | | | | | | | | | |
| Weight, approx. | lbs | | 31 | | 38 | 49 | 84 | 175 | 410 | 948 | 1202 | | |
| | kg | | 14 | | 17 | 22 | 38 | 79 | 186 | 430 | 545 | | |

1) Special length with welding-neck ends

2) SB ≡ Seat bore

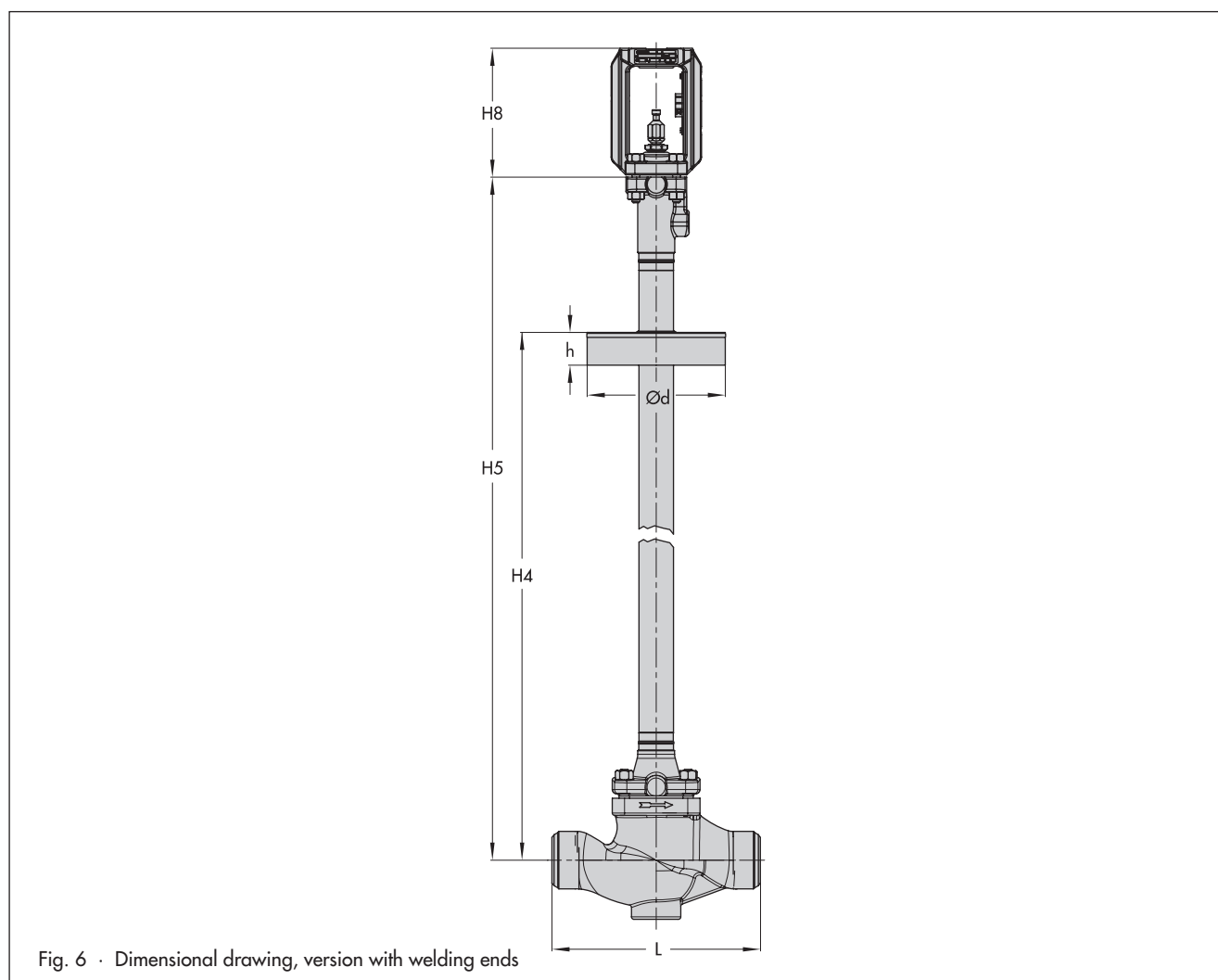

Selecting and sizing control valves

1. Calculate the C_V (K_V) coefficient according to IEC 60 534.
2. Select the valve size and C_V (K_V) from Table 3.
3. Determine the permissible differential pressure Δp according to Tables 4a to 4d.
4. Select the trim material from Table 2.
5. Select the end connections, seat/plug sealing and characteristic from Table 1.

Ordering text

| | |
|--|---|
| Nominal size | NPS |
| Pressure rating | ANSI Class 150 or 300 |
| End connections | Flanges or welding ends |
| Plug | Metal sealing or lapped-in metal |
| Characteristic | Equal percentage, linear or quick opening |
| Pneumatic actuator | Type 3271 or Type 3277 (refer to T 8310-1 EN or T 8310-2 EN) |
| Fail-safe position | Valve CLOSED or OPEN |
| Process medium and density in lb/cu.ft or kg/m ³ and temperature in °C (°F) | |
| Flow rate | lbs/h or kg/h or cu.ft/min or m ³ /h in standard or operating state |
| Pressure | p_1 and p_2 in bar (absolute pressure) at minimum, standard and maximum flow rate |
| Accessories | Positioner and/or limit switch |

Specifications subject to change without notice.

