

Pneumatic Control Valve Type 3254-1 and Type 3254-7 Globe Valve Type 3254

ANSI version

Application

Control valve for process engineering applications with high industrial requirements, especially for high pressures and temperatures

Valve size	NPS 3 to 16
Pressure rating	Class 150 to 2500
Temperatures	-200 to 500 °C (-320 to 930 °F)



Type 3254 Globe Valve with:

- Type 3271 Pneumatic Actuator (Type 3254-1 Control Valve) or
- Type 3277 Pneumatic Actuator (Type 3254-7 Control Valve) for integral positioner attachment

Valve body made of:

- Carbon steel
- Stainless carbon steel
- High-temperature or cold-resisting carbon steel.

Valve plug optionally with:

- Metal sealing
- Soft sealing
- Lapped-in metal
- Balanced for handling high differential pressures
- Additional stem guide in the bottom body flange

The modular design of the control valves allows them to be equipped with various accessories:

Positioners, solenoid valves and other accessories according to IEC 60534-6 and NAMUR recommendation. See Information Sheet T 8350 EN for details.

Version

Standard version with PTFE packing for temperatures from -10 to 220 °C (15 to 430 °F) or with adjustable high-temperature (HT) packing for -10 to 350 °C (15 to 660 °F), valve sizes NPS 3 to 16, Class 150 to 900

- **Type 3254-1** (Fig. 1) · Type 3254 Valve and Type 3271 Actuator with 700 to 2800 cm² effective diaphragm area (refer to Data Sheets T 8310-1 EN and T 8310-2 EN)
- **Type 3254-7** · Type 3254 Valve and Type 3277 Actuator with 350 to 700 cm² effective diaphragm area (refer to T 8310-1 EN)

Other versions

- **Class 1500 and 2500** · On request
- **Welding ends or welding neck ends** acc. to ANSI B16.25
- **Flow divider** · For noise level reduction, see Data Sheet T 8081 EN
- **AC-Trim** · See Data Sheets T 8082 EN and T 8083 EN
- **Extension bonnet or bellows seal** · See Technical data
- **Heating jacket** · Details on request



Fig. 1 · Type 3254-1 Pneumatic Control Valve with Type 3271 Actuator

- **Additional handwheel** · See Data Sheet T 8310-1/-2 EN
- **DIN version** · Nominal size DN 80 to DN 500, nominal pressure PN 16 to 400 (see T 8060 EN)
- **Type 2354-3 Hand-operated Valve** · With Type 3273 Hand-operated Actuator, for valves with max. 30 mm rated travel (see Data Sheet T 8312 EN)
- **Type 3254-2 Electric Control Valve** · Details on request

Principle of operation (Figs. 2 to 4)

The process medium flows through the valve in the direction indicated by the arrow. The valve plug position determines the free area between the valve seat and the plug. The additional stem guide is located in the bottom body flange.

A pressure-balanced plug (Fig. 3) can be used when high pressures or differential pressures act on the valve plug and the force produced by the actuator is insufficient.

Fig. 4 shows the control valve version with a bellows seal. A test connection allows the stainless steel bellows to be monitored.

The control valves can be fitted with Flow Dividers St I (Fig. 4) or St III for a further reduction in the noise level (see Data Sheet T 8081 EN for details).

Fail-safe position

Depending on how the compression springs are arranged in the actuator (see Data Sheet T 8310-1 EN or T 8310-2 EN for details), the control valve has two different fail-safe positions which become effective upon supply air failure:

Actuator stem extends (FA)

The actuator springs close the valve when the supply air fails.

Actuator stem retracts (FE)

The actuator springs open the valve when the supply air fails.

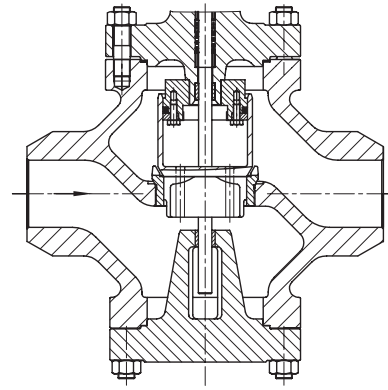

Fig. 3 · Type 3254 Globe Valve with welding ends and balanced valve plug

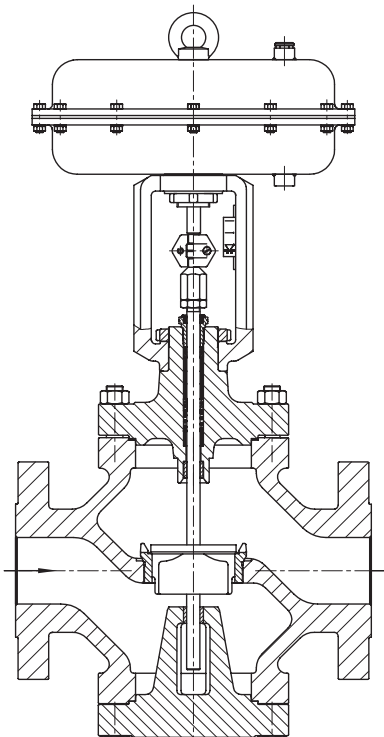

Fig. 2 · Type 3254-1 Control Valve with Type 3271 Pneumatic Actuator

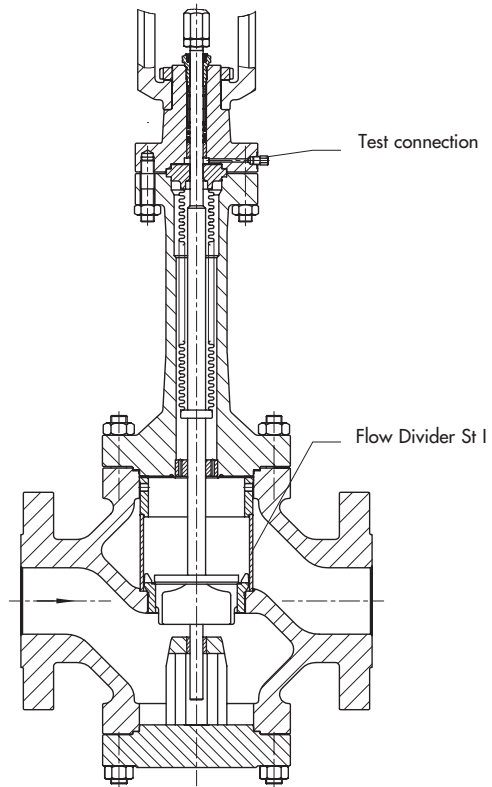

Fig. 4 · Type 3254 Globe Valve with Flow Divider St I and additional bellows seal with test connection

Table 1 · Technical data for Type 3254 Globe Valve

Material		Carbon steel A 216 WCC	Carbon steel A 217 WC6	Stainless carbon steel A 351 CF8M
Valve size ¹⁾	NPS	3 to 16		
Pressure rating ²⁾	Class	150 to 900		
End connections	Flanges	All ANSI versions		
	Welding ends	According to ANSI B16.25		
Seat-plug sealing		Metal sealing · Soft sealing · Lapped-in metal		
Characteristic		Equal percentage · Linear		
Rangeability		50 : 1		
Temperature ranges · Permissible operating pressures according to pressure-temperature diagrams (see Information Sheet T 8000-2 EN)				
Valve body without extension bonnet		-10...220 °C (14...428 °F) · Up to 350 °C (660 °F) with high-temperature packing		
Body with	Extension bonnet	-29... 427 °C (-20...800 °F)	-29... 500 °C (-20...930 °F)	-200... 450 °C (-325...842 °F)
	Bellows seal	-29... 427 °C (-20...800 °F)	-29... 500 °C (-20...930 °F)	-200... 450 °C (-325...842 °F)
Valve plug ³⁾	Standard	Metal sealing	-250 ... 500 °C (-325...930 °F)	
		Soft sealing	-200 ... 220 °C (-325...428 °F)	
	Balanced	PTFE ring	-200 ... 220 °C (-325...428 °F)	
		Graphite ring	220 ... 500 °C (428...930 °F)	
Leakage class according to DIN EN 1349 (ANSI/FCI 20-2-1991)				
Valve plug	Standard	Metal sealing	IV	
		Soft sealing	VI	
		Lapped-in metal	IV-S2 · IV-S1: NPS 4 (DN 100) and larger	
	Balanced	Metal sealing	With PTFE ring: IV · With graphite ring: III	

1) NPS 16 in Class 300 and 600

2) Up to Class 2500 on request

3) Only in conjunction with suitable body material

Table 2 · Materials

Standard version Body and flanges ¹⁾		Carbon steel A 216 WCC	Carbon steel A 217 WC6	Stainless carbon steel A 351 CF8M
Seat and plug ²⁾	Metal sealing	1.4006/1.4008		1.4571/1.4581
	Soft sealing	PTFE with 15 % glass fiber		
	Balanced	PTFE with carbon · Graphite		
Guide bushings		1.4112		2.4610
Packing		PTFE-carbon V-ring packing, spring 1.4310 or high-temperature packing		
Body gasket		Metal		
Extension bonnet ³⁾		A 217 WC6/A 182 F12		A 351 CF8M/A 182 F316
Metal bellows seal				
Intermediate piece ³⁾		A 217 WC6/A 182 F12		A 217 WC6/A 182 F12
Metal bellows		1.4571		
Heating jacket		1.4541		

1) See also pressure-temperature diagrams in Information Sheet T 8000-2 EN
Material for cryogenic service: A 352 LCC

2) Seats and plugs with metal sealing also stellite or plug made of solid Stellite available

3) Depending on the valve bonnet material

Table 3 · C_v coefficients · Version in shaded areas also available with balanced plug

Table 3a · Overview with Flow Divider St I (K_{vsl}) and St III (K_{vslIII})

C _v		75	120	190	290	420	735	1150	1730	2300	2900
K _{vs}		63	100	160	250	360	630	1000	1500	2000	2500
C _{vl}		67	105	170	265	375	650	1040	1560	2080	2600
K _{vsl}		57	90	144	225	320	560	900	1350	1800	2250
C _{vIII}		55	90	140	220	315	560	880	1280	1730	–
K _{vslIII}		47	75	120	190	270	480	750	1100	1500	–
Seat Ø	mm	63	80	100	125	150	200	250	300	350	400
Rated travel	mm	30			60			120			
	in	1.18"			2.36"			4.72"			

Table 3b · Versions without flow divider

C _v		75	120	190	290	420	735	1150	1730	2300	2900
NPS	DN										
3	80	•	•								
4	100	•	•	•							
6	150	•	•	•	•	•					
8	200		•	•	•	•	•				
10	250		•	•	•	•	•	•			
12	300			•	•	•	•	•	•		
16	400					•	•	•	•	•	•

Table 3c · Versions with Flow Divider St I

C _{vl}		67	105	170	265	375	650	1040	1560	2080	2600
NPS	DN										
3	80	•	•								
4	100	•	•	•							
6	150	•	•	•	•	•					
8	200		•	•	•	•	•				
10	250		•	•	•	•	•	•			
12	300			•	•	•	•	•	•		
16	400					•	•	•	•	•	•

Table 3d · Versions with Flow Divider St III

C _{vIII}		55	90	140	220	315	560	880	1280	1730	–
NPS	DN										
4	100	•									
6	150	•	•	•	•						
8	200		•	•	•	•					
10	250		•	•	•	•	•				
12	300			•	•	•	•	•			
16	400					•	•	•	•	•	

Notes on differential pressure tables

The differential pressure tables were prepared under the following conditions:

- Direction of flow: FTO
- Valve plug version with metal sealing or soft sealing
- Version with PTFE packing
- Tables 4a and 4b for unbalanced plug with downstream pressure $p_2 = 0$ bar (psi)
- The leakage rate stated in Table 1 is not exceeded with the maximum differential pressures listed and the previously mentioned conditions
- All pressures mentioned are in bar or psi (gauge)
- The differential pressure stated can be limited by the pressure-temperature diagram

Note on fail-safe position "Valve CLOSED": For actuators with reduced travels, pretensioned spring ranges must be used.

Note: Permissible differential pressures for special versions with soft sealing or lapped-in metal plugs, with metal bellows seal or balanced plug with graphite ring are available on request.

Selection and sizing of control valves

1. Calculate the C_v (K_v) coefficient according to IEC 60534.
2. Select the nominal size and C_v (K_{vs}) coefficient from Tables 3 to 5.
3. Determine the permissible differential pressure Δp from Table 4 or 5.
4. Select the valve body material from Tables 1 and 2 as well as from the pressure-temperature diagrams in the Information Sheet T 8000-2 EN.
5. Select accessories from Tables 1 and 2.

Table 4a · Permissible differential pressures Δp for valves with unbalanced plugs with metal sealing without metal bellows seal; fail-safe position "Valve CLOSED" · Pressures in bar

Values specified in shaded columns apply to standard cases, i.e. application at rated travel · Differential pressures specified in white columns apply to maximum pretensioned springs · Differential pressures in parentheses apply to half travel.

Table 4a · Fail-safe position "Valve CLOSED" (Actuator stem extends)												
Bench range (bar) for actuators (cm ²)		700	0.2...1.0	0.4...1.2 (0.8...1.2)	0.4...2.0	0.8...2.4 (1.6...2.4)	0.6...3.0	1.2...3.6 (2.4...3.6)	1.4...2.3 (1.85...2.3)	2.1...3.3 (2.7...3.3)	2.35...3.8 (3.05...3.8)	2.6...4.3 (3.45...4.3)
		1400					0.5...2.5	1.0...3.0 (2.0...3.0)	1.1...2.4	1.4...2.7 (2.05...2.7)	1.3...2.8	1.7...3.2 (2.45...3.2)
		2800	0.4...1.2 (0.8...1.2)	0.8...2.4 (1.6...2.4)	1.0...3.0 (2.0...3.0)	1.2...3.6 (2.4...3.6)	0.9...1.6	1.1...1.8 (1.25...1.6)	1.0...2.1	1.25...2.35 (1.55...2.1)	1.1...2.6	1.5...3.0 (1.85...2.6)
		2x2800										
Required supply pressure		Upper spring range value + 0.2 bar										
NPS	C _v	Actuator cm ²	Δp when p ₂ = 0 bar									
3 4	75	700	–	6.5	6.5	14.5	10.5	22.6	26.7	40.8	45.9	50.9
		1400	–	(30.7)	–	(63)	–	(79.2)	–	(81.2)	–	(97.4)
6	75	700	–	6.2	6.2	14.3	10.2	22.4	26.4	40.6	45.6	50.7
		1400	–	(30.4)	–	(62.8)	–	(78.9)	–	(81)	–	(97.1)
3 4	120	700	–	–	–	8.8	6.3	13.8	16.4	25.1	28.2	31.4
		1400	–	(18.8)	–	(38.9)	–	(48.9)	–	(50.2)	–	(60.2)
6	120	700	–	–	–	8.6	6.2	13.7	16.2	24.9	28.1	31.2
		1400	–	(18.7)	–	(38.7)	–	(48.8)	–	(50)	–	(60)
8 10	120	700	–	–	–	8.4	5.9	13.4	15.9	24.7	27.8	30.9
		1400	–	(18.4)	–	(38.5)	–	(48.5)	–	(49.7)	–	(59.8)
4	190	700	–	–	–	5.5	–	8.7	10.3	15.9	17.9	19.9
		1400	–	(11.9)	–	(24.7)	–	(31.2)	–	(32)	–	(38.4)
6	190	700	–	–	–	5.4	–	8.6	10.2	15.8	17.8	19.8
		1400	–	(11.8)	–	(24.6)	–	(31)	–	(31.9)	–	(38.3)
8 to 12	190	700	–	–	–	5.2	–	8.4	10	15.6	17.7	19.7
		1400	–	(11.6)	–	(24.5)	–	(30.9)	–	(31.7)	–	(38.1)
6	290	1400	–	–	–	7.4	4.4	9.5	10.5	13.6	12.6	16.7
		2800	(15.6)	(32.1)	(40.3)	(48.5)	–	(24.9)	–	(31)	–	(37.2)
8 to 12	290	1400	–	–	–	7.3	4.2	9.4	10.4	13.5	12.5	16.6
		2800	(15.5)	(32)	(40.2)	(48.4)	–	(24.7)	–	(30.9)	–	(37.1)
		2x2800	(33)	(64)	(80.2)	(96.8)	–	(49.4)	–	(61.8)	–	(74.2)
6	420	1400	–	–	–	5.1	–	6.5	7.2	9.4	8.6	11.5
		2800	(10.8)	(22.2)	(27.9)	(33.6)	–	(17.2)	–	(21.5)	–	(25.7)
8 to 16	420	1400	–	–	–	5	–	6.4	7.1	9.3	8.6	11.4
		2800	(10.7)	(22.1)	(27.8)	(33.5)	–	(17.1)	–	(21.4)	–	(25.7)
		2x2800	(21.4)	(44.2)	(55.6)	(67)	–	(34.2)	–	(42.8)	–	(51.4)
8 to 16	735	1400	–	–	–	–	–	–	–	5.1	4.7	6.3
		2800	(5.9)	(12.3)	(15.5)	(18.8)	–	(9.5)	–	(11.9)	–	(14.3)
		2x2800	(11.8)	(24.6)	(31)	(37.6)	–	(19)	–	(23.8)	–	(28.6)
10 to 16	1150	2800	–	–	4.8	5.8	4.2	5.3	4.8	6	5.3	7.3
		2x2800	–	7.4	9.6	11.6	8.4	10.6	9.6	12	10.6	14.6
12 16	1730	2800	–	–	–	4	–	–	–	4.1	–	5
		2x2800	–	5	6.6	8	5.8	7.2	6.6	8.2	7.2	10
16	2300	2800	–	–	–	–	–	–	–	–	–	–
		2x2800	–	–	4.8	5.8	4.2	5.2	4.8	6	5.2	7.4
16	2900	2800	–	–	–	–	–	–	–	–	–	–
		2x2800	–	–	–	4.4	–	4	–	4.6	4	5.6

Table 4b · Permissible differential pressures Δp for valves with unbalanced plugs with metal sealing without metal bellows seal; fail-safe position "Valve CLOSED" · Pressures in psi

Values specified in shaded columns apply to standard cases, i.e. application at rated travel · Differential pressures specified in white columns apply to maximum pretensioned springs · Differential pressures in parentheses apply to half travel.

Table 4b · Fail-safe position "Valve CLOSED" (Actuator stem extends)												
Bench range (psi) for actuators (cm ²)	700		3...15	6...18 (12...18)	6...30	12...36 (23...36)	9...45	18...52 (35...52)	20...34 (27...34)	30...48 (39...48)	35...55 (44...55)	36...62 (50...62)
	1400						7...36	15...45 (30...45)	16...36	20...39 (30...39)	19...21	25...46 (36...46)
	2800		6...18 (12...18)	12...36 (23...36)	15...45 (30...45)	18...52 (35...52)	12...23	16...26 (18...34)	15...30	18...34 (22...30)	17...36	22...45 (27...36)
	2x2800											
Required supply pressure			Upper spring range value + 3 psi									
NPS	Cv	Actuator cm ²	Δp when p ₂ = 0 psi									
3 4	75	700	-	94	94	210	152	327	387	591	46	738
		1400	-	(445)	-	(913)	-	(1148)	-	(1177)	-	(1412)
6	75	700	-	89.9	89	207	147	324	382	588	661	735
		1400	-	(440)	-	(910.6)	-	(1144)	-	(1174)	-	(1408)
3 4	120	700	-	-	-	127	91	200	237	364	409	455.3
		1400	-	(272)	-	(564)	-	(709)	-	(727)	-	(873)
6	120	700	-	-	-	124	85.5	1972	1655	361	407	452
		1400	-	(271)	-	(561)	-	(707)	-	(725)	-	(870)
8 10	120	700	-	-	-	121	85	194	230	358	403	448
		1400	-	(266)	-	(558)	-	(703)	-	(720)	-	(867)
4	190	700	-	-	-	79	-	126	149	230	259	288
		1400	-	(172)	-	(358)	-	(452)	-	(464)	-	(556)
6	190	700	-	-	-	78	-	124	148	229	258	287
		1400	-	(171)	-	(356)	-	(449)	-	(462)	-	(555)
8 to 12	190	700	-	-	-	75	-	121	145	226	256	285
		1400	-	(168)	-	(355)	-	(448)	-	(459)	-	(552)
6	290	1400	-	-	-	107	63	137	152	197	182	242
		2800	(226)	(465)	(584)	(703)	-	(361)	-	(449)	-	(539)
8 to 12	290	1400	-	-	-	105	61	136	150	195	181	240
		2800	(224)	(464)	(583)	(707)	-	(358)	-	(448)	-	(537)
		2x2800	(478)	(928)	(1163)	(1403)	-	(716)	-	(896)	-	(1075)
6	420	1400	-	-	-	73	-	94	104	136	124	166
		2800	(156)	(322)	(404)	(487)	-	(249)	-	(311)	-	(372)
8 to 16	420	1400	-	-	-	72	-	92	103	134	124	165
		2800	(155)	(320)	(403)	(485)	-	(248)	-	(310)	-	(372)
		2x2800	(310)	(461)	(806)	(971)	-	(495)	-	(620)	-	(745)
8 to 16	735	1400	-	-	-	-	-	-	-	73	68	91
		2800	(85)	(178)	(224)	(272)	-	(137)	-	(172)	-	(207)
		2x2800	(171)	(356)	(449)	(545)	-	(275)	-	(345)	-	(414)
10 to 16	1150	2800	-	-	69	84	61	76	69	87	76	105
		2x2800	-	107	139	168	121	153	139	174	153	211
12 16	1730	2800	-	-	-	58	-	-	-	59	-	72
		2x2800	-	72	95	116	84	104	95	118	104	145
16	2300	2800	-	-	-	-	-	-	-	-	-	-
		2x2800	-	-	69	84	61	75	69	87	75	107
16	2900	2800	-	-	-	-	-	-	-	-	-	-
		2x2800	-	-	-	63	-	58	-	66	58	81

Table 5a · Permissible differential pressures Δp for valves with balanced plugs with PTFE ring and metal sealing, without metal bellows seal · Pressures in bar

Values specified in shaded columns apply to standard cases, i.e. application at rated travel · Differential pressures specified in white columns apply to maximum pretensioned springs · Differential pressures in parentheses apply to half travel.

Fail-safe position "Valve CLOSED" (Actuator stem extends)									"Valve OPEN" (stem retracts)		
Bench range (bar) for actuators (cm ²)	700	0.4...2.0	0.8...2.4	-	-	0.6...3.0	1.2...3.6	0.4...2.0 (0.4...1.2)			
	1400		0.8...2.4 (1.6...2.4)	0.5...2.7	1.0...3.0 (2.0...3.0)	-	-				
	2800					0.6...3.0	1.2...3.6 (2.4...3.6)				
	2x2800										
Required supply pressure		Upper spring range value + 0.2 bar							2.4	4.0	6.0
NPS	C _v	Actuator cm ²	Δp when p ₂ = 0 bar								
3 4	75	700	57.4	155	-	-	106	252	57.4	400	400
		1400	-	(400)	-	(400)	-	-	(400)	(400)	(400)
3 4	120	700	48.1	144	-	-	96.9	243	48.1	400	400
		1400	-	(400)	-	(400)	-	-	(400)	(400)	(400)
6	120	700	18.4	58.3	-	-	38.4	98.3	18.4	178	378
		1400	-	(297)	-	(378)	-	-	(218)	(400)	(400)
4	190	700	37.2	135	-	-	85.9	232	37.2	400	400
		1400	-	(400)	-	(400)	-	-	(400)	(400)	(400)
6	190	700	13.9	53.9	-	-	33.9	93.8	13.9	173	373
		1400	-	(293)	-	(373)	-	-	(213)	(400)	(400)
8 to 12	190	700	4.6	20.2	-	-	12.4	35.8	4.6	67	145
		1400	-	(113)	-	(145)	-	-	(82.6)	(207)	(363)
6	290	1400	48.3	128	68.2	168	-	-	48.3	367	400
		2800	-	(236)	-	(298)	-	(361)	(400)	(400)	(400)
8 to 10	290	1400	18	49.2	25.8	64.8	-	-	18	143	298
		2800	-	(236)	-	(298)	-	(361)	(174)	(400)	(400)
6	420	1400	42.6	122	62.6	162	-	-	42.7	362	400
		2800	-	(400)	-	(400)	-	(400)	(400)	(400)	(400)
8 to 16	420	1400	15.8	47	23.6	62.6	-	-	15.8	140	296
		2800	-	(234)	-	(296)	-	(359)	(172)	(400)	(400)
		2x2800	-	(400)	-	(400)	-	(400)	(344)	(400)	(400)
8 to 16	735	1400	11.4	42.6	19.2	58.2	-	-	11.4	136	292
		2800	-	(230)	-	(292)	-	(355)	(167)	(400)	(400)
		2x2800	-	(400)	-	(400)	-	(400)	(334)	(400)	(400)
10 to 16	1150	2800	38.3	100	53.9	132	69.4	163	38.3	288	400
		2x2800	76.6	200	107.8	264	138.8	326	76.6	400	400
12 16	1730	2800	33.9	96.3	49.5	127	65.1	158	33.9	283	400
		2x2800	67.8	192	99	254	130	316	67.8	400	400
16	2300	2800	29.5	91.9	45.1	123	60.7	154	29.5	279	400
		2x2800	59	184	90.2	246	121	308	59	400	400
16	2900	2800	25.1	87.5	40.7	118	56.3	150	25.1	274	400
		2x2800	50.2	175	81.4	236	112	300	50.2	400	400

Table 5b · Permissible differential pressures Δp for valves with balanced plugs with PTFE ring and metal sealing, without metal bellows seal · Pressures in psi

Values specified in shaded columns apply to standard cases, i.e. application at rated travel · Differential pressures specified in white columns apply to maximum pretensioned springs · Differential pressures in parentheses apply to half travel.

Fail-safe position "Valve CLOSED" (Actuator stem extends)									"Valve OPEN" (stem retracts)		
Bench range (psi) for actuators (cm ²)	700	6...30	12...36	-	-	9...45	18...52	6...30 (6...18)			
	1400		12...36 (23...36)	7...36	15...45 (30...45)	-	-				
	2800					9...45	18...52 (35...52)				
	2x2800										
Required supply pressure		Upper spring range value + 3 psi							36	60	90
NPS	C _v	Actuator cm ²	Δp when p ₂ = 0 psi								
3 4	75	700	832	2247	-	-	1537	3654	832	5800	5800
		1400	-	(5800)	-	(5800)	-	-	(5800)	(5800)	(5800)
3 4	120	700	697	209	-	-	1405	3524	697	5800	5800
		1400	-	(5800)	-	(5800)	-	-	(5800)	(5800)	(5800)
6	120	700	267	845	-	-	557	1425	267	2581	5481
		1400	-	(4307)	-	(5481)	-	-	(3161)	(5800)	(5800)
4	190	700	539	1958	-	-	1246	3364	539	5800	5800
		1400	-	(5800)	-	(5800)	-	-	(5800)	(5800)	(5800)
6	190	700	202	782	-	-	492	1360	202	2509	5409
		1400	-	(4249)	-	(5409)	-	-	(3089)	(5800)	(5800)
8 to 12	190	700	67	293	-	-	180	519	67	972	2103
		1400	-	(1639)	-	(2103)	-	-	(1198)	(3002)	(5264)
6	290	1400	700	1856	989	2436	-	-	700	5322	5800
		2800	-	(3422)	-	(4321)	-	(5235)	(5800)	(5800)	(5800)
8 10	290	1400	261	713	374	940	-	-	261	2074	4321
		2800	-	(3422)	-	(4321)	-	(5235)	(2523)	(5800)	(5800)
6	420	1400	618	1769	908	2349	-	-	618	5349	5800
		2800	-	(5800)	-	(5800)	-	(5800)	(5800)	(5800)	(5800)
8 to 16	420	1400	229	682	342	908	-	-	229	2030	4392
		2800	-	(3393)	-	(4292)	-	(5206)	(2494)	(5800)	(5800)
		2x2800	-	(5800)	-	(5800)	-	(5800)	(4988)	(5800)	(5800)
8 to 16	735	1400	165	618	278	844	-	-	165	1972	4234
		2800	-	(3335)	-	(4234)	-	(5148)	(2422)	(5800)	(5800)
		2x2800	-	(5800)	-	(5800)	-	(5800)	(4843)	(5800)	(5800)
10 to 16	1150	2800	555	1450	782	1914	1006	2364	555	4176	5800
		2x2800	1111	2900	1563	3828	2013	4727	1111	5800	5800
12 16	1730	2800	492	1396	718	1842	944	2291	492	4104	5800
		2x2800	983	2784	1436	3683	1885	4582	983	5800	5800
16	2300	2800	428	1333	654	1784	880	2233	428	4046	5800
		2x2800	856	2668	1308	3567	1755	4466	856	5800	5800
16	2900	2800	364	1269	590	1711	816	2175	364	3973	5800
		2x2800	728	2538	1180	3422	1624	4350	728	5800	5800

Table 6 · Permissible differential pressures Δp for valves with unbalanced plugs with metal sealing, without metal bellows seal; fail-safe position "Valve OPEN" (stem retracts) · Pressures in bar and psi

			Table 6a · Pressures in bar				Table 6b · Pressures in psi				
Bench range (bar/psi) for actuators (cm ²)			0.2...1.0 (0.2...0.6)				3...15 (3...9)				
			700								
			1400								
			2800								
2x2800											
Required supply pressure			1.4	2.4	4.0	6.0	18	36	60	90	
NPS	C _v	Actuator cm ²	Δp when p ₂ = 0 bar				Δp when p ₂ = 0 psi				
3 4	75	700	6.5	26.7	59	99.4	94	387	855	1442	
		1400	(30.7)	(71)	(136)	–	(445)	(1029)	(1972)	–	
6	75	700	6.2	26.4	58.7	99.2	90	382	851	1438	
		1400	(30.6)	(71)	(136)	–	(443)	(1029)	(1972)	–	
3 4	120	700	–	16.3	36.4	61.5	–	236	527	891	
		1400	(18.8)	(43.9)	(84)	(134)	(272)	(636)	(1218)	(1943)	
6	120	700	–	16.2	36.2	61.3	–	234	524	888	
		1400	(18.7)	(43.7)	(83.8)	(134)	(271)	(633)	(1215)	(1943)	
8 10	120	700	–	15.9	35	61.1	–	230	507	886	
		1400	(18.4)	(43.5)	(83)	(134)	(266)	(630)	(1348)	(1943)	
4	190	700	–	10.2	23.1	39.1	–	148	335	567	
		1400	(11.8)	(27.8)	(53.5)	(85.6)	(171)	(403)	(775)	(1241)	
6	190	1400	–	10.2	23	39.1	–	148	333	567	
		2800	(11.8)	(27.8)	(53.5)	(85.6)	(171)	(403)	(775)	(1241)	
8 to 12	190	1400	–	10.1	22.9	38.9	–	146	332	564	
		2800	(11.6)	(27.7)	(53.4)	(85.5)	(168)	(401)	(774)	(1239)	
6	290	1400	–	13.6	30	50.6	–	197	435	733	
		2800	(15.6)	(36.2)	(69)	–	(226)	(525)	(1000)	–	
8 to 12	290	1400	–	13.5	29.9	50.4	–	195	433	730	
		2800	(15.5)	(36.1)	(68.9)	–	(224)	(523)	(999)	–	
		2x2800	(31)	(72)	(138)	–	(449)	(1044)	(2001)	–	
6	420	1400	–	9.4	20.8	35	–	136	301	507	
		2800	(10.8)	(25)	(47.8)	–	(156)	(362)	(693)	–	
8 to 16	420	1400	–	9.3	20.7	34.9	–	134	300	506	
		2800	(10.7)	(25)	(47.8)	–	(155)	(362)	(693)	–	
		2x2800	(21.4)	(50)	(95.6)	–	(310)	(725)	(1386)	–	
8 to 16	735	1400	–	5.1	11.5	19.6	–	74	166	284	
		2800	(5.9)	(13.9)	(26.8)	(42.8)	(85)	(201)	(388)	(620)	
		2x2800	(11.8)	(27.8)	(53.6)	–	(171)	(403)	(777)	–	
10 to 16	1150	2800	–	6.8	15	25.3	–	98	217	266	
		2x2800	–	13.6	30	50.6	–	197	435	733	
12 16	1730	2800	–	4.7	10.4	17.5	–	26	150	253	
		2x2800	–	9.4	20.8	35	–	136	301	407	
16	2300	2800	–	–	7.6	12.8	–	–	110	185	
		2x2800	–	6.8	15.2	25.6	–	98	220	271	
16	2900	2800	–	–	5.8	9.8	–	–	84	142	
		2x2800	–	5.2	11.6	19.6	–	75	168	284	

Table 7 · Dimensions for Type 3254-1 and Type 3254-7 Pneumatic Control Valve in standard version

Valve		NPS	3	4	6	8	10	12	16	
Length L	Class 150	mm	298	352	451	543	673	736	1016	
		inch	11.73	13.83	17.75	21.37	26.49	28.97	40.00	
	Class 300	mm	318	368	473	568	708	775	1057	
		inch	12.52	14.49	18.62	22.36	27.87	30.51	41.61	
	Class 600	mm	337	394	508	609	752	819	1108	
		inch	13.26	15.51	20	23.97	29.6	32.24	43.62	
Class 900	mm	381	457	609	737	838	965	-		
	inch	15	17.99	23.97	29.01	32.99	37.99			
H1 for actuator	700 cm ²	Class 150/600	mm	462	482	732	805	-		
			inch	18.18	18.97	29.01	31.69			
		Class 900	mm	462	482	732	805	-		
			inch	18.18	18.97	29.01	31.69			
	1400 cm ²	Class 150/600	mm	517	537	732	805	860	-	
			inch	20.35	21.14	29.01	31.69	33.85		
		Class 900	mm	517	537	732	805	860	-	
			inch	20.35	21.14	29.01	31.69	33.85		
	2800 cm ²	Class 150/600	mm	702	722	817	890	1094	1290	1290
			inch	27.63	28.42	32.16	35.04	43.07	50.78	50.78
		Class 900	mm	702	722	817	890	1094	1290	-
			inch	27.63	28.42	32.16	35.04	43.07	50.78	
H2	Class 150	mm	175	207	288	390	410	480	560	
		inch	8.69	8.15	11.33	15.35	16.14	18.89	22.04	
	Class 300/600	mm	222	249	338	390	410	480	650	
		inch	8.74	9.8	13.3	15.35	16.14	18.89	25.59	
	Class 900	mm	222	249	338	390	410	480	-	
		inch	8.74	9.8	13.3	15.35	16.14	18.89		

Actuator	cm ²	700	1400	2800	2 x 2800
Diaphragm Ø D	mm	390	530	770	
	inch	15.35	20.86	30.3	
H	mm	200	287	620	1130
	inch	7.87	11.3	24.41	44.49
H3 ¹⁾	mm	190	610	650	
	inch	7.48	24	25.6	
Thread		M 30 x 1.5	M 60 x 1.5	M 100 x 2	
a (with Type 3271 Actuator)		G 3/8 (3/8 NPT)	G 3/4 (3/4 NPT)	G 1 (1 NPT)	
a2 (with Type 3277 Actuator)		G 3/8 (3/8 NPT)	-		

¹⁾ Minimum clearance for removing actuator

Table 8 · Weights for Type 3254-1 and Type 3254-7 Pneumatic Control Valve in standard version

Valve		NPS	3	4	6	8	10	12	16
Valve without actuator (approx.)	Class 150/300	kg	On request	150	380	380	On request		
		lbs		331	838	838			
	Class 600	kg		150	380	580			
		lbs		331	838	1278			
	Class 900	kg		175	420	700			
		lbs		386	926	1543			

Actuator		cm ²	700	1400	2800	2 x 2800	
Type 3271 (approx.)	Without handwheel	kg	22	70	450	950	
		lbs	48.5	154.5	992	2095	
	With handwheel	kg	27	Only with side-mounted handwheel, see T 8310-2 EN			
		lbs	59.5				
Type 3277 (approx.)	Without handwheel	kg	26	-			
		lbs	57.6				
	With handwheel	kg	31				
		lbs	68.5				

Pneumatic actuators

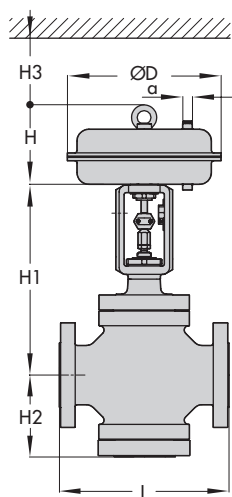

Type 3254-1

Type 3271

Type 3277

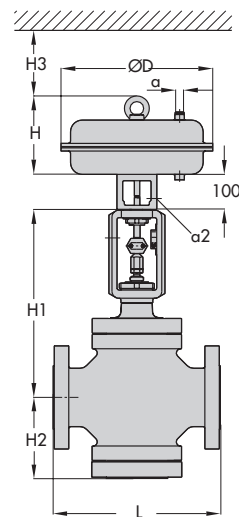

Type 3254-7

Table 9 · Dimensions and weights for Type 3254 Valve in standard version with extension bonnet · Without actuator

Valve		NPS	3	4	6	8	10	12	16
Class 150 to 600	700 cm ²	mm	732	752	1083	1365	-		
		inch	28.82	29.6	42.64	53.74			
H4 for actuator	1400 cm ²	mm	787	807	1083	1365	1485	-	
		inch	30.98	31.77	42.64	53.74	58.46		
	2800 cm ²	mm	972	992	1168	1450	1719	1810	1870
		inch	38.26	39.05	45.98	57.08	67.67	71.26	73.62
Class 900	700 cm ²	mm	732	752	1083	1365	-		
		inch	28.82	29.6	42.64	53.74			
H4 for actuator	1400 cm ²	mm	787	807	1083	1365	1485	-	
		inch	30.98	31.77	42.64	53.74	58.46		
	2800 cm ²	mm	972	992	1168	1450	1719	-	
		inch	38.26	39.05	45.98	57.08	67.67		
Weight without actuator for	Class 150/300	kg	On request	169	400	480	On request		
		lbs		373	882	1058			
	Class 600	kg		169	400	680			
		lbs		373	882	1500			
	Class 900	kg		195	440	800			
		lbs		430	970	1764			

Table 10 · Dimensions and weights for Type 3254 Valve in standard version with bellows seal · Without actuator

Valve		NPS	3	4	6	8	10	12	16
Class 150	700 cm ²	mm	841	841	1139	1455	-		
		inch	33.1	33.1	44.85	57.3			
H4 for actuator	1400 cm ²	mm	896	896	1139	1455	1905	-	
		inch	35.3	35.3	44.85	57.3	75		
	2800 cm ²	mm	1081	1081	1224	1540	2139	2150	2180
		inch	42.56	42.56	48.2	60.63	84.21	84.64	85.82
Class 300/600	700 cm ²	mm	841	841	1271	1855	-		
		inch	33.1	33.1	50.04	73.03			
H4 for actuator	1400 cm ²	mm	896	896	1271	1855	-		
		inch	35.3	35.3	50.04	73.03			
	2800 cm ²	mm	1081	1081	1356	1940			
		inch	42.56	42.56	53.4	76.4			
Class 900	700 cm ²	mm	841	841	1271	1990	-		
		inch	33.1	33.1	50.04	78.35			
H4 for actuator	1400 cm ²	mm	896	896	1271	1990	-		
		inch	35.27	35.27	50.04	78.35			
	2800 cm ²	mm	1081	1081	1356	2075			
		inch	42.56	42.56	53.4	81.7			
Weight without actuator for	Class 150/300	kg	On request	169	400	480	On request		
		lbs		373	882	1058			
	Class 600	kg		169	400	680			
		lbs		373	882	1500			
	Class 900	kg		195	440	800			
		lbs		430	970	1764			

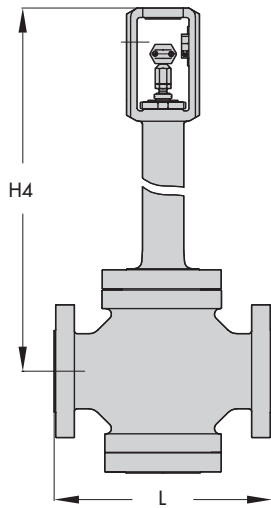

Type 3254 with bellows seal or extension bonnet

The following details are required on ordering

Valve size	NPS
Pressure rating	PN
Body material	According to Table 2
End connection	Flanges/welding ends
Plug	Standard/balanced Soft sealing, metal sealing or lapped-in metal
Characteristic	Equal percentage or linear
Actuator	Type 3271 or Type 3277 (see T 8310-1 EN or T 8310-2 EN)
Fail-safe position	Valve CLOSED or valve OPEN
Process medium	Density in lb/cu.ft or kg/m ³ and temperature in °C
Flow rate	lbs/h or kg/h or cu.ft/min or m ³ /h under normal or operating condition
Pressure	p ₁ and p ₂ in bar (psi) (absolute pressure p _{abs}), both with minimum, normal and maximum flow rate
Accessories	Positioner and/or limit switches

Specifications subject to change without notice.

