

Series 240

Type 3248-1 and Type 3248-7 Pneumatic Control Valves Type 3248 Cryogenic Valve



DIN version

Application

Globe or angle valve for cryogenic applications · Easy to service due to top-entry design

Nominal size	DN 25 to 150
Nominal pressure	PN 16 to 100
Temperature range	-273 to +65 °C



The Type 3248 Cryogenic Valve is specially designed to meet the requirements of cryogenic applications.

- Standard metal bellows to meet strict emission requirements
- Minimized heat leak thanks to the use of a bellows seal and a cryogenic extension bonnet
- Globe or angle-style valve body
- Installation in vacuum-insulated pipelines, air separation plants, and peripheral plants made possible by a cover plate on the cryogenic extension bonnet
- Valve maintenance possible without removing it from the pipeline
- Top entry through the cryogenic extension bonnet allows easy access to the seat, plug, and bellows after removal of the actuator
- The K_{VS} coefficients can be modified in wide ranges by replacing the seat and valve plug

Versions

Standard version · Temperature range from -196 to +65 °C
Stem sealed by metal bellows and self-adjusting V-ring packing made of pure PTFE or PTFE/carbon

- **Type 3248-1** · With Type 3271 Pneumatic Actuator, 175 to 2800 cm² effective diaphragm area
- **Type 3248-7** · With Type 3277 Pneumatic Actuator for integral positioner attachment, 175 to 750 cm² effective diaphragm area

Further versions

- Temperature range from -196 down to -273 °C
- Temperatures above 65 °C · On request
- Free of oil and grease for oxygen service
- Version for ultrapure gas
- Pipe jacketing for installation in vacuum-insulated plant components
- Pneumatic actuator with additional handwheel
- Cryogenic valves according to ANSI standard in NPS 1 to 6, Class 150 to 600 · See Data Sheet ▶ T 8093-1

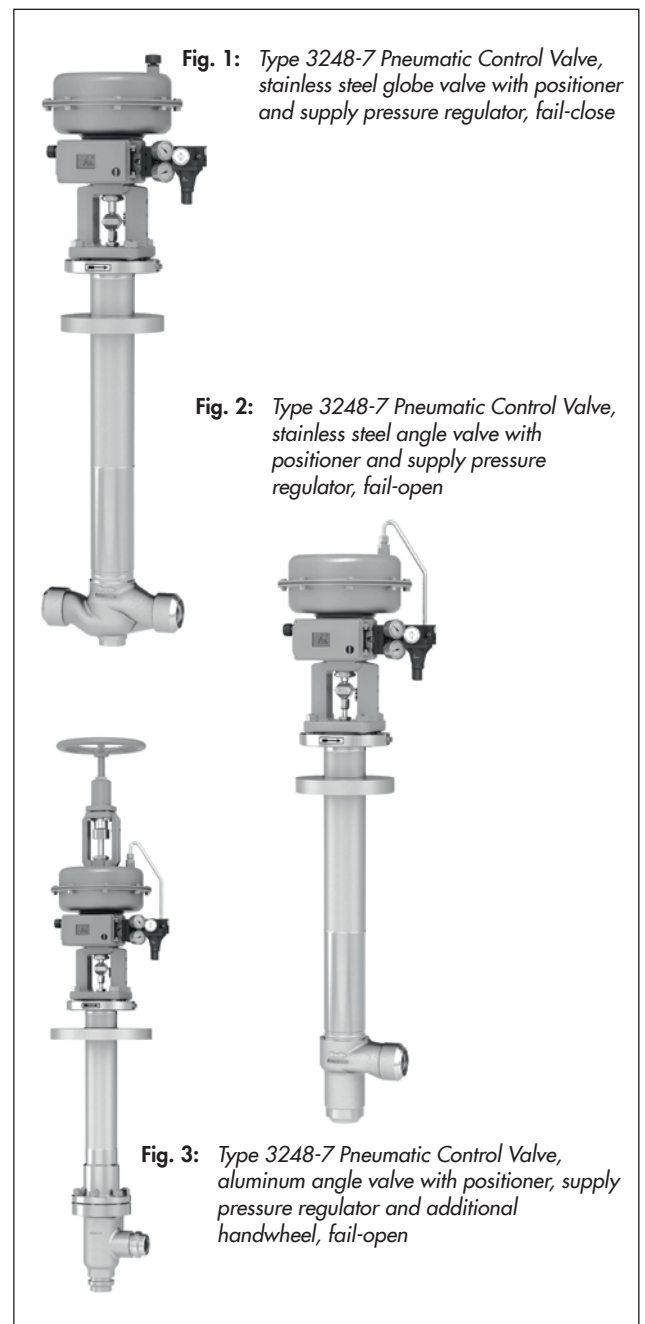

Principle of operation

The medium flows through the cryogenic valve in the direction indicated by the arrow. The position of the valve plug (5) in relation to the seat (4) determines the flow rate.

The metal bellows seal (37) guarantees that the medium has no direct contact with the V-ring packing (15). The packing to seal the stem to the atmosphere is self-adjusting.

The stem seal can be checked at any time for leakage by removing the screw plug at the test connection (42).

Installation

We recommend mounting the valve at an angle between 15° and 25° to the horizontal plane. Please contact SAMSON for smaller mounting angles as additional measures are required in this case. Avoid attaching the bracket or support in the area around bellows nut (41) (refer to the Mounting and Operating Instructions ► EB 8093).

The medium must flow through the valve in the direction indicated by the arrow on the valve body (1).

Fail-safe position

Depending on how the springs are arranged in the pneumatic actuator (see Data Sheet ► T 8310-1), the valve has two different fail-safe positions effective upon air supply failure:

- **Actuator stem extends (FA)**
When the air supply fails, the spring force moves the stem downward causing the valve to close.
- **Actuator stem retracts (FE)**
When the air supply fails, the spring force moves the stem upwards causing the valve to open.

Differential pressures

Permissible differential pressures are listed in Information Sheet ► T 8000-4:

- Valves in PN 16 to 40 according to Tables 1.1 to 1.3
- PN 63 to 100 according to Tables 2.1 to 2.3

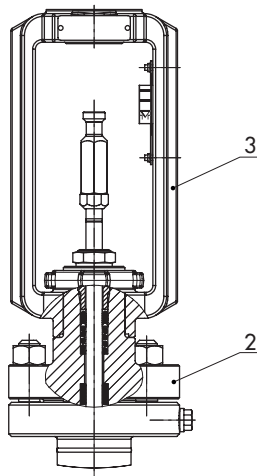

Fig. 4: Bonnet and yoke for PN 100

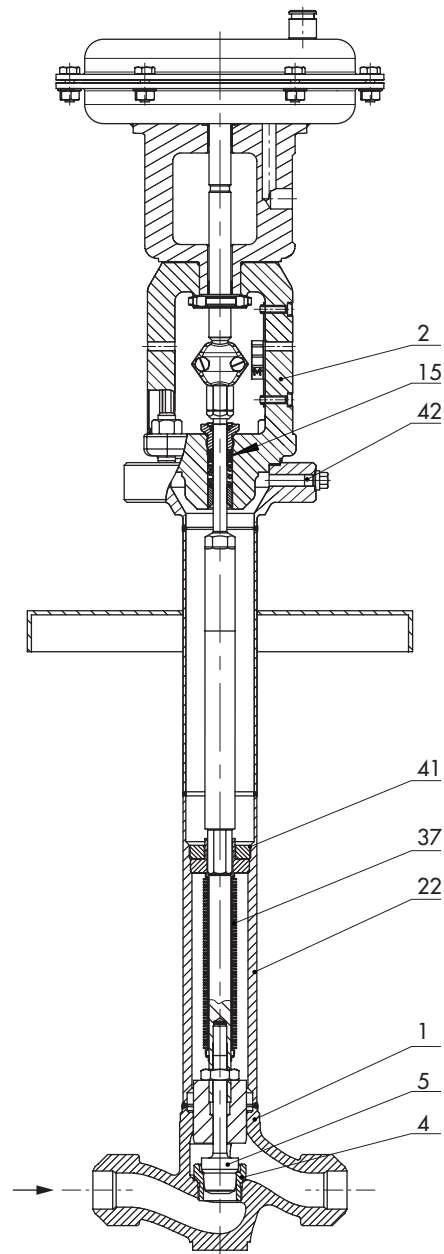

Fig. 5: Type 3248-7 (globe valve), PN 40

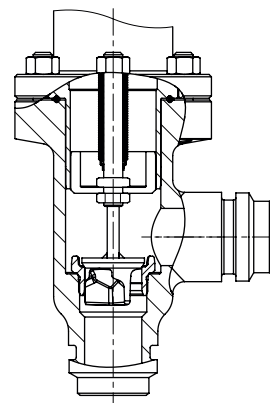

Fig. 6: Type 3248 Angle Valve with aluminum body, PN 40

Legend for Fig. 4 and Fig. 5

1	Body	15	V-ring packing
2	Bonnet	22	Bellows seal
3	Yoke	37	Plug stem with bellows
4	Seat	41	Bellows nut
5	Plug	42	Test connection

Table 1: Technical data for Type 3248 Cryogenic Valve

Version	DIN EN		
Body style	Globe valve	Angle valve	
Body material	Steel	Steel	Aluminum
Nominal size	DN 25 to 150	DN 25 to 150	DN 25 to 150
Nominal pressure	PN 16 to 100	PN 16 to 100	PN 16 to 40
End connections for globe and angle valves	Welding ends according to EN 12627	Welding ends according to EN 12627	Welding ends according to EN ISO 9692
Seat-plug seal	Metal seal · Soft seal · High-performance metal seal		
Characteristic	Equal percentage or linear		
Rangeability	50:1 up to DN 50 30:1 for DN 80 to 150		
Temperature range	-196 to +65 °C · Down to -273 °C on request		
Leakage class according to IEC 60534-4	Metal seal: IV · Soft seal: VI · High-performance metal seal: V		
Compliance			

Table 2: Material

Valve	Globe valve	Angle valve	
Valve body	1.4308	1.4308	EN AW-5083
Seat ¹⁾	CrNiMo steel	CrNiMo steel	
Plug ¹⁾	Metal seal	CrNiMo steel	
	Soft seal	Seal ring made of PTFE with glass fiber	
V-ring packing	PTFE with carbon or pure PTFE		
Cryogenic extension bonnet, metal bellows, bushings, plug stem	CrNiMo steel		

¹⁾ Seats and plugs without soft seal also with Stellite® facing · Plug up to seat bore 48 made of solid Stellite® available.

Table 3: K_{VS} coefficients
Table 3.1: Overview

K_{VS}	0.1 to 0.25	0.4 to 1	1.6 to 4	6.3 to 10	16	25	40	60	80	63	100	160	260
Seat Ø mm	3	6	12	24	31	38	48	63	80	63	80	100	130
Travel mm	15	15	15	15	15	15	15	15	15	30	30	30	30

Table 3.2: Nominal sizes and associated K_{VS} coefficients

K_{VS}	0.1 0.16 0.25	0.4 0.63 1	1.6 2.5 4	6.3 10	16	25	40	60	80	63	100	160	260
DN													
25	•	•	•	•									
40		•	•	•	•	•							
50		•	•	•	•	•	•						
80						•	•	•	•				
100										•	•	•	
150										•	•	•	•

Table 4: Dimensions in mm and weights in kg for Type 3248 Globe Valve**i Note**

Height H7 is the minimum clearance for service work. The actuator dimensions and the height H3 in Table 6.1 must also be observed. The largest value applies.

Height H1 and the specified weights are reference values. The exact dimensions and weights depend on various factors, e.g. actuator size and overall height.

Table 4.1: Stainless steel valve body, PN 16 to 40 according to EN (Fig. 7, Fig. 8)

Valve	DN	25	40	50	80	100	150
L	mm	210	251	286	337	394	508
H1	mm	854	864	864	1052	1147.5	1188.5
H2	mm	44	71	71	93	111	174
H4 ¹⁾	mm	600	600	600	700	800	800
H5	mm	708	714	714	824	933.5	974.5
H7	mm	1050	900	900	900	1100	1100
Ød	mm	282	282	282	282	282	282
Welding ends/pipe connection ¹⁾		Ø33.7 x 2.3	Ø48.3 x 2.6	Ø60.3 x 3.2	Ø88.9 x 4	Ø114.3 x 5	Ø168.3 x 5.6
Weight without actuator	kg	17	30	30	55	96	131

¹⁾ Deviating dimensions on request

Table 4.2: Stainless steel valve body, PN 63 to 100 according to EN (Fig. 7, Fig. 8)

Valve	DN	25	40	50	80	100	150
L	mm	210	251	286	337	394	508
H1	mm	822	817	817	832	984	1298
H2	mm	44	71	71	93	111	174
H4 ¹⁾	mm	600	600	600	600	650	800
H5	mm	734	734	734	734	786	923
H7	mm	1050	900	900	900	1100	1100
Ød	mm	282	282	282	282	282	282
Welding ends/pipe connection ¹⁾		Ø33.7 x 3.2	Ø48.3 x 3.6	Ø60.3 x 4	Ø88.9 x 5.6	Ø114.3 x 6.3	Ø168.3 x 7.1
Weight without actuator	kg	19	35	35	80	108	190

¹⁾ Deviating dimensions on request

Dimensional drawings

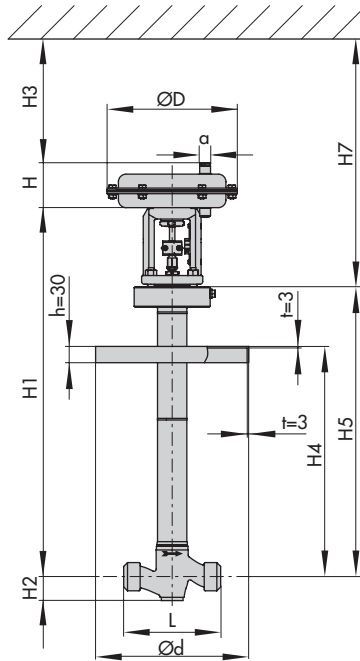

Fig. 7: Type 3248-1 Globe Valve with stainless steel valve body

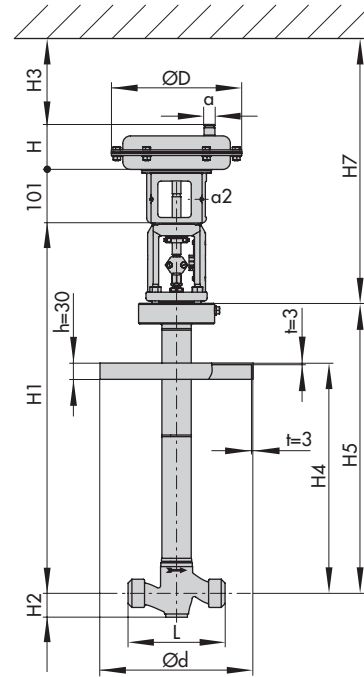

Fig. 8: Type 3248-7 Globe Valve with stainless steel valve body

Table 5: Dimensions in mm and weights in kg for Type 3248 Angle Valve**i Note**

Height H7 is the minimum clearance for service work. The actuator dimensions and the height H3 in Table 6.1 must also be observed. The largest value applies.

Height H1 and the specified weights are reference values. The exact dimensions and weights depend on various factors, e.g. actuator size and overall height.

Table 5.1: Type 3248 Angle Valve with aluminum body, PN 16 to 40¹⁾ (Fig. 9)

Valve	DN	25	40	50	80	100	150
L	mm	98	133	133	159	184	236
H1	mm	825	827	827	1035	1120	1149
H4	mm	600	600	600	700	800	800
H5	mm	679	677	677	807	906	935
H7	mm	1050	900	900	900	1100	1100
Ød	mm	282	282	282	282	282	282
Welding ends/pipe connection		Ø35 x 3.5	Ø50 x 4	Ø60 x 4	Ø89 x 5	Ø114 x 6	Ø162 x 8
Weight without actuator	kg	19	31	31	51	95	115

¹⁾ Higher nominal pressures on request

Table 5.2: Type 3248 Angle Valve in stainless steel version, PN 16 to 40 (Fig. 10)

Valve	DN	25	40	50	80	100	150
L	mm	98	133	133	159	184	236
H1	mm	830	845	845	1017	1108	1101
H4	mm	600	600	600	650	750	750
H5	mm	684	695	695	788	893	887
H7	mm	1050	900	900	900	1100	1100
Ød	mm	282	282	282	282	282	282
Welding ends/pipe connection		Ø33.7 x 2.3	Ø48.3 x 2.6	Ø60.3 x 3.2	Ø88.9 x 4	Ø114.3 x 5	Ø168.3 x 5.6
Weight without actuator	kg	16.5	27	27	57	98	127

Table 5.3: Type 3248 Angle Valve in stainless steel version, PN 63 to 100 (Fig. 10)

Valve	DN	25	40	50	80	100	150
L	mm	98	133	133	159	184	236
H1	mm	798	798	798	795.5	943	1210
H4 ¹⁾	mm	400/600	400/600	400/600	400/600	500/600	550/600
H5 ¹⁾	mm	510/710	515/715	515/715	498/698	645/745	649/699
H7	mm	1050	900	900	900	1100	1100
Ød	mm	282	282	282	282	282	282
Welding ends/pipe connection		Ø33.7 x 3.2	Ø48.3 x 3.6	Ø60.3 x 4	Ø88.9 x 5.6	Ø114.3 x 6.3	Ø168.3 x 7.1
Weight without actuator	kg	18	31	31	61	107	186

¹⁾ Different overall height possible

Dimensional drawings

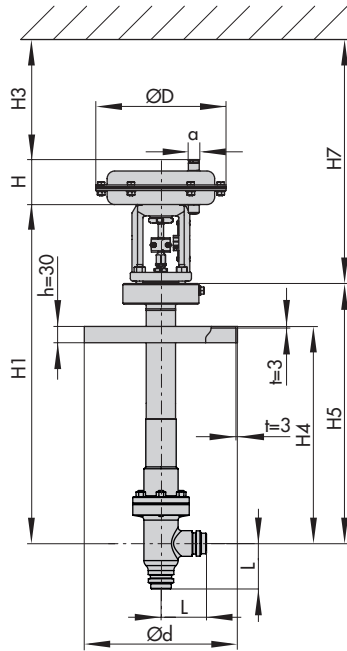

Fig. 9: Type 3248-1 Angle Valve with aluminum body

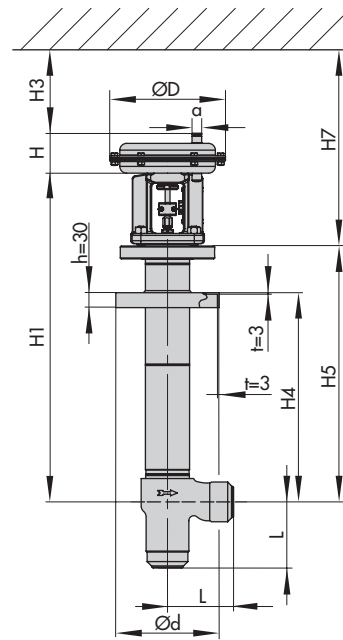

Fig. 10: Type 3248-1 Angle Valve with stainless steel body

Table 6: Dimensions and weights for Type 3271 and Type 3277 Pneumatic Actuators

Table 6.1: Dimensions in mm

Actuator area	cm ²	175	240	350	355	700	750	1000	1400-60	1400-120	2800
Diaphragm ØD	mm	215	240	280	280	390	394	462	530	534	770
H ¹⁾	mm	78	62	82	121	199	236	403	287	490 ³⁾ / 580 ⁴⁾	630 ³⁾ / 695 ⁴⁾
H3 ²⁾	mm	110	110	110	110	190	190	610	610	650	650
Height of yoke	Type 3277 mm	101	101	101	101	101	101	-	-	-	-
Thread	Type 3271	M30 x 1.5						M60 x 1.5		M100 x 2	
	Type 3277	M30 x 1.5						-	-	-	-
α	Type 3271	G ¼ (¼ NPT)	G ¼ (¼ NPT)	G ⅜ (⅜ NPT)	G ⅜ (⅜ NPT)	G ⅜ (⅜ NPT)	G ⅜ (⅜ NPT)	G ¾ (¾ NPT)	G ¾ (¾ NPT)	G 1 (1 NPT)	G 1 (1 NPT)
α2	Type 3277	G ⅜	G ⅜	G ⅜	G ⅜	G ⅜	G ⅜	-	-	-	-

¹⁾ Height with welded-on lifting eyelet or height of eyebolt according to DIN 580. Height of the swivel lifting hook may differ. Actuators up to 355 cm² without lifting eyelet

²⁾ Minimum clearance required to remove the actuator. Additionally observe H7 in Table 4 and Table 5. The largest value applies.

³⁾ Height for version with welded-on lifting eyelet (material EN-JS1030)

⁴⁾ Height for version with female thread (material 1.5638/A352 LC3)

Table 6.2: Weights in kg

Actuator area	cm ²	175	240	350	355	700	750	1000	1400-60	1400-120	2800
Weight	Type 3271 kg	6	5	8	15	22	36	80	70	175	450
	Type 3277 kg	10	9	12	19	26	40	-			

Table 7: Valve/actuator assignment**Table 7.1: PN 16 to 40**

Valve size	Stem diameter	Actuator area
DN 25 to 50	10 mm	175 to 750 cm ²
DN 80	16 mm	350 to 750 cm ²
DN 100 to 150	16 mm	350 to 1400-60 cm ²

Table 7.2: PN 63 to 100

Valve size	Stem diameter	Actuator area
DN 25	12 mm	175 to 750 cm ²
DN 40 to 80	16 mm	350 to 1400-60 cm ²
DN 100	16 mm	350 to 1400-120 cm ²
DN 150	40 mm	1000 to 2800 cm ²

The following specifications are required on ordering:

Type 3248 Valve	Globe or angle valve
Nominal size	DN ...
Nominal pressure	PN ...
Flow coefficient	K _{VS} ...
Characteristic	Equal percentage or linear
Body material	According to Table 2
Connection	Welding-neck ends or welding ends Pipe dimensions Height Cover plate
Pneumatic actuator	Type 3271 or Type 3277
Actuator area	... cm ²
Bench range	... bar
Fail-safe position	Fail-close or fail-open

Specifications subject to change without notice

