

Series 3730

Type 3730-0 Electropneumatic Positioner



Application

Single-acting or double-acting positioner for attachment to pneumatic control valves

Set point 4 to 20 mA
Travel 5.3 to 200 mm



The positioner ensures a predetermined assignment of the valve position (controlled variable x) to the input signal (set point w). It compares the input signal received from a control system to the travel of the control valve and issues a corresponding output signal pressure (output variable y).

Special features

- Simple attachment to common linear actuators with interface for SAMSON direct attachment, NAMUR rib, valves with rod-type yokes according to IEC 60534-6 (Fig. 1) and attachment according to VDI/VDE 3847
- Any desired mounting position of the positioner
- Calibrated travel sensor without gears susceptible to wear
- Analog pneumatic output prevents pulsing in case of leaking actuator
- Fast-reacting analog control loop
- High control accuracy (fine tuning) without dead band and continuous pneumatic output
- Two-wire system with small electrical load below 300 Ω for explosion-protected version and version without explosion protection
- Output pressure limitation enabled by DIP switch
- Selectable tight-closing function with fixed switching point
- Low air consumption of approx. 110 l_n/h independent of supply and output pressure
- Aluminum housing with IP 66 degree of protection
- Check valve in the exhaust air port
- Resistant to shock and vibrations
- Extended temperature range also for intrinsically safe operation
- Travel range selectable within the rated travel range by setting DIP switch
- Zero and span adjusted by potentiometers
- Set point range and direction of action adjustable by setting DIP switches, e.g. for split-range operation

Additional options

- Stainless steel housing



Principle of operation

The positioner is mounted on pneumatic control valves and is used to assign the valve position (controlled variable x) to the control signal (set point w). The positioner compares the electric control signal of a control system to the travel of the control valve and issues a signal pressure (output variable y) for the pneumatic actuator.

The positioner consists of a travel sensor system proportional to resistance, an analog i/p converter with a downstream air capacity booster and the electronics with microcontroller.

The position of the valve stem is transmitted as a linear travel motion over the pick-up lever to the travel sensor (2) and supplied to an analog PD controller (3). The PD controller compares this actual value to the DC control signal coming from the control system, e.g. a 4 to 20 mA signal. In case of a system deviation, the activation of the i/p converter (6) is changed so that the actuator of the control valve (1) is pressurized or vented accordingly over the downstream booster (7).

This causes the valve plug to move to the position determined by the set point.

The supply air is supplied to the booster and the pressure regulator (8). An intermediate flow regulator (9) with fixed settings is used to purge the positioner and, at the same time, guarantees trouble-free operation of the booster.

The output signal pressure supplied by the booster can be limited by enabling the DIP switch setting S5 (4).

The volume restriction (10) and the DIP switch S6 (4) are used to optimize the positioner by adapting it to the actuator size and changing the gain factor.

Operation

The user can adjust the potentiometers and DIP switches to change the positioner settings. The configuration of the positioner is facilitated by instructions included on the inside of the cover which are intended to ensure a quick and trouble-free adaptation of the positioner to the control valve.

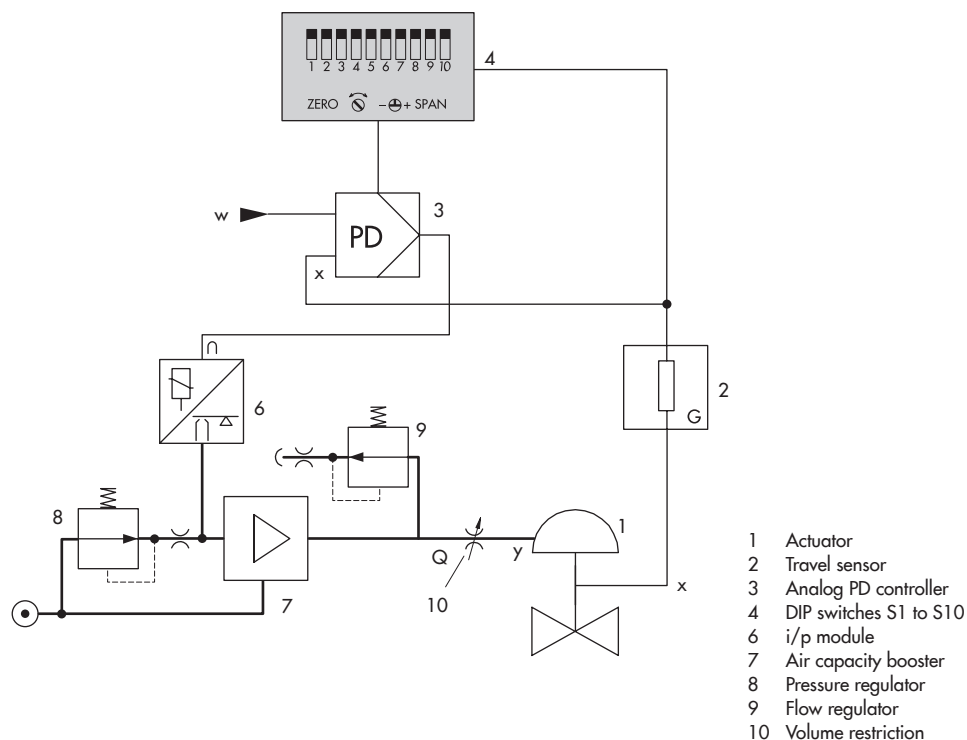



Fig. 2: Functional diagram of Type 3730-0 Positioner

Table 1: Technical data

Type 3730-0 Positioner (technical data in test certificates additionally apply to explosion-protected devices)			
Travel	Adjustable	Direct attachment to Type 3277 Actuator	5.3 to 30 mm
		Attachment to Type 3510 Micro-flow Valve	5.3 to 15 mm
		Attachment according to IEC 60534-6 (NAMUR)	5.3 to 200 mm
Travel range		Adjustable within the initialized travel/angle of rotation; travel can be restricted to 1/5 at the maximum	
Set point w	Signal range	4 to 20 mA, 4 to 12 mA and 12 to 20 mA Setting with DIP switches S6 and S7	
	Static destruction limit	100 mA	
Minimum current		3.6 mA	
Load impedance		≤ 6 V (corresponding to 300 Ω at 20 mA)	
Supply air	Supply air	1.4 to 7 bar (20 to 105 psi)	
	Air quality acc. to ISO 8573-1 (edition 2001-02)	Max. particle size and density: Class 4 · Oil content: Class 3 · Pressure dew point: Class 3 or at least 10 K below the lowest ambient temperature to be expected	
Signal pressure (output)		0 bar up to the capacity of the supply pressure Limitation to approx. 2.4 bar enabled by setting DIP switch S5	
Characteristic		Linear · Deviation ≤ 1 %	
Hysteresis		≤ 1 %	
Sensitivity		≤ 0.1 %	
Direction of action		Adjustable by changing DIP switch S4 setting	
Air consumption		Independent of supply air approx. 110 l _n /h at a supply pressure of 4 bar	
Air output capacity	Actuator filled with air	At Δp = 6 bar: 8.5 m _n ³ /h · At Δp = 1.4 bar: 3.0 m _n ³ /h · K _{Vmax(20 °C)} = 0.09	
	Actuator vented	At Δp = 6 bar: 14.0 m _n ³ /h · At Δp = 1.5 bar: 4.5 m _n ³ /h · K _{Vmax(20 °C)} = 0.15	
Permissible ambient temperature		-20 to 80 °C · -45 to 80 °C with metal cable gland The limits in the test certificate additionally apply for explosion-protected versions	
Influences	Temperature	≤ 0.15 %/10 K	
	Supply air	None	
	Effect of vibration	≤ 0.25 % up to 2000 Hz and 4 g according to IEC 770	
Electromagnetic compatibility		Complying with EN 61000-6-2, EN 61000-6-3, EN 61326-1 and NAMUR Recommendation NE 21	
Electrical connections		One M20 x 1.5 cable gland for 6 to 12 mm clamping range · Second M20 x 1.5 threaded connection additionally exists · Screw terminals for 0.2 to 2.5 mm ² wire cross-sections	
Explosion protection		See Table 2	
Degree of protection		IP 66/NEMA 4X	
Use in safety-instrumented systems (SIL)		Observing the requirements of IEC 61508, the systematic capability of the pilot valve for emergency venting as a component in safety-instrumented systems is given.	
		Use is possible on observing the requirements of IEC 61511 and the required hardware fault tolerance in safety-instrumented systems up to SIL 2 (single device/HFT = 0) and SIL 3 (redundant configuration/HFT = 1).	
Weight		1.0 kg	
Materials	Housing	Die-cast aluminum EN AC-ALSi12(Fe) (EN AC-44300) acc. to DIN EN 1706, chromated and powder coated · Special version: stainless steel 1.4581	
	External parts	Stainless steel 1.4571 and 1.4301	
	Cable gland	M20x1.5, black polyamide	
Compliance			

Dimensions in mm

Direct attachment

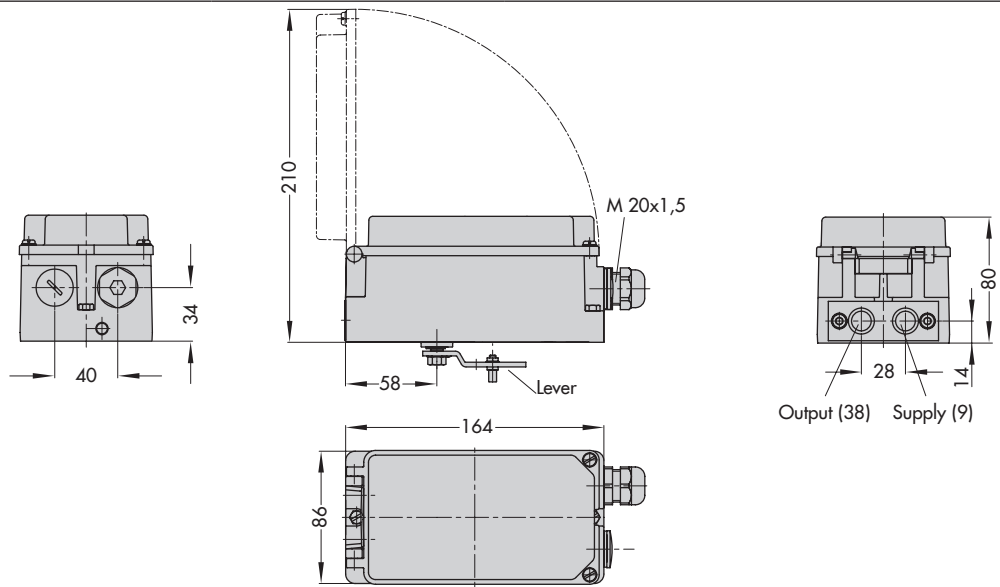

Attachment according to IEC 60534-6 (NAMUR)

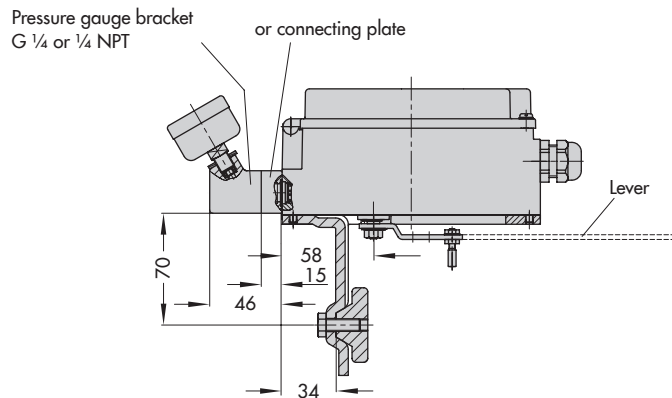

Attachment according to VDI/VDE 3847

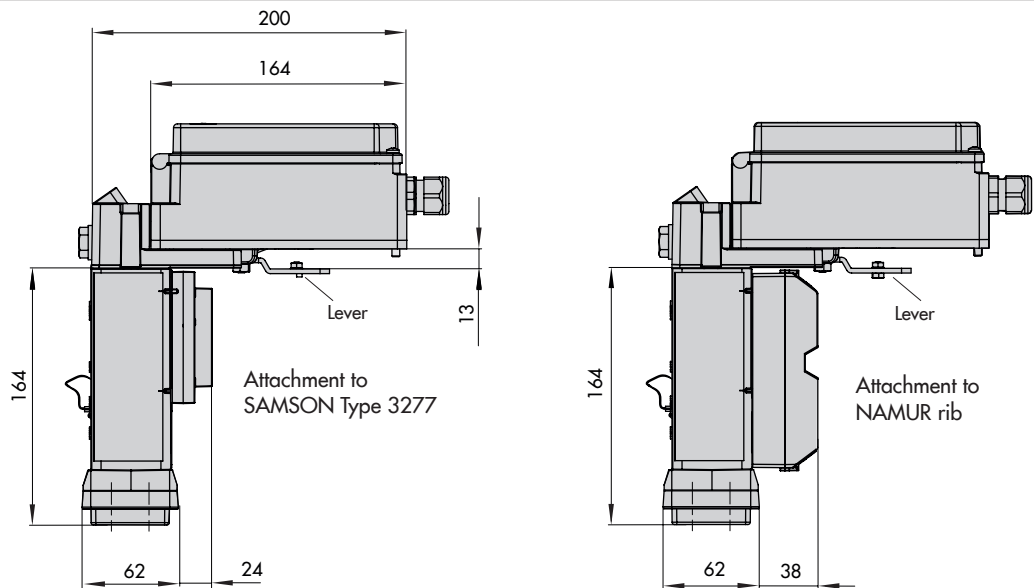

Lever

Lever	x	y	z
S	17 mm	25 mm	33 mm
M	25 mm	50 mm	66 mm
L	70 mm	100 mm	116 mm
XL	100 mm	200 mm	216 mm

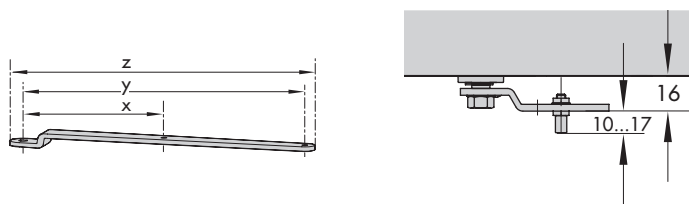







Table 2: Explosion protection certificates

Type	Certification			Type of protection/comments
3730	STCC	Number	972	0Ex ia IIC T6X 2Ex s II T6 X
		Valid until	2017-10-01	
	 EC type examination certificate	Number	PTB 03.ATEX 2099	II 2G Ex ia IIC T6 Gb II 2D Ex ia IIIC T80°C Db
		Date	2013-09-17	
		Number	RU C-DE.08.B.00113	1Ex ia IIC T6/T5/T4 Gb X Ex tb IIIC T80°C Db X
		Date	2013-11-15	
		Valid until	2018-11-14	
	CSA	Number	1613095	Ex ia IIC T6; Class I, Zone 0; Class II, Groups E, F, G Ex nA II T6; Class I, Zone 2; Class II, Div. 2, Groups E, F, G
		Date	2005-02-11	
	FM	Number	3021579	Class I, Zone 0 AEx ia IIC; Class I, II, III, Div.1, Groups A, B, C, D, E, F, G Class I, Div.2, Groups A, B, C, D; Class II, Div.2, Groups F, G
Date		2004-12-01		
 EC type examination certificate	Number	PTB 03.ATEX 2099	II 2D Ex tb IIIC T80°C Db IP66	
	Date	2013-09-17		
JIS	Number	TC17330	Ex ia IIC T6	
	Date	2014-07-29		
	Valid until	2017-07-28		
 EC type examination certificate	Number	PTB 03.ATEX 2179 X	II 3G Ex nA II T6; II 3G Ex ic IIC T6; II 3D Ex tc IIIC T80°C IP66	
	Date	2013-09-17		
	Number	RU C-DE.08.B.00113	2Ex nA IIC T6/T5/T4 Gc X 2Ex ic IIC T6/T5/T4 Gc X 2Ex tc IIIC T80°C Dc X	
	Date	2013-11-15		
	Valid until	2018-11-14		

Article code

Positioner	Type 3730-0	x	0	0	0	0	0	0	0	0	0	x	0	0	x	0	x	x	
Explosion protection																			
Without		0																	
ATEX: II 2G Ex ia IIC T6 Gb; II 2D Ex ia IIIC T80°C Db		1																	
FM/CSA: Class I, Zone 0 AEx ia IIC; Class I, II, III, Div.1, Groups A-G; Class I, Div.2, Groups A-D; Class II, Div.2, Groups F, G/ Ex ia IIC T6; Class I, Zone 0; Class II, Groups E-G; Ex nA II T6; Class I, Zone 2; Class II, Div. 2, Groups E-G		3																	
ATEX: II 2G Ex tb IIIC T80°C Db IP66		5																	
JIS: Ex ia IIC T6		7																	
ATEX: II 3G Ex nA II T6; II 3G Ex ic IIC T6; II 3D Ex tc IIIC T80°C IP66		8																	
Housing material																			
Aluminum												0							
Stainless steel 1.4581												1							
Special applications																			
Without														0					
Compatible with paint														1					
Exhaust air with 1/4 NPT connection, back of housing sealed														2					
Special version																			
Without																	0	0	
EAC Ex: 1Ex ia IIC T6/T5/T4 Gb X; Ex tb IIIC T80°C Db X		1															1	4	
EAC Ex: 2Ex nA IIC T6 /T5/T4 Gc X; 2Ex ic IIC T6/T5/T4 Gc X; 2Ex tc IIIC T80°C Dc X		8															2	0	
Attachment according to VDI/VDE 3747 with interface														6					
Attachment according to VDI/VDE 3747 prepared for interface														7					

Mounting the positioner

The Type 3730 Electropneumatic Positioner can be attached directly to the Type 3277 Actuator over a connection block.

In actuators with fail-safe action "actuator stem extends" and Type 3277-5 Actuator (120 cm²), the signal pressure is routed over an internal hole in the actuator yoke to the actuator.

In actuators with fail-safe action "actuator stem retracts" and in actuators with effective diaphragm areas of 175 cm² or larger, the signal pressure is routed to the actuator over ready-made external piping.

Using the appropriate bracket, the positioner can also be attached according to IEC 60534-6-1 (NAMUR recommendation). The positioner can be mounted on either side of the control valve.

A special version of the positioner allows it to be attached according to VDI/VDE 3847. This type of attachment allows the positioner to be replaced quickly while the process is running by blocking the air in the actuator. The positioner can be attached directly to the Type 3277 Actuator using an adapter bracket or adapter block. Alternatively, it can be attached to the NAMUR rib of a control valve using an additional NAMUR connection block.

Ordering text

Type 3730-0x Positioner

- Without pneumatic connecting rail
(only when directly attached to Type 3277)
- With pneumatic connecting rail ISO 228/1-G ¼
- With pneumatic connecting rail ¼-18 NPT
- Without/with pressure gauge up to max. 6 bar
- Attachment to Type 3277 Actuator (120 to 750 cm²)
- Attachment acc. to IEC 60534-6-1 (NAMUR)
Travel: ... mm, if applicable, stem diameter: ... mm
- Attachment according to VDI/VDE 3847
Valve travel: ... mm, if applicable, rod diameter: ... mm
- Adapter M20x1.5 to ½ NPT
- Metal cable gland

Specifications subject to change without notice



SAMSON AG · MESS- UND REGELTECHNIK
Weismüllerstraße 3 · 60314 Frankfurt am Main, Germany
Phone: +49 69 4009-0 · Fax: +49 69 4009-1507
samson@samson.de · www.samson.de

T 8384-0 EN

2017-06-14 · English