

Series 3730

Type 3730-2 Electropneumatic Positioner



Application

Single-acting or double-acting positioner for attachment to pneumatic control valves. Self-calibrating, automatic adaptation to valve and actuator.

Set point	4 to 20 mA
Valve travel	3.6 to 300 mm
Opening angle	24 to 100°



The positioner ensures a predetermined assignment of the valve position (controlled variable x) to the input signal (set point w). It compares the input signal received from a control system to the travel or rotational angle of the control valve and issues a corresponding output signal pressure (output variable y).

Special features

- Simple attachment to all common linear and rotary actuators
 - SAMSON direct attachment (Fig. 1)
 - NAMUR rib (Fig. 2)
 - Attachment to rod-type yokes acc. to IEC 60534-6-1
 - Attachment according to VDI/VDE 3847
 - Rotary actuator attachment according to VDI/VDE 3845 (Fig. 3)
- Any desired mounting position of the positioner (but not suspended)
- Simple single-knob, menu-driven operation
- LCD easy to read in any mounted position due to selectable reading direction
- Configurable with a PC over the SSP interface using the TROVIS-VIEW software
- Variable, automatic start-up with four different initialization modes
- Preset parameters - only values deviating from the standard need to be adjusted
- Calibrated travel sensor without gears susceptible to wear
- Sub initialization mode (substitution) allows the positioner to be started up in case of emergency whilst the plant is running without the valve moving through the whole travel range.
- Permanent storage of all parameters in EEPROM (protected against power failure)
- Two-wire system with small electrical load between 300 and 350 Ω depending on version (see Table 1)
- Adjustable output pressure limitation
- Activatable tight-closing function
- Continuous monitoring of zero point
- Integrated temperature sensor and operating hours counter

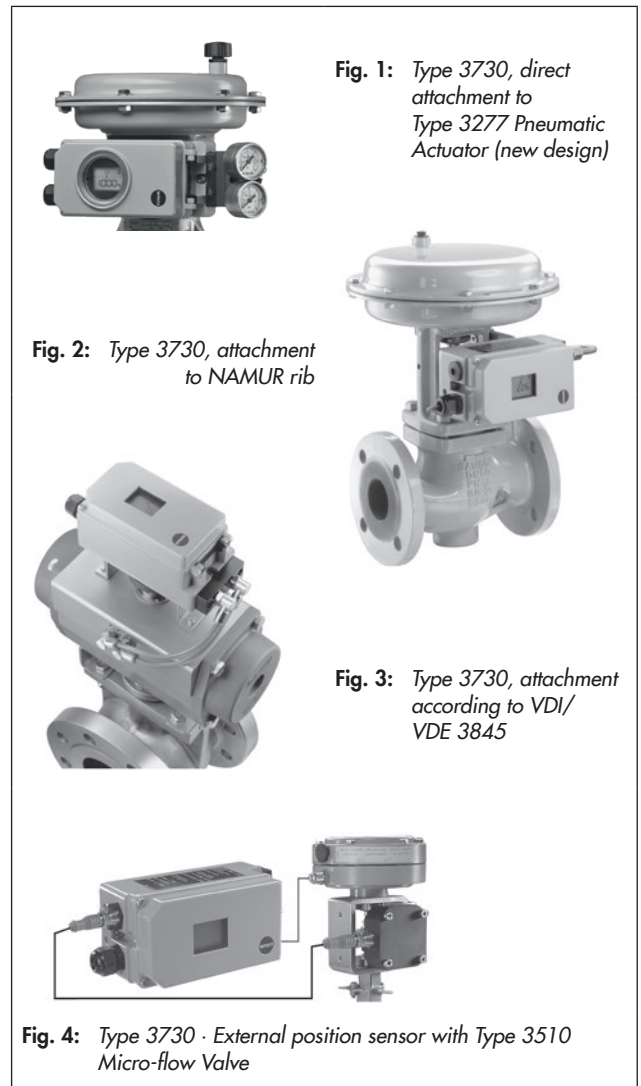

Fig. 1: Type 3730, direct attachment to Type 3277 Pneumatic Actuator (new design)

Fig. 2: Type 3730, attachment to NAMUR rib

Fig. 3: Type 3730, attachment according to VDI/VDE 3845

Fig. 4: Type 3730 · External position sensor with Type 3510 Micro-flow Valve

- Two standard programmable position alarms
- Self-diagnostics; alarms as condensed state conforming to NAMUR Recommendation NE 107, issued over a fault alarm contact or optional analog position transmitter
- Integrated EXPERTplus diagnostics for control valves (► T 8389-1)

Version

- **Type 3730-2** · Electropneumatic positioner for control valves, on-site operation, local communication with SSP interface, EXPERTplus diagnostics

Additional options

- Inductive limit contact with proximity switches
- Analog position transmitter with two-wire transmitter
- Forced venting function with solenoid valve
- Binary input
- External position sensor (Fig. 4)
- Stainless steel housing
- Leakage sensor to monitor the seat leakage

Principle of operation

The positioner is mounted on pneumatic control valves and is used to assign the valve position (controlled variable x) to the control signal (set point w). The positioner compares the electric control signal of a control system to the travel or rotational angle of the control valve and issues a signal pressure (output variable y) for the pneumatic actuator.

The positioner mainly consists of an electric travel sensor system (2), an analog i/p module with a downstream air capacity booster and the electronics with the microcontroller (5).

When a set point deviation occurs, the actuator is either vented or filled with air. If necessary, the signal pressure change can be slowed down with a volume restriction that can be connected as necessary. The signal pressure to the actuator can be limited by software to 1.4, 2.4 or 3.7 bar.

A constant air stream with a fixed set point to the atmosphere is created by flow regulator (9) with a fixed set point. The i/p module (6) is supplied with a constant upstream pressure by the pressure regulator (8) to compensate for any fluctuations in the supply pressure.

Operation

The positioner is operated with a user-friendly rotary pushbutton. The parameters are selected by turning the knob, pushing it activates the required setting. In the menu, all parameters are listed in one level, eliminating the need to search in submenus. All parameters can be checked and changed on site.

All values are displayed on the LCD. The reading direction of the LCD can be rotated by 180°.

The closing direction of the control valve is indicated to the positioner by setting the slide switch "Air to open/Air to close". It assigns the CLOSED position of the control valve to the 0 % reading.

The INIT key activates initialization which is started according to the ready adjusted parameters (autotune). After initialization is completed, the positioner immediately starts closed-loop operation.

To configure the positioner with SAMSON's TROVIS-VIEW software, the positioner is equipped with an additional digital interface to be connected to the RS-232 or USB interface of a PC.

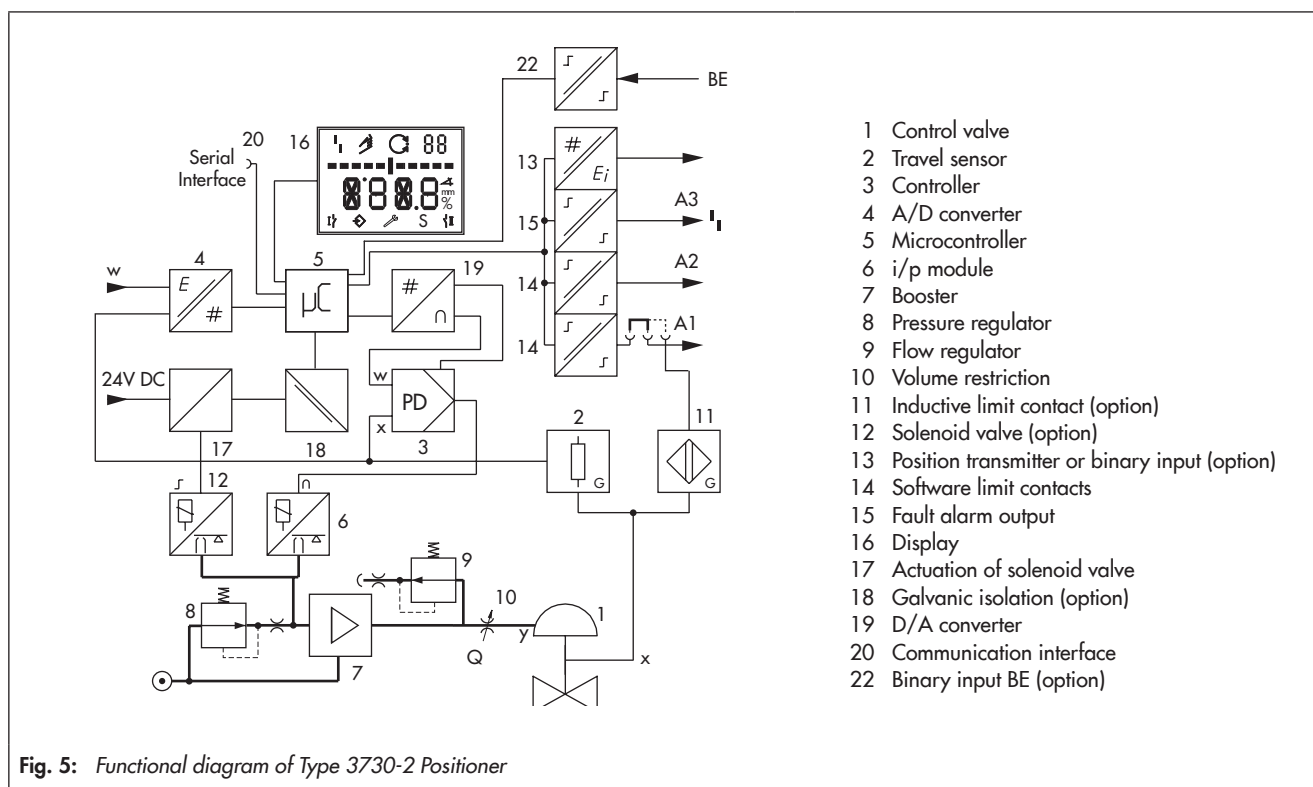



Table 1: Technical data for Type 3730-2 Positioner

Type 3730-2 Positioner		The technical data for the explosion-protected devices may be restricted by the limits specified in the test certificates.	
Valve travel	Adjustable	Direct attachment to Type 3277 Actuator	3.6 to 30 mm
		Attachment according to IEC 60534-6 (NAMUR)	3.6 to 300 mm
		Attachment according to VDI/VDE 3847	3.6 to 300 mm
		Attachment to rotary actuators (VDI/VDE 3845)	24 to 100° opening angle
Travel range	Adjustable	Adjustable within the initialized travel/angle of rotation of the valve; travel can be restricted to 1/5 at the maximum.	
Set point w	Signal range	4 to 20 mA · Two-wire device, reverse polarity protection Minimum span 4 mA	
	Static destruction limit	100 mA	
Minimum current		3.6 mA for display · 3.8 mA for operation	
Load impedance		Without explosion protection: ≤6 V (corresponds to 300 Ω at 20 mA) · Explosion-protected versions: ≤7 V (corresponds to 350 Ω at 20 mA)	
Supply air	Supply pressure	1.4 to 7 bar (20 to 105 psi)	
	Air quality acc. to ISO 8573-1	Max. particle size and density: Class 4 · Oil content: Class 3 · Pressure dew point: Class 3 or at least 10 K below the lowest ambient temperature to be expected	
Signal pressure (output)		0 bar up to the capacity of the supply pressure · Can be limited to 1.4 bar/2.4 bar/3.7 bar ± 0.2 bar by software	
Characteristic	Adjustable	Linear/Equal percentage/Reverse equal percentage User-defined (over operating software and communication) Butterfly valve, rotary plug valve and segmented ball valve: Linear/equal percentage	
	Deviation	≤1 %	
Hysteresis		≤0.3 %	
Sensitivity		≤0.1 %	
Transit time		Venting or filling with air adjustable separately up to 240 s by software	
Direction of action		Reversible	
Air consumption, steady state		Independent of supply air approx. 110 l _n /h	
Air output capacity	to fill actuator with air	At Δp = 6 bar: 8.5 m _n ³ /h · At Δp = 1.4 bar: 3.0 m _n ³ /h · K _{Vmax(20 °C)} = 0.09	
	to vent actuator	At Δp = 6 bar: 14.0 m _n ³ /h · At Δp = 1.4 bar: 4.5 m _n ³ /h · K _{Vmax(20 °C)} = 0.15	
Permissible ambient temperature		-20 to +80 °C (all versions) -45 to +80 °C with metal cable gland The temperature limits for the explosion-protected devices may be restricted by the limits specified in the test certificates.	
Influences	Temperature	≤0.15 %/10 K	
	Supply air	None	
	Effect of vibration	≤0.25 % up to 2000 Hz and 4 g according to IEC 770	
Electromagnetic compatibility		Complying with EN 61000-6-2, EN 61000-6-3, EN 61326-1 and NAMUR Recommendation NE 21	
Electrical connections		One M20x1.5 cable gland for 6 to 12 mm clamping range Second M20x1.5 threaded connection additionally available Screw terminals for 0.2 to 2.5 mm ² wire cross-section	
Degree of protection		IP 66/NEMA 4X	
Use in safety-instrumented systems (SIL)		Observing the requirements of IEC 61508, the systematic capability of the pilot valve for emergency venting as a component in safety-instrumented systems is given.	
Emergency venting at 0 mA set point and using optional solenoid valve		Use is possible on observing the requirements of IEC 61511 and the required hardware fault tolerance in safety-instrumented systems up to SIL 2 (single device/HFT = 0) and SIL 3 (redundant configuration/HFT = 1).	
Explosion protection		See Table 3	
Compliance			
Communication (local)		SAMSON SSP interface and serial interface adapter	
Software requirements (SSP)		TROVIS-VIEW with database module 3730-2	





Binary contacts			
For connection to	Binary input of a PLC acc. to IEC 61131-2 $P_{max} = 400 \text{ mW}$ or for connection to NAMUR switching amplifier acc. to EN 60947-5-6	NAMUR switching amplifier acc. to EN 60947-5-6	
Two software limit contacts, reverse polarity protection, floating, configurable switching characteristics (default settings in table below)			
Signal state	Version	No explosion protection	Ex
	No response	Effectively non-conducting	$\leq 1.0 \text{ mA}$
	Response	Conductive ($R = 348 \Omega$)	$\geq 2.2 \text{ mA}$
One fault alarm contact			
Signal state	Version	No explosion protection	Ex
	No fault alarm	Conductive ($R = 348 \Omega$)	$\geq 2.2 \text{ mA}$
	Fault alarm	Effectively non-conducting	$\leq 1.0 \text{ mA}$
Materials			
Housing	Die-cast aluminum EN AC-ALSi12(Fe) (EN AC-44300) acc. to DIN EN 1706 · Chromated and powder paint coated · Special version: stainless steel 1.4581		
External parts	Stainless steel 1.4571 and 1.4301		
Cable gland	M20 x 1.5, black polyamide		
Weight	Approx. 1.0 kg · Special stainless steel version: 2.2 kg		

Table 2: Options for Type 3730-2 Positioner

Solenoid valve · Approval acc. to IEC 61508/SIL	
Input	24 V DC · Galvanically isolated and reverse polarity protection · Static destruction limit 40 V Current consumption $I = \frac{U - 5.7 \text{ V}}{3840 \Omega}$ (corresponding to 4.8 mA at 24 V/114 mW)
Signal '0' (no response)	$< 12 \text{ V}$ (emergency venting at 0 V)
Signal '1' (response)	$> 19 \text{ V}$
Service life	$> 5 \times 10^6$ switching cycles
K_v coefficient	0.15
Analog position transmitter	
Supply air	12 to 30 V DC · Reverse polarity protection · Static destruction limit 40 V
Output signal	4 to 20 mA
Operating direction	Reversible
Operating range	-10 to +114 %
Characteristic	Linear
Hysteresis	Same as positioner
High-frequency influence	Same as positioner
Other influences	Same as positioner
Fault alarm	Issued as status current $2.4 \pm 0.1 \text{ mA}$ or $21.6 \pm 0.1 \text{ mA}$
Pepperl+Fuchs inductive limit contact	
	For connection to switching amplifier according to EN 60947-5-6. Can be used in combination with a software limit contact.
SJ2-SN proximity switch	Measuring plate not detected: $\geq 3 \text{ mA}$ · Measuring plate detected: $\leq 1 \text{ mA}$

External position sensor		
Valve travel	Same as positioner	
Cable	10 m · Flexible and durable · With M12x1 connector · Flame-retardant acc. to VDE 0472 Resistant to oils, lubricants and coolants as well as other aggressive media	
Permissible ambient temperature	-40 to +90 °C with a fixed connection between positioner and position sensor · The limits in the test certificate additionally apply for explosion-protected versions	
Immunity to vibration	Up to 10 g in the range of 10 to 2000 Hz	
Degree of protection	IP 67	
Leakage sensor · Suitable for operation in hazardous areas		
Temperature range	-40 to +130 °C	
Tightening torque	20 ±5 Nm	
Binary input · Galvanically isolated · Switching behavior configured over software (e.g. TROVIS-VIEW, DTM)		
Active switching behavior (default setting)		
Connection	For external switch (floating contact) or relay contact	
Electric data	Open-circuit voltage when contact is open: max. 10 V Pulsed DC current reaching peak value of 100 mA and RMS value of 0.01 mA when contact is closed	
Contact	Closed, $R < 20 \Omega$	ON switching state (default setting)
	Open, $R > 400 \Omega$	OFF switching state (default setting)
Passive switching behavior		
Connection	For externally applied DC voltage, reverse polarity protection	
Electric data	3 to 30 V · Static destruction limit 40 V · Current consumption 3.7 mA at 24 V	
Voltage	>6 V: ON switching state (default setting) · <1 V: OFF switching state (default setting)	

Table 3: Explosion protection certificates

Type	Certification			Type of protection/comments
-21	STCC	Number	972	0Ex ia IIC T6X 2Ex s II T6X
		Valid until	2017-10-01	
	 EU type examination certificate	Number	PTB 00 ATEX 2158	II 2G Ex ia IIC T6 Gb, II 2D Ex ia IIIC T80°C Db
		Date	2016-08-17	
		Number	RU-C-DE 08 B.00697	1Ex ia IIC T6/T5/T4 Gb X; Ex tb III T 80°C Db X
		Date	2014-12-15	
		Valid until	2019-12-14	
-23	IECEX	Number	IECEX PTB 05.0007	Ex ia IIC T6...T4 Gb; Ex ia IIIC T80°C Db
		Date	2016-11-29	
	CCoE	On request		
	KCS	Number	11-KB4BO-0214	Ex ia IIC T6/T5/T4
		Date	2011-10-24	
		Valid until	2017-10-24	
-25	NEPSI	Number	GYJ14.1286	Ex ia IIC T4...T6 Gb
		Date	2014-11-05	
		Valid until	2019-11-04	
-27	CSA	Number	1330129	Ex ia IIC T6, Class I Zone 0; Class I, Groups A, B, C, D; Class II, Groups E, F, G; Class III; Type 4 Enclosure
		Date	2009-02-19	Class I, Zone 2; Class I, Div. 2, Groups A, B, C, D; Class II, Div. 2, Groups E, F, G; Class III; Type 4 Enclosure
-28	FM	Number	ID 3012394	Class I, Zone 0 AEx ia IIC; Class I,II,III, Div.1, Groups A, B, C, D, E, F, G; Class I, Div.2, Groups A, B, C, D; Class II,III, Div.2, Groups F, G; Type 4X
		Date	2011-08-11	
-29	 EC type examination certificate	Number	PTB 00 ATEX 2158	II 2D Ex tb IIIC T80°C Db
		Date	2016-08-17	
-30	IECEX	Number	IECEX PTB 05.0007	Ex tb IIIC T80°C Db
		Date	2016-11-29	
-31	JIS	Number	TC18159	Ex ia IIC T6
		Valid until	2019-11-26	
	 Statement of conformity	Number	PTB 03 ATEX 2016 X	II 3G Ex nA IIC T6 Dc, II 3D Ex tc IIIC T80°C Dc
		Date	2016-08-31	
-32		Number	RU-C-DE 08 B.00697	2Ex nA IIC T6/T5/T4 Gc X 2Ex ic IIC T6/T5/T4 Gc X Ex tc IIIC T 80°C Dc X
		Date	2014-12-15	
		Valid until	2019-12-14	
	IECEX	Number	IECEX PTB 05.0007	Ex nA IIC T6...T4 Gc; Ex tc IIIC T80°C Dc
	Date	2016-11-29		
-33	NEPSI	Number	GYJ14.1287X	Ex ic IIC T4...T6 Gc Ex nA IIC T4...T6 Gc
		Date	2014-11-05	
		Valid until	2019-11-04	

The test certificates are included in the mounting and operating instructions or are available on request.
Refer to Data Sheet ▶ T 8379 for Ex d approvals of Type 3770 Field Barrier

Mounting the positioner

The Type 3730 Electropneumatic Positioner can be attached directly to the Type 3277 Actuator (175 to 750 cm²) over a connection block. In actuators with "actuator stem extends" fail-safe action, the signal pressure is routed over an internal hole in the actuator yoke to the actuator. In actuators with "actuator stem retracts" fail-safe action, the signal pressure is routed to the actuator over ready-made external piping.

Using the appropriate bracket, the positioner can also be attached according to IEC 60534-6-1 (NAMUR recommendation). The positioner can be mounted on either side of the control valve.

A pair of universal brackets is used for the attachment to Type 3278 Rotary Actuators or other rotary actuators according to VDI/VDE 3845. The rotary motion of the actuator is transferred to the positioner over a coupling wheel with travel indication.

A special version of the positioner allows it to be attached according to VDI/VDE 3847. This type of attachment allows the positioner to be replaced quickly while the process is running by blocking the air in the actuator. The positioner can be attached directly to the Type 3277 Actuator using an adapter bracket or adapter block. Alternatively, it can be attached to the NAMUR rib of a control valve using an additional NAMUR connection block.

A reversing amplifier is necessary for double-acting, springless actuators for the second opposing signal pressure.

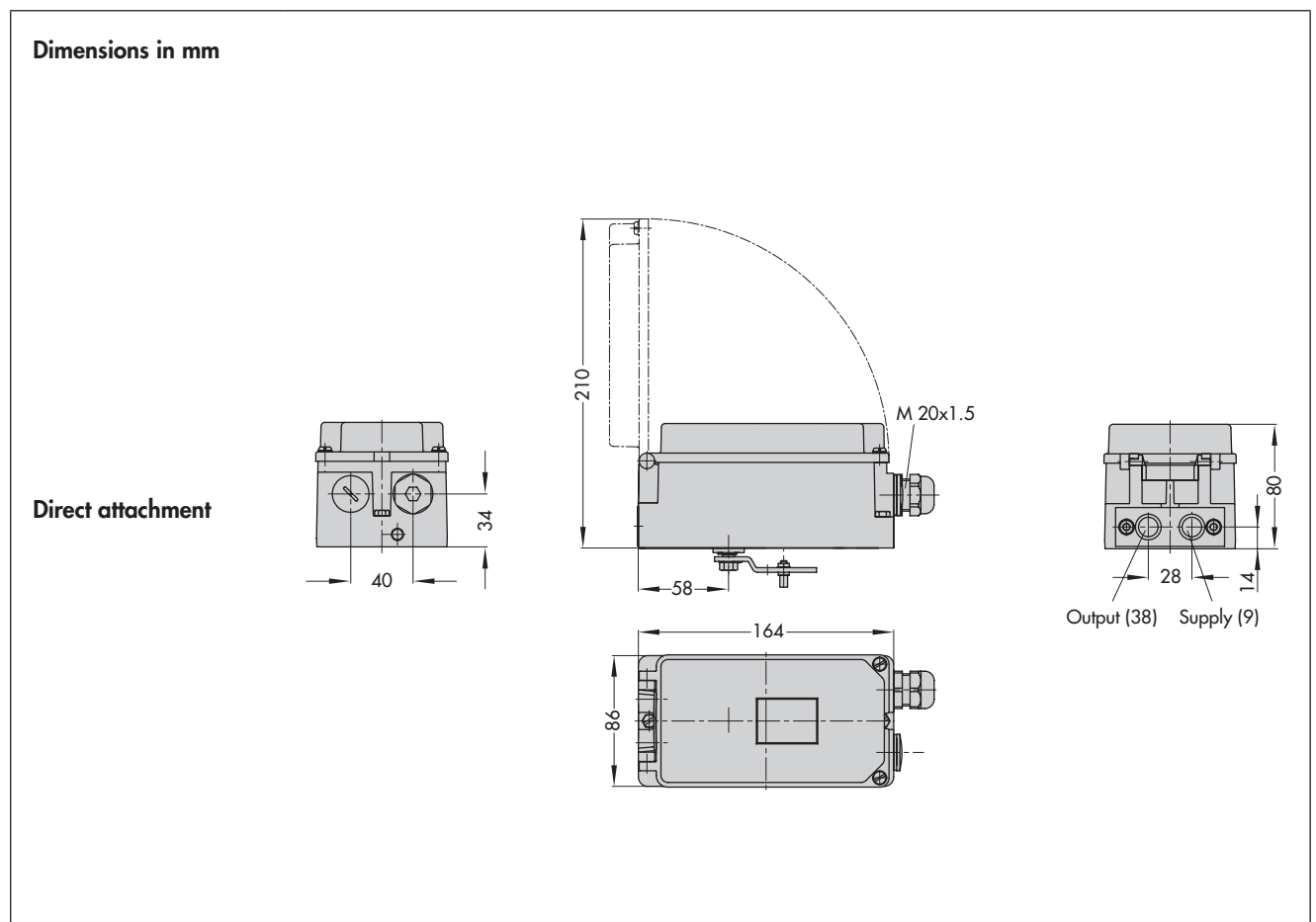

NAMUR attachment

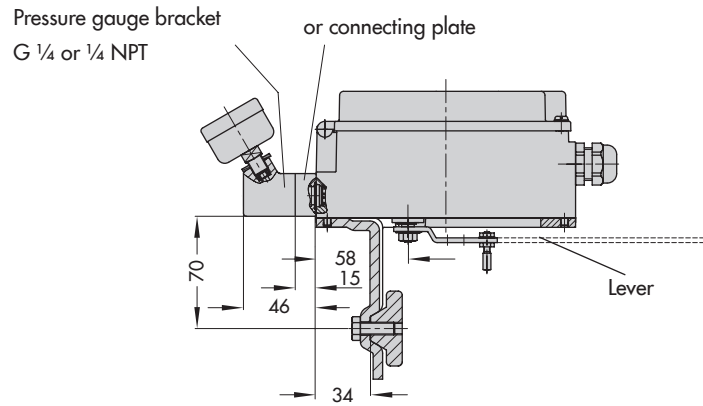

Attachment according to VDI/VDE 3847

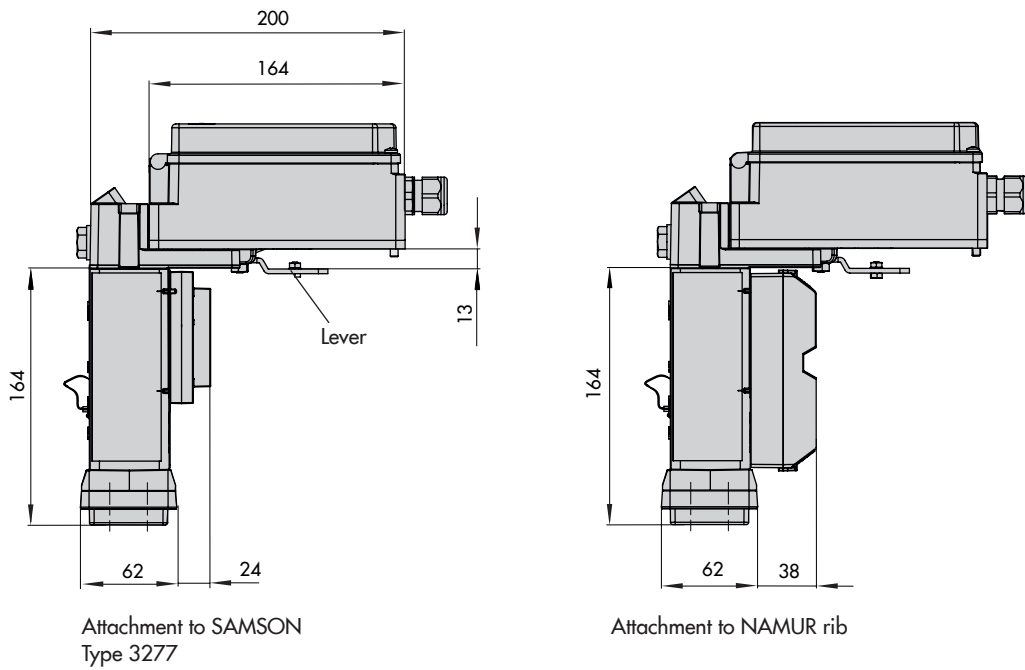

External position sensor

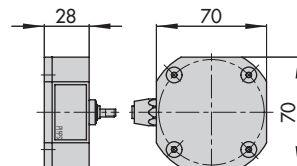

Attachment to rotary actuators

VDI/VDE 3845 (Sept. 2010)

Fixing level 1

Size AA1 to AA4

Light version

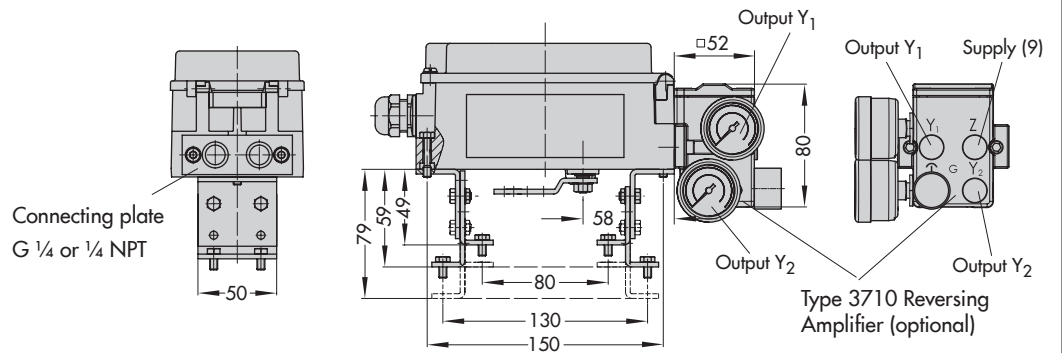

Mounting unit
CrNiMo steel bracket

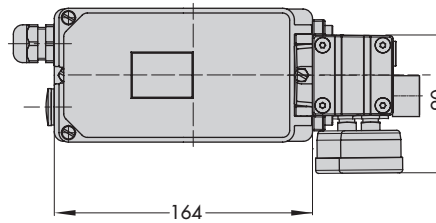

Heavy-duty version

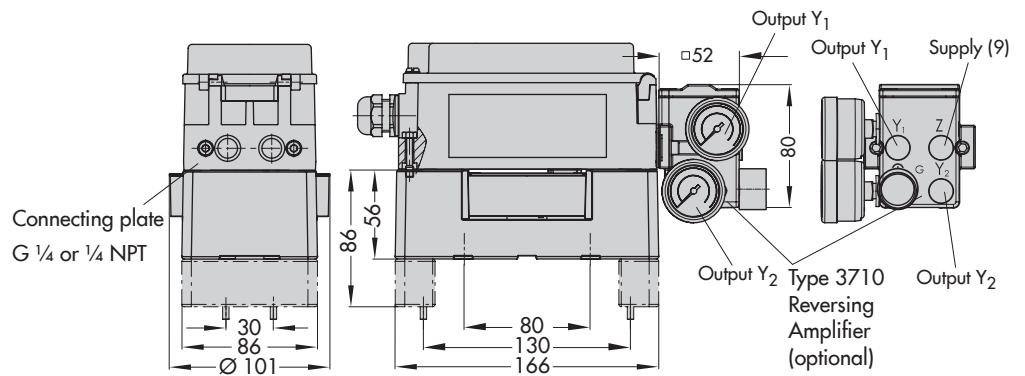

Lever

Lever	x	y	z
S	17 mm	25 mm	33 mm
M	25 mm	50 mm	66 mm
L	70 mm	100 mm	116 mm
XL	100 mm	200 mm	216 mm

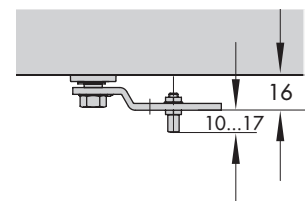
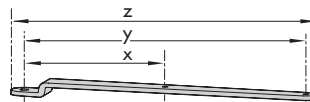

Ordering text

Type 3730-2... Positioner

- Without pneumatic connecting rail
(only when directly attached to Type 3277)
- With pneumatic connecting rail ISO 228/1-G ¼
- With pneumatic connecting rail ¼-18 NPT
- Without/with pressure gauge up to max. 6 bar
- Attachment to Type 3277 Actuator (175 to 750 cm²)
- Attachment according to IEC 60534-6-1 (NAMUR)
Valve travel: ... mm, if applicable, rod diameter: ... mm
- Attachment according to VDI/VDE 3847
Valve travel: ... mm, if applicable, rod diameter: ... mm
- Attachment to Type 3278 Rotary Actuator (160/320 cm²),
mounting unit with CrNiMo steel bracket or heavy-duty
attachment
- Attachment to rotary actuators acc. to VDI/VDE 3845,
mounting unit with CrNiMo steel bracket or heavy-duty
attachment
- Pneumatic reversing amplifier for double-acting actuators
with connection acc. to ISO 228/1-G ¼ or ¼-18 NPT
- Adapter M20x1.5 to ½ NPT
- Metal cable gland
- Special version: housing made of CrNiMo steel

Article code

Positioner	Type 3730-2 x x x x x x x x 0 x 0 0 x 0 x x										
With LCD and autotune, 4 to 20 mA set point, two software limit contacts, one fault alarm contact											
Explosion protection											
Without	0										
ATEX II 2G Ex ia IIC T6 Gb, II 2D Ex ia IIIC T80°C Db	1										
CSA Ex ia IIC T6, Class I Zone 0; Class I, Groups A, B, C, D; Class II, Groups E, F, G; Type 4 Enclosure; Class I, Zone 2; Class I, II, Div. 2, Groups A, B, C, D; Class II, Div. 2, Groups E, F, G; Class III; Type 4 Enclosure	3										
FM Class I, Zone 0 AEx ia IIC; Class I,II,III, Div.1, Groups A, B, C, D, E, F, G; Class I, Div.2, Groups A, B, C, D; Class II,III, Div.2, Groups F, G											
ATEX II 2D Ex tb IIIC T80°C Db	5										
JIS Ex ia IIC T6	7										
ATEX II 3G Ex nA IIC T6 Dc, II 3D Ex tc IIIC T80°C Dc	8										
Option (additional equipment)											
Inductive limit contact											
Without	0										
SJ2-SN (NC contact)	1										
Solenoid valve											
Without	0										
With, 24 V DC	4										
Analog position transmitter											
Without			0								
With			1	0	0	0					
External position sensor											
Without				0							
With	0			1				0			
Prepared connection	0			2							
Leakage sensor											
Without						0					
With			0	0	1	0					
Binary input											
Without								0			
With			0	0	0	2					
Diagnostics											
EXPERTplus								4			
Housing material											
Aluminum (standard)								0			
Stainless steel 1.4581			0					1			
Special application											
Without										0	
Device completely free of paint-impairing substances										1	
Exhaust air with ¼ NPT connection, back of housing sealed										2	
Attachment according to VDI/VDE 3847 including interface										6	
Attachment according to VDI/VDE 3847 prepared for interface										7	
Special version											
Without										0	0
IECEX Ex ia IIC T6...T4 Gb; Ex ia IIIC T80°C Db	1									1	2
Ex tb IIIC T80°C Db	5									3	4
Ex nA IIC T6...T4 Gc; Ex tc IIIC T80°C Dc	8									1	3
EAC 1Ex ia IIC T6/T5/T4 Gb X; Ex tb III T 80°C Db X	1									1	4
Ex 2Ex nA IIC T6/T5/T4 Gc X; 2Ex ic IIC T6/T5/T4 Gc X; Ex tc IIIC T 80°C Dc X	8									2	0

Specifications subject to change without notice



SAMSON AG · MESS- UND REGELTECHNIK
Weismüllerstraße 3 · 60314 Frankfurt am Main, Germany
Phone: +49 69 4009-0 · Fax: +49 69 4009-1507
samson@samson.de · www.samson.de

T 8384-2 EN

2017-04-26 · English