

Electropneumatic Ex d Positioner Type 3731-3 with HART® communication

Application

Single-acting or double-acting Ex d positioner for attachment to pneumatic control valves. Self-calibrating, automatic adaptation to valve and actuator.

Reference variable	4 to 20 mA
Travels	3.6 to 200 mm
Opening angle	24 to 100°



The electropneumatic positioner is used to ensure a preselected assignment between the valve stem position (controlled variable x) and the control signal (reference variable w). In this process, the output signal from a control device is compared to the travel/opening angle of a control valve and an output signal pressure (output variable y) is issued.

Special features

- Easy attachment to common linear and rotary actuators over SAMSON direct attachment interface, NAMUR rib, or to control valves with rod-type yokes acc. to IEC 60534-6-1 or to rotary actuators according to VDI/VDE 3845
- Any desired mounting position of the positioner
- Simple one-knob, menu-driven operation also in hazardous areas
- LCD easy to read in any mounting position due to selectable reading direction
- Configurable with a PC over the SSP serial interface using the TROVIS-VIEW software
- Variable, automatic commissioning using four initialization modes
- Preset parameters, only values deviating from the standard settings must be adjusted
- Calibrated travel sensor without gears susceptible to wear
- The "Sub" initialization mode (substitution) allows the positioner to be started up in case of emergency whilst the plant is running without the valve moving through the whole travel range
- Permanent storage of all parameters in non-volatile EEPROM
- Two-wire system with small load of 450 Ω at 20 mA
- Adjustable output pressure limitation
- Adjustable tight-closing function
- Constant monitoring of zero point
- Temperature sensor and operating hours counter integrated
- Self diagnostics; messages according to NAMUR Recommendation NE 107 or optionally issued using an analog position transmitter
- Integrated EXPERTplus diagnostics (see T 8388 EN), suitable for valves for throttling and on/off service, with additional partial stroke test for valves in safety-related applications
- Certified according to IEC 61508/SIL
Safety shutdown at 0 mA or 3.85 mA



Versions

Electropneumatic positioner with LCD, operable on site, local communication over SSP interface, diagnostic functions

- **Type 3731-3 EXPERTplus** · Positioner, communication using HART® protocol, diagnostic functions

Additional options

- Binary contact, output acc. to NAMUR (EN 60947-5-6) or directly to PLC, configurable as a limit switch or fault alarm output
- Binary input
- Analog position transmitter with two-wire transmitter
- Forced venting function (solenoid valve function)

Principle of operation

The electropneumatic positioner is attached to pneumatic control valves. It is used to assign the valve stem position (controlled variable x) to the input signal (reference variable w). The input signal received from a control system is compared to the travel or rotational angle of the control valve, and a pneumatic signal pressure (output variable y) is produced.

The positioner consists of a travel sensor system (2) proportional to resistance, an analog i/p converter with a downstream booster and the electronics unit with microcontroller (5).

When a deviation occurs, the actuator is pressurized or vented. The signal pressure to the actuator can be limited by software to 1.4, 2.4 or 3.7 bar.

A constant air stream to the atmosphere is created by the flow regulator (9) with a fixed set point. The air stream is used to purge the inside of the housing as well as to optimize the air capacity booster. The i/p module (6) is supplied with a constant upstream pressure by the pressure regulator (8) to make it independent of the supply air pressure.

Operation also in hazardous areas

The rotary pushbutton and display are accessible without having to open the positioner housing. As result, the positioner is still fully operable under hazardous area conditions.

The positioner is operated with a user-friendly rotary pushbutton. The parameters are selected by turning the knob, pushing it activates the required setting. In the menu, all parameters are listed in one level, meaning there is no need to search in submenus. All parameters can be checked and changed on site.

All values are displayed on the LCD. The reading direction of the LCD can be rotated by 180° at the push of a button.

The SAMSON configuration software, TROVIS-VIEW, can be used to configure the positioner. For this purpose, the positioner is equipped with an additional digital interface to be connected to the RS-232 interface of a PC.

All the parameters can be accessed over HART® communication.

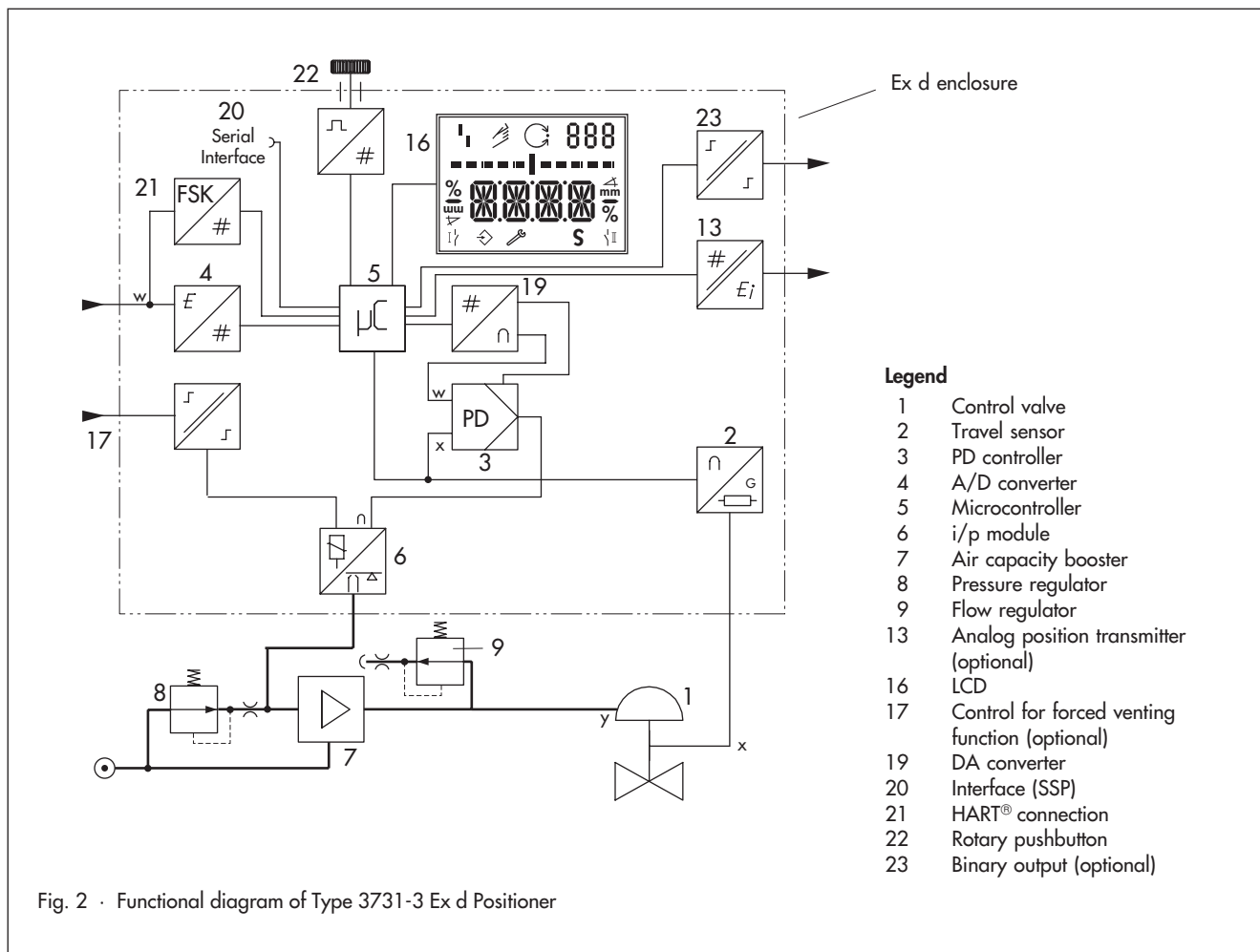

Table 1 · Technical data

Type 3731-3 Positioner	
Rated travel, adjustable	Direct attachment to Type 3277: 3.6 to 30 mm Attachment according to IEC 60534-6-1: 3.6 to 200 mm Attachment to rotary actuators: 24 to 100° opening angle
Travel range adjustable	Within the initialized travel/angle of rotation; restricted to 1/5 at the maximum
Reference variable w	Signal range: 4 to 20 mA · Two-wire device, polarity insensitive · Minimum span 4 mA Static destruct. limit: 40 V · Internal current limit 60 mA
Use in safety-instrumented systems in compliance with IEC 61508	Suitable for use in safety-relevant applications up to SIL 2 (single device) and SIL 3 (with redundant configuration). Type 3731-3xxxxx0...: Safety shutdown at a reference variable of 0 mA Type 3731-3xxxxx1...: Safety shutdown at a reference variable ≤ 3.85 mA
Minimum current	3.6 mA for LCD · 3.8 mA for operation Load impedance ≤ 9 V corresponding to 450 Ω at 20 mA
Communication	
Local communication	SAMSON SSP interface and serial interface adapter
Software requirements (SSP)	TROVIS-VIEW with database module 3731-3
HART® communication	HART® Field Communication protocol Impedance in HART® frequency range: Receiving approx. 455 Ω, sending approx. 185 Ω
Software requirements (HART®)	For handheld terminal: Device Description for Type 3731-3 For PC: DTM file certified according to specification 1.2, suitable for integrating the device into frame applications that support the use of FDT/DTM (e.g. PACTware); Integration into AMST™ Suite possible
Supply air	Supply pressure: 1.4 to 6 bar (20 to 90 psi) Air quality acc. to ISO 8573-1 (2001): Max. particle size and density: Class 4 · Oil content: Class 3 Pressure dew point: Class 3 or at least 10 K below the lowest expected ambient temperature
Signal pressure (output)	0 bar up to capacity of supply pressure · Can be limited by software to 1.4 bar/2.4 bar/3.7 bar ± 0.2 bar
Characteristics	Linear/equal percentage/reverse equal percentage Butterfly valve, rotary plug valve or segmented ball valve: Linear/equal percentage User-defined: Set in the operating software
Deviation	≤ 1 %
Hysteresis	≤ 0.3 %
Sensitivity	≤ 0.1 %
Transit time	Supply air and exhaust air adjustable separately over software by up to 240 sec.
Direction of action	Reversible
Air consumption, steady-state	Independent of supply air 110 l _n /h
Air output capacity	Actuator pressurized: At Δp = 6 bar: 8.5 m _n ³ /h · At Δp = 1.4 bar: 3.0 m _n ³ /h · K _{Vmax} (20 °C) = 0.09 Actuator vented: At Δp = 6 bar: 14.0 m _n ³ /h · At Δp = 1.4 bar: 4.5 m _n ³ /h · K _{Vmax} (20 °C) = 0.15
Permissible ambient temperature	-40 to +80 °C The limits specified in the EC Type Examination Certificate additionally apply.
Influences	Temperature: ≤ 0.2 %/10 K Supply air: None Vibrations: ≤ 0.25 % up to 2000 Hz and 4 g acc. to IEC 770
Electromagnetic compatibility	Complies with EN 61000-6-2, EN 61000-6-3 and NAMUR Recommendation NE 21 requirements
Electrical connections	Two threaded connections ½ NPT or optionally M20 x 1.5, screw terminals for 2.5 mm ² wire cross-section
Degree of protection	IP 66 / NEMA 4X
Explosion protection	
	ATEX: Ⓔ II 2 G EEx d IIC T6, T5 or T4/ EEx de IIC T6, T5 or T4 / II 2 D IP 65 T 80 °C FM/CSA: XP/I/1/BCD/T4...T6; XP/I/1/IIB + H ₂ /T4...T6; Type 4X/IP 66
Materials	
Enclosure	Die-cast aluminum EN AC-ALSi10Mg (Fe) (EN AC-43400) acc. to DIN 1706 Chromated and powder paint coated
External parts	Stainless steel 1.4301/1.4305/1.4310
Weight	Approx. 2.5 kg

Optional binary output	Software limit switch or fault alarm output galvanically isolated, optionally NAMUR EN 60947-5-6 or PLC	
Switching state	Terminals B-C Switching output AC/DC (PLC)	Terminals A-B
	Conducting / residual voltage < 1.7 V	Non-conducting / ≥ 2.1 mA
	Non-conducting / high resistance, $I < 100 \mu\text{A}$	Conducting / ≤ 1.2 mA
Operating voltage	Switching capacity: 40 V DC / 28 V AC / 0.3 A Static destruction limit: 45 V DC / 32 V AC / 0.4 A	Only for connection to NAMUR switching amplifiers acc. to EN 60947-5-6
Optional binary input	Galvanically isolated · Switching behavior configurable	
Active switching behavior		
Connection	For external switch (floating contact)	
Electrical data	Open-circuit voltage when contact is open: max. 10 V Pulsed DC current reaching peak value of 100 mA	
Contact	Closed	"On" switching state
	Open	"Off" switching state
Passive switching behavior		
Connection	For externally applied DC voltage, reverse polarity protection	
Electrical data	0 to 24 V, destruction limit 40 V, input resistance 6.5 k Ω	
Voltage	> 6 V	"On" switching state
	< 4 V	"Off" switching state
Optional forced venting	Galvanically isolated	
Input	0 to 40 V DC / 0 to 28 V AC, static destruction limit 45 V DC / 32 V AC, input resistance ≥ 7 k Ω	
Signal	Fail-safe position with input voltage ≤ 3 V	Normal operation with input voltage > 5.5 V
Optional analog position transmitter	Two-wire transmitter	
Auxiliary power	11 to 35 V DC, reverse polarity protection, static destruction limit 45 V DC	
Output signal	4 to 20 mA	
Direction of action	Reversible	
Working range	-1.25 to 103 % of the travel range, corresponding to 3.8 to 20.5 mA optionally also for fault alarm indication over 2.4 or 21.6 mA acc. to NAMUR Recommendation NE 43	
Characteristic	Linear	
Hysteresis and HF influence	Same as the positioner	
Other influencing variables	Same as the positioner	

Summary of explosion protection certificates

Type of approval	Certificate number	Date	Comments
EC Type Examination Certificate	PTB 05 ATEX 1058	2005-07-19	Ⓢ II 2 G EEx d IIC T6 Ⓢ II 2 G EEx de IIC T6 Ⓢ II 2 D IP 65 T 80 °C
IECEX	PTB 06.0041	2006-05-10	Ex d IIC T4-T6; II 2 D IP 65 T 80 °C; Type 3731-321
FM approval	3024956	2006-01-30	XP/I/1/BCD/T4 Ta=80 °C, T5 Ta=70 °C, T6 Ta=60 °C; Type 4X/IP 66 XP/I/1/IIB+H2/T4 Ta=80 °C, T5 Ta=70 °C, T6 Ta=60 °C; Type 4X/IP 66 DIP/II, III/1/EFG/T4 Ta=80 °C, T5 Ta=70 °C, T6 Ta=60 °C; Type 4X/IP 66 Class I, Division 1 and 2, Groups B, C, D Class II and III, Division 1 and 2, Groups E, F, G Class I, Zone 1, IIB + H2; Type 4X/IP 66
CSA approval	1709815	2005-10-04	Class 2258-02: Class I, Division 1 and 2, Groups B, C, D, T6...T4 Class II, Division 1 and 2, Groups E, F, G; Class III Class I, Zone 1, Group IIB+H2, T6...T4; Type 4X/IP 66
NEPSI approval	GYJ06172	2006-01-24	Ex d IIC T4-T6/Ex de IIC T4-T6; valid until 2011-01-23
GOST approval	B02563	2008-12-04	1 Ex d IIC T4/T6
JIS approval	TC17747	2006-09-12	Ex d IIC T6; Type 3731-327, valid until Sept. 2012

Dimensions in mm

Direct attachment

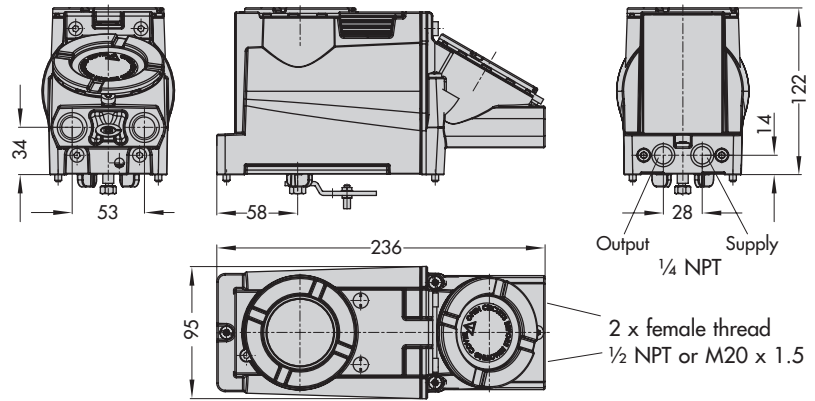

Attachment acc. to IEC 60534-6 and NAMUR

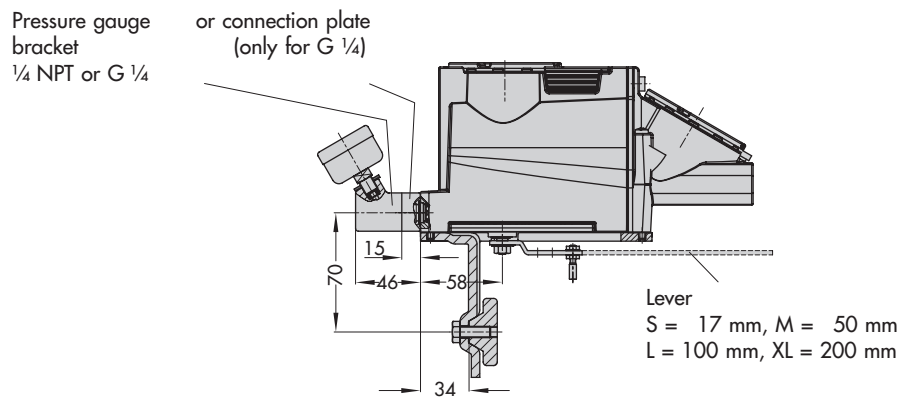

Attachment to rotary actuators

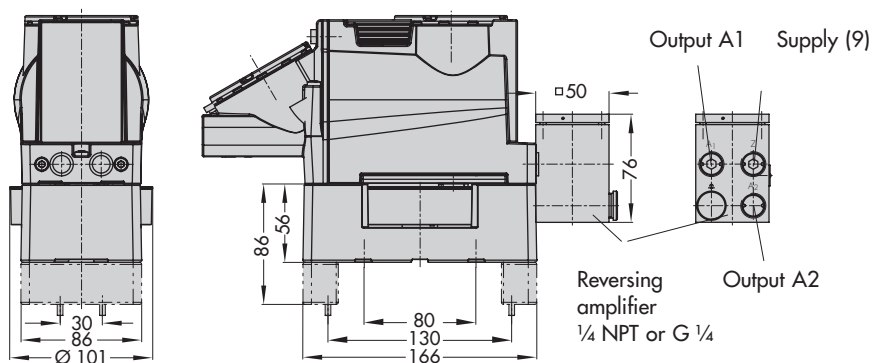

Article code

Positioner	Type 3731- 3													x	x	x	x	x	x	x	0	0	x	1	x	0	0	0
4 ... 20 mA, HART® communication, LCD, autotune																												
Explosion protection																												
II 2 G EEx d IIC T6/EEEx de IIC T6/II 2 D IP 65 T 80 °C acc. to ATEX	2	1																										
Ex d acc. to FM/CSA	2	3																										
Ex d acc. to JIS/Japan	2	7																										
Options																												
Without					0	0																						
Position transmitter					0	1																						
Binary input					0	3																						
Forced venting					0	5																						
Binary output (NAMUR/PLC)					0	6																						
Diagnostics																												
EXPERTplus										4																		
Electrical threaded connections																												
2x M20 x 1.5													1															
2x ½ NPT													2															
Shutdown behavior																												
Safety shutdown at 0 mA																					0							
Safety shutdown at 3.85 mA																					1							
Explosion-protection certificates																												
Same as specified under Explosion protection																										0		
NEPSI/China	2	1																								1		
IECEX	2	1																								2		
GOST/Russia	2	1																								3		
Special applications																												
None																											0	
Device compatible with paint (IP 41/NEMA 1)																											1	
Special version																												
None																											0	
																											0	
																											0	
																											0	

Positioner attachment

The Type 3731-3 Positioner can be attached directly to the Type 3277 Actuator, to control valves with cast yokes or rod-type yokes according to IEC 60534-6 (NAMUR) or to rotary actuators according to VDI/VDE 3845.

The mounting parts and accessories necessary are listed in the Mounting and Operating Instructions EB 8387-3 EN.

Direct attachment

The positioner can be attached directly to the Type 3277 Actuator with a connection block. In actuators with fail-safe action "Actuator stem extends" and Type 3277-5 Actuator (120 cm²), the signal pressure is transmitted over an internal bore in the actuator yoke to the actuator. In actuators with fail-safe action "Actuator stem retracts" and in actuators with effective diaphragm areas of 240 cm² or larger, the signal pressure is transmitted to the actuator over a ready-made external pipe connection.

Attachment according to IEC 60534-6 and NAMUR

Using the appropriate bracket, the positioner can also be attached to the yoke of control valves according to IEC 60534-6 (NAMUR recommendation). The positioner can be mounted on any side of the control valve.

Attachment to rotary actuators

The positioner is fitted with an adapter housing and spacers to attach it to rotary actuators according to VDI/VDE 3845. Another common mounting kit suitable for SAMSON Type 3278 Rotary Actuator and VETEC Types S160 and R Actuators is available.

Ordering text

Positioner Type 3731-3...

- With pneumatic connecting rail ISO 228/1-G ¼
- With/without pressure gauge for signal pressure indication
- Attachment to Type 3277 Actuator (120 to 700 cm²)
- Attachment according to IEC 60534-6-1 (NAMUR) travel: ... mm, stem diameter: ... mm, if applicable
- Attachment to Type 3278 Rotary Actuator (160 cm²)
- Attachment to rotary actuators acc. to VDI/VDE 3845
- Reversing amplifier for double-acting actuators with connection acc. to ISO 228/1 - G ¼ or ¼-18 NPT

Specifications subject to change without notice.

