

Application

Single-acting pneumatic rotary diaphragm actuator for butterfly valves and other final control elements with rotary closure members

Maximum opening angle $\varphi = 93^\circ$

The Type BR 30a Pneumatic Rotary Actuators are equipped with a rolling diaphragm and a central return spring.

Special features

- Effective diaphragm areas from 600 to 1300 cm²
 - Torques from 15 to 5619 Nm
 - Signal pressure up to max. 6 bar
 - Various bench ranges possible through continuously adjustable spring compression or variation of the springs
 - No special tools needed to change the bench range
 - Direction of action (spring opens/closes) depends on attachment to the valve
 - Externally adjustable stop screws to limit the opening angle
 - For continuous operation at temperatures from -35 to 90 °C
- Attachment of positioner, limit switch, solenoid valve, and other accessories possible

Versions

Standard version · Pneumatic rotary actuator for opening angles of $\varphi = 93^\circ \pm 3^\circ$ with effective diaphragm areas of 60, 105, 240, 470, 780 or 1300 cm²

Type BR 30a (Fig. 1) · Maximum signal pressure 3.5 bar (with spring 1) or

Type BR 30a (Fig. 1) · Maximum signal pressure 6 bar (with spring 2)

Further versions with

- Additional manual override
- Double diaphragm for very high torques



Fig. 1 · Type BR 30a Rotary Diaphragm Actuator



Fig. 2 · Type BR 30a Rotary Diaphragm Actuator with Type BR 14a Butterfly Valve, positioner, and solenoid valve

Principle of operation (Fig. 3)

The signal pressure generates the force $F = p_{st} \cdot A$ at diaphragm surface A (2). This force opposes the force of the compression spring (4) in the actuator. In this process, the linear diaphragm travel H is transmitted to the actuator shaft (13) over the actuator stem (3) and the levers (11 and 12), where it is converted into a rotary motion. The upper and lower limits of the opening angle can be adjusted using the two externally accessible stop screws (14).

The travel H is proportional to the signal pressure p_{st} . The signal pressure range is determined by the spring rate and the spring compression, which can be modified within a wide range by turning the threaded rod (7). Each actuator size is by default equipped with two different springs. Spring 1 can be used for pressures up to 3.5 bar, spring 2 up to max. 6 bar.

The valve can be attached to either end of the shaft (13). Both connections are designed as a square socket according to DIN/ISO 5211. The connection determines the actuator's fail-safe action:

Fail-safe action "Spring closes"

The compression spring (4) closes the valve when the diaphragm is relieved of pressure or when the supply air fails. The valve is opened against the force of the spring when the signal pressure increases.

Fail-safe action "Spring opens"

The compression spring (4) opens the valve when the diaphragm is relieved of pressure or when the supply air fails. The valve is closed against the force of the spring when the signal pressure increases.

Torque characteristic curve (Fig. 4)

The characteristic of torque is determined by the lever design. Fig. 4 illustrates a typical example. The diagram plots the air torque M_{dL} and the spring torque M_{dF} versus the actuator's opening angle φ for a certain actuator size. The air torque results from increasing the signal pressure p_{st} against the spring force; the spring torque results from $p_{st} = 0$, when the spring is relieved from its rest position.

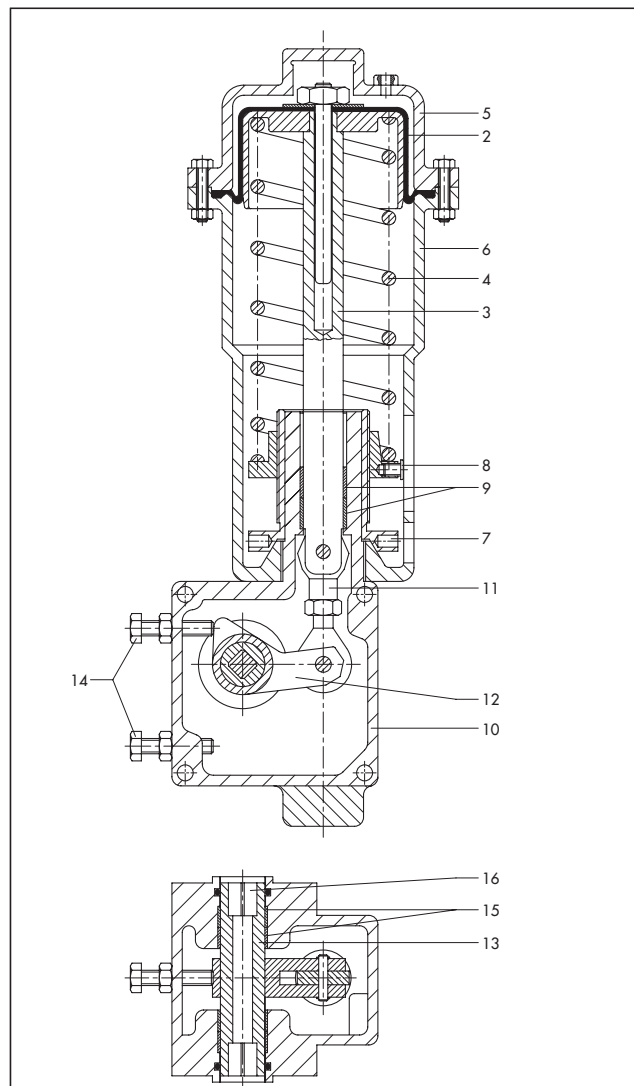

Fig. 3 · Pfeiffer Type BR 30a Rotary Actuator

Legend to Fig. 3

- 1 Signal pressure connection
- 2 Rolling diaphragm
- 3 Actuator stem
- 4 Compression spring
- 5 Cover
- 6 Actuator housing
- 7 Threaded rod
- 8 Spring plate
- 9 Friction bushing
- 10 Crankcase
- 11 Lever
- 12 Lever
- 13 Actuator shaft
- 14 Stop screws
- 15 Bearing bushings
- 16 O-ring

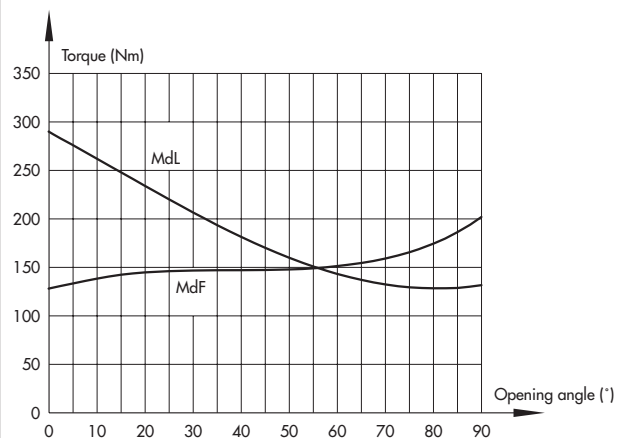

Fig. 4 · Example illustrating the torque characteristic
Actuator size 3 with spring 1 at 2.5 bar supply pressure

Table 1 · Technical data for Type BR 30a Rotary Diaphragm Actuator

BR 30a	Size	0	1	2	3	4	5	6
Effective diaphragm area	cm ²	60	105	125	240	470	780	1300
Travel	mm	55	60	90			120	
Opening angle	φ	90°						
Permissible temperature	°C	-35 to 90 °C						

Table 2 · Materials

Housing and cover	EN-JS1049 (GGG 40.3)
Rolling diaphragm	NBR (nitrile rubber) with fabric insert
Actuator stem	Stainless steel 1.4104
Actuator shaft	1.0570
Friction bearing	PTFE
O-ring	FPM (FKM)
Paint	PVC, black (RAL 9005)

Table 3 · Torques M_d in Nm for Type BR 30a Actuator

Actuator size	Supply pressure		2.5 bar	3 bar	3.5 bar	4 bar	4.5 bar	5 bar	5.5 bar	6 bar
	Spring 1/2		1	1	1	2	2	2	2	2
0	M _d air	Min.	16	21	27	24	29	34	42	52
		Max.	40	46	53	65	72	77	86	97
	M _d spring	Min.	15	21	25	24	29	34	36	36
		Max.	34	39	43	56	60	65	67	67
1	M _d air	Min.	40	57	76	56	67	83	101	120
		Max.	95	120	147	160	176	198	225	252
	M _d spring	Min.	40	42	42	56	67	72	72	72
		Max.	60	61	61	105	114	117	117	117
2	M _d air	Min.	59	77	95	84	102	121	139	170
		Max.	155	179	204	259	282	307	331	373
	M _d spring	Min.	59	77	95	83	102	121	139	139
		Max.	111	125	139	188	204	218	233	233
3	M _d air	Min.	129	173	233	160	197	234	269	306
		Max.	291	353	437	510	557	605	652	703
	M _d spring	Min.	128	149	149	160	197	233	269	302
		Max.	201	219	219	373	402	431	460	487
4	M _d air	Min.	249	319	389	380	451	521	592	705
		Max.	595	694	792	972	1068	1167	1265	1426
	M _d spring	Min.	249	319	389	279	451	521	592	600
		Max.	417	473	529	689	747	803	858	865
5	M _d air	Min.	570	734	894	798	966	1131	1294	1458
		Max.	1398	1629	1862	2352	2578	2807	3037	3268
	M _d spring	Min.	570	733	894	798	966	1130	1294	1457
		Max.	892	1013	1132	1546	1671	1794	1915	2037
6	M _d air	Min.	926	1235	1536	1601	1904	2205	2502	3011
		Max.	2464	2834	3211	3825	4199	4577	4957	5619
	M _d spring	Min.	926	1235	1535	1600	1903	2204	2502	2518
		Max.	2147	2427	2700	3294	3570	3842	4112	4127

Table 4 · Dimensions in mm and weights

BR 30a	Size	0	1	2	3	4	5	6
Diaphragm area	cm ²	60	105	125	240	470	780	130
∅ A		134	175	189	240	320	410	510
∅ B		90	114	120	150	187	244	250
C		364	453	550	570	713	989	1128
M		60	76	95	95	99	145	145
L		94	94	126	126	126	152	190
L1		100	100	132	132	132	160	200
L2		75	75	100	100	115	130	165
L3		40	40	56	56	56	80	90
α		R 1/4"	R 1/4"	R 1/4"	R 1/4"	R 3/8"	R 1/2"	R 1/2"
Connection according to DIN/ISO 3337		F04	F05	F07	F10	F12	F14	F16
SW (width across flats)		11	14	17	22	27	36	46
F		80	80	80	130	130	130	80
G		30	30	30	30	30	30	30
H		30	30	30	30	30	30	30
VDI/VDE		2	2	2	3	3	3	2
Weight	kg	10	16	22	30	62	120	190

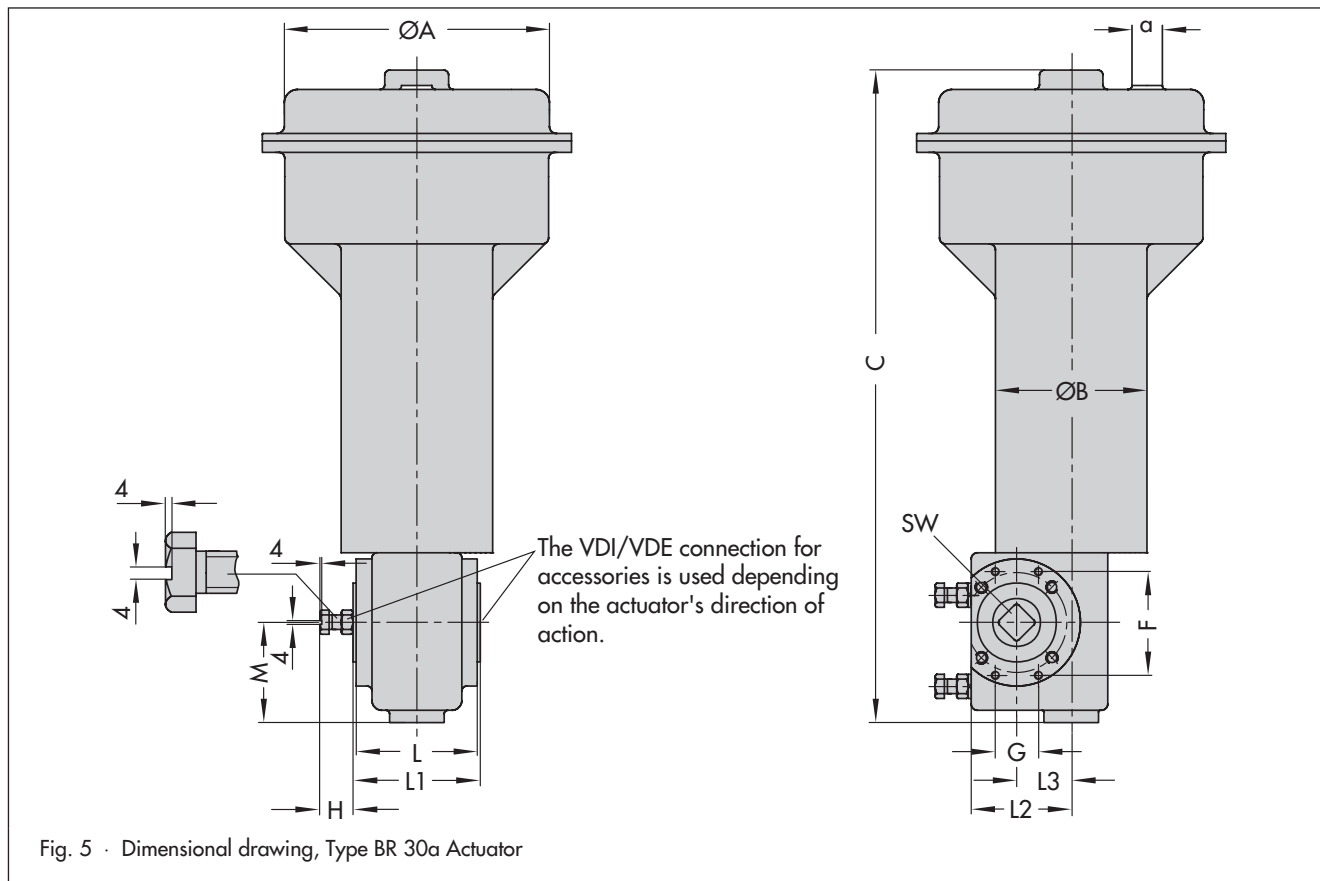

Fig. 5 · Dimensional drawing, Type BR 30a Actuator

Ordering text

Pneumatic actuator	Type BR 30a	Accessories	Positioner, limit switch, and/or solenoid valve
Size	0 to 6 (see Table 3) or	Optionally, special version	
Diaphragm area	... cm ²		
Max. signal pressure bar		

Specifications subject to change without notice.

