

PTFE-lined Tank Bottom Valve

Pfeiffer Type BR 21a



Application

Tight-closing tank bottom valve lined with PTFE for corrosive media, especially designed for demanding applications in chemical plants.

Nominal size DN 50 to DN 150
Nominal pressure PN 10/16
Temperatures -10 to 200 °C

PTFE-lined tank bottom valve optionally equipped with:

- Pneumatic actuator or
- Lever

Valve body made of:

- Spheroidal graphite iron with isostatic lining made of white PTFE

Ball material:

- Stainless steel encapsulated in PTFE

Further features

- TA-Luft (German clean air act) equivalent certification
- Exchangeable PTFE seat rings
- Ball shaft sealed by a spring-loaded PTFE V-ring packing

The ball valves fitted with a pneumatic actuator can be equipped with positioner, solenoid valve and other devices in accordance with VDI/VDE 3845.

Versions

Standard version · Pfeiffer Type BR 21a PTFE-lined Tank Bottom Valve, nominal pressure PN 10/16 with the following nominal sizes:

Inlet DN	65	100	100	150	150
Outlet DN	50		80		100

- **Type BR 21a** · With pneumatic actuator with or without fail-safe action
- **Type BR 21a** · With lever (Fig. 1)

Further versions

- Lining with special PTFE compounds
- Conductive PTFE lining
- Ball shaft sealing with two V-ring packings and test connection
- Connecting flanges according to ANSI Class 150 on request
- Grooved flange according to DIN 2512
- Various ball and sealing ring materials
- Heating jacket

Note: Prior to using the tank bottom valve in hazardous areas, refer to the maintenance instructions BA 20a concerning its use according to ATEX 94/9/EC.



Fig. 1 · Type BR 21a Tank Bottom Valve

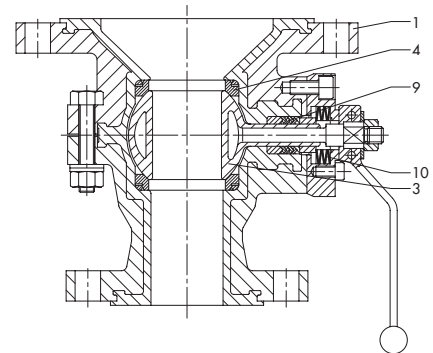

- 1 Body
- 3 Ball
- 4 Seat ring
- 9 V-ring packing
- 10 Belleville spring washers

Fig. 2 · Sectional diagram of Type BR 21a Tank Bottom Valve

Principle of operation (Fig. 2)

The larger flange of the Type BR 21a Tank Bottom Valve is bolted onto the bottom flange of the tank. The ball (3) with its cylindrical bore (ball channel) rotates around the center axis. The rotary angle of the ball determines the flow rate across the free area between the body (1) and the ball channel. The ball shaft, which is guided to the valve exit, is equipped with a manually operated lever. Optionally it can be connected to a pneumatic rotary actuator over an adapter.

The ball (3) is sealed in the PTFE-lined body by means of exchangeable seat rings (4). The ball shaft is sealed by a maintenance-free PTFE V-ring packing (9) which is live-loaded by Belleville spring washers (10) located above the packing.

Pressure-temperature diagram

The differential pressures specified are limited by the pressure-temperature diagram. Should the actual differential pressures be located above the curve, please contact us for further advice.

Fail-safe position

Depending on the version of the single-acting rotary actuator, the ball valve has two fail-safe positions which become effective when the actuator is relieved of pressure as well as when the supply air fails:

Control valve CLOSED without supply air

The ball valve closes when the supply air fails.

Control valve OPEN without supply air

The ball valve opens when the supply air fails.

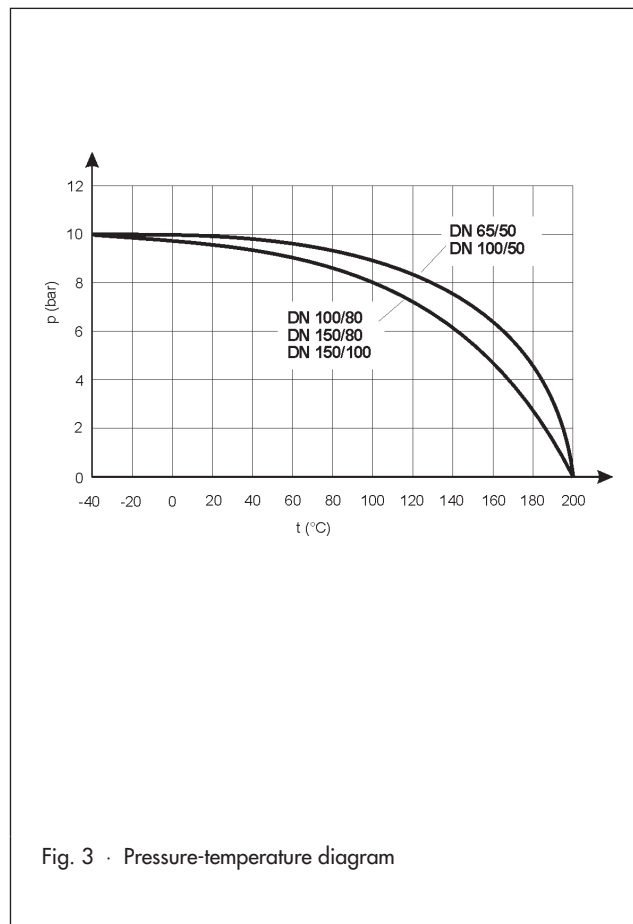

Table 1 · Technical data for Type BR 21a

Nominal size	Inlet	DN 65	DN 100	DN 100	DN 150	DN 150
	Outlet	DN 50	DN 50	DN 80	DN 80	DN 100
Nominal pressure	PN 10/16					
Temperature range	See Pressure-Temperature diagram					
Ball sealing	White PTFE					
Leakage acc. DIN EN 12266-1	Test P12, leakage rate "A"					
Flanges	Acc. to DIN 2632/2633 or ANSI Class 150					
Packing	PTFE V-ring packing loaded by Belleville spring washers					

Table 2 · Materials

Body	EN-JS1049 (GGG 40.3) with PTFE lining
Ball	1.4313/1.4317 encapsulated by PTFE
Seat rings	White PTFE
Packing	PTFE V-ring packing · Springs made of spring steel 1.8159, Delta Tone coated
Bearing bushing	PTFE with 25 % carbon
Outer coating	Black PVC (RAL 9005)



SAMSON AG · MESS- UND REGELTECHNIK
Weismüllerstraße 3 · 60314 Frankfurt am Main · Germany
Phone +49 69 4009-0 · Fax +49 69 4009-1507
Internet: <http://www.samson.de>

T 9931 EN