

## System 6000

# Elektropneumatic Converters for Direct Current Signals

## i/p Converter Type 6111



### Application

Instruments used to convert direct current input signals into pneumatic output signals for measuring and control tasks. Especially suitable as intermediate element between electric measuring devices and pneumatic controllers (or between electric control devices and pneumatic control valves).



These devices are designed for use in all kinds of industrial applications, especially in the field of process engineering.

Both signal converters accept a load-independent 4 to 20 mA or 0 to 20 mA direct current input signal which they convert into a pneumatic output signal.

Wide output pressure ranges can be selected for the Type 6111 i/p Converter by installing various converter modules (see "Technical data"). The maximum output pressure to be achieved is 8 bar (120 psi).

### Special features include:

- Wide selection of measuring ranges
- High output pressures up to 8 bar (120 psi)
- Easy replacement of i/p module
- Zero reset at specific mA-value when switch-off function is enabled in the electronics (function can be activated as required)
- Plastic case
- Operation possible without an upstream pressure regulator
- Supply air distributor optionally available as accessory for 3, 4, 5 and 6 converter modules (Fig. 3)

### Versions

**Type 6111** (Fig. 1) · i/p Converter, designed for snap-on mounting on a top-hat rail



Fig. 1 · Type 6111 i/p Converter

**Principle of operation (Fig. 2)**

Electropneumatic signal converters essentially consist of an i/p converter module operating according to the force-balance principle and a connected volume booster.

When operated, the supplied direct current (4) flows through the plunger coil (2) in the field of the permanent magnet (3). At the balance beam (1), the force of the plunger coil, which is proportional to the current, is balanced against the force of the back-pressure. The back-pressure is produced on the flapper plate (6) by the air jet leaving the nozzle (7).

The nozzle is supplied with air from the pneumatic output (36). With an input signal of 0 mA, an output pressure of approximately 50 to 80 mbar (0.7 to 1.2 psi) already exists due to the offset spring.

The supply air (9) flows in the lower diaphragm chamber, and a certain amount flows to the output. When the current increases, the flapper moves closer to the nozzle. The force of the resulting back-pressure pushes both the diaphragm (5) and sleeve (8) downwards, allowing additional air to enter the chamber. The passing air volume increases until the forces on the diaphragm obtain a state of equilibrium. When the current decreases, this action is reversed. The back-pressure caused by the nozzle and flapper decreases, and the diaphragm is pressed upwards. In this process, it releases the sleeve, if applicable, and opens the vent (11) until the forces on the diaphragm are balanced again.

Devices with an input signal range from 4 to 20 mA have a slide switch which activates the switch-off electronic function. This function causes the pneumatic output to be vented up to approx. 100 mbar (1.4 psi) when the input signal falls below 4.08 mA ± tolerance. In this way, the tight shut-off function of a valve can be guaranteed.

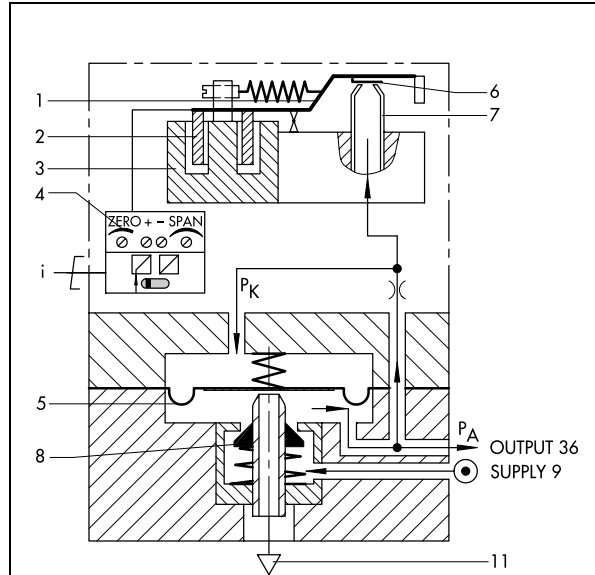

- |                    |              |
|--------------------|--------------|
| 1 Balance beam     | 7 Nozzle     |
| 2 Plunger coil     | 8 Sleeve     |
| 3 Permanent magnet | 9 Supply air |
| 4 Input            | 11 Vent      |
| 5 Diaphragm        | 36 Output    |
| 6 Flapper plate    |              |

Fig. 2 · Functional diagram



Fig. 3 · Supply air distributor for Type 6111

## Technical data

(Conversion: bar x 14.5 = psi and m<sup>3</sup>/h x 35.3 = ft<sup>3</sup>/h (cfh))

<b>Type</b>	<b>6111 i/p Converter</b>		
<b>Input</b>	4 to 20 mA, (optionally 0 to 20 mA), for split ranges from 4 to 12 or 12 to 20 mA; other signals on request		
Load	Standard Ex-proof versions Devices w/o switch-off electronics	≤ 6V (corresponds to 300 Ω at 20 mA) 7 V ( corresponds to 350 Ω at 20 mA) ≤ 4 V (corresponds to 200 Ω at 20 mA)	
Explosion protection	Type 6111-1: EEx ia II C		
<b>Output</b>	0.2 to 1 bar (3 to 15 psi) (standard range) 0.4 to 2 bar (6 to 30 psi) (standard range) Special ranges adjustable as per customer demand: Lower range value    Span    Δp 0.1 to 0.4 bar; 0.75 to 1.0 bar 0.1 to 0.4 bar; 1.0 to 1.35 bar 0.1 to 0.4 bar; 1.35 to 1.81 bar 0.1 to 0.8 bar; 1.81 to 2.44 bar 0.1 to 0.8 bar; 2.44 to 3.28 bar 0.1 to 0.8 bar; 3.28 to 4.42 bar 0.1 to 1.2 bar; 4.42 to 5.94 bar 0.1 to 1.2 bar; 5.94 to 8.0 bar		
	Maximum air output	2.0 m <sup>3</sup> /h at output 0.6 bar (0.2 to 1.0 bar) 2.5 m <sup>3</sup> /h at output 1.2 bar (0.4 to 2.0 bar) 8.5 m <sup>3</sup> /h at output 5.0 bar (0.1 to 8.0 bar)	
<b>Supply air</b>	Minimum 0.4 bar (6 psi) above the upper range value Maximum 10 bar (145 psi) without upstream pressure regulator		
	Air consumption	0.08 mn <sup>3</sup> /h at 1.4 bar;    2.8 Sft <sup>3</sup> /h (Scfh) at 21 psi 0.10 mn <sup>3</sup> /h at 2.4 bar;    3.5 Sft <sup>3</sup> /h (Scfh) at 36 psi Maximum 0.26 mn <sup>3</sup> /h at 10 bar    Max. 9.2 Sft <sup>3</sup> /h (Scfh) at 145 psi	
<b>Characteristic<sup>1)</sup></b>	Output linear to input		
	Hysteresis	≤ 0.3 % of upper range value	
	Deviation from terminal-based conformity	≤ 1 % of upper range value	
	Influence in % of final value	Supply: 0.1 %/0.1 bar	
		Alternating load, supply failure, interruption of the input current: < 0.3 %	
		Ambient temperature: Lower range value < 0.03 %/°C, measuring span < 0.03 %/°C	
Dynamic response	With an output from 0.2 to 1 bar (3 to 15 psi)		
	Limiting frequency	5.3 Hz	
	Phase shift	-130°	
Variable position	Maximum 3.5 % depending on the attachment, ± 1 % when horizontal		
<b>Ambient conditions, degree of protection, weight</b>			
	Ambient temperature	-20 to +70 °C (-4 to +160°F)	
	Storage temperature	-40 to +70 °C (-40 to +160°F)	
	Degree of protection	IP 20	
	Weight	approx.	0.35 kg (0.77 lb)
<b>Materials</b>			
	Enclosure	Polyamide (nylon) reinforced with glass fibre	

<sup>1)</sup> Measured according to IEC 770

### List of ex-proof certificates issued for Type 6111-1

Type of certificate	Certificate number	Date	Comments
Certificate of conformity	PTB-Nr. Ex-96.D.2196	24/01/1997	EEx ia II C T6

The certificates are included in the "Mounting and operating instructions", or they can be ordered from the manufacturer.

### Electrical connection

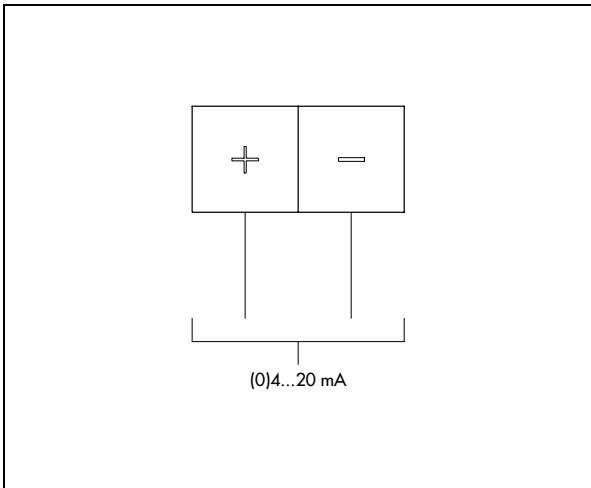

### Dimensions in mm

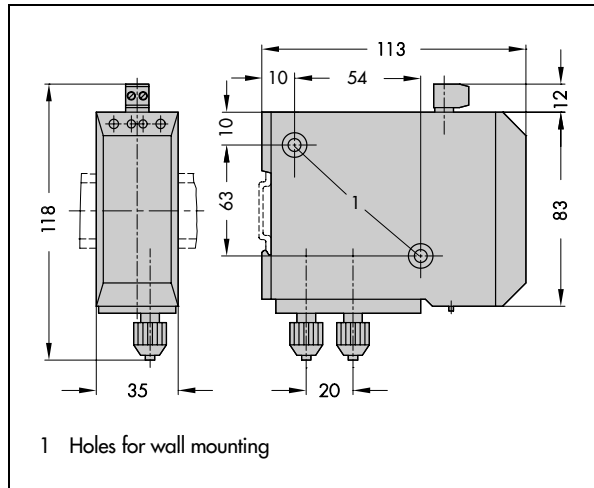

### Ordering details

#### i/p Converter

Without explosion protection

With explosion protection

Electric input

4 to 20 mA

0 to 20 mA

Pneumatic output

0.2 to 1 bar (3 to 15psi)

0.4 to 2 bar (6 to 30psi)

Special ranges adjustable acc. to customer requirements

Lower range value

Span

0.1 to 0.4 bar; 0.75 to 1.0 bar

0.1 to 0.4 bar; 1.0 to 1.35 bar

0.1 to 0.4 bar; 1.35 to 1.81 bar

0.1 to 0.8 bar; 1.81 to 2.44 bar

0.1 to 0.8 bar; 2.44 to 3.28 bar

0.1 to 0.8 bar; 3.28 to 4.42 bar

0.1 to 1.2 bar; 4.42 to 5.94 bar

0.1 to 1.2 bar; 5.94 to 8.0 bar

Operating direction

Increasing/increasing

Increasing/decreasing

Hose connection

NPT 1/8"

G 1/8

M 5

Type 6111-□□□□

0

1

1

2

0

1

2

3

4

5

6

7

8

9

1

2

0

1

2

3

### Assembly

Units designed for snap-on mounting on a top-hat rail according to DIN EN 50 022, 35 mm width.

Wall mounting option, holes with  $\varnothing 5.5$ , see dimensional drawing (1)

Air connections (supply air and output): hose connection for hose 4 x 1 (external diameter 6 mm)

Electrical connection: Terminals for leads 0.5 to 2.5 mm<sup>2</sup>

### NOTE:

When using a plug-on terminal, the connections marked "+" and "-" on the front panel of the device are insignificant.

### Ordering text

Type 6111-.... i/p Converter (specify relevant data under "Ordering details")



SAMSON CONTROLS INC.  
1 - 105 Riviera Drive  
Markham · Ontario · Canada · L3R 5J7  
Tel. (905) 474-0354 · Telefax (905) 474-0998  
Internet: <http://www.samsoncontrols.com>

SAMSON CONTROLS INC.  
4111 Cedar Boulevard  
Baytown · Texas · USA · 77520-8588  
Tel. (281) 383-3677 · Telefax (281) 383-3690  
Internet: <http://www.samson-usa.com>

T 6111

T 6111 CA