

## Electropneumatic Converter for Direct Current Signals

### i/p Converter Type 6126

#### Application

Devices used to convert a direct current signal into a pneumatic signal for measure and control. Especially suitable as intermediate element between electrical measuring devices and pneumatic controllers or between electrical control devices and pneumatic control valves.



The signal converter accepts a load-independent (0)4 to 20 mA direct current signal or a (0)2 to 10 V voltage signal.

Depending on the supply air pressure, the converter provides a pneumatic output signal of 0.2 to 1 bar (3 to 15 psi) or 0.4 to 2 bar (6 to 30 psi). The i/p converter is available with two different i/p modules Type 6109 or 6112. The Type 6112 model offers further output signal ranges (see "Technical data").

#### Special features

- Small dimensions, low weight and robust housing
- Excellent dynamic response
- Relatively large air output with low air supply consumption
- Output pressure up to 8 bar (120 psi)
- Central venting
- Low vibration influences
- Versions with reversed characteristic are available (only i/p module Type 6112)
- Option of connecting a pressure gauge parallel to the output
- Operation possible without an upstream pressure regulator
- Zero reset at a specific mA value when a venting function (switch-off) is enabled (function can be activated as required)
- For electronic devices, zero and span can be adjusted via potentiometers

#### Versions

For use in **non-hazardous areas**:

**Type 6126-0** with electronics, i. e. switch-off electronic and potentiometer for zero and span

**Type 6126-0** without electronics



Fig. 1 · Type 6126 i/p Converter with pressure gauge

## Principle of operation

The electropneumatic converter consists of an i/p module which operates according to the principle of force equilibrium and a downstream volume amplifier.

When operated, the supplied direct current (4) flows through the plunger coil (2) located in the field of a permanent magnet (3). At the balance beam (1), the force of the plunger coil which is in proportion to the current is balanced against the force of the dynamic back-pressure. The back-pressure is produced on the flapper plate (6) by the air jet leaving the nozzle (7).

The air supply (8) flows into the lower chamber of the volume amplifier. A certain amount of air determined by the position of the diaphragm reaches the sleeve (9) and flows to the output (36).

When the input current increases and as a result the force of the plunger coil increases too, the flapper moves closer to the nozzle. This causes the dynamic back-pressure and the cascade pressure  $p_k$  forming in front of the restrictor (8.2) to increase. The cascade pressure increases until it corresponds to the input current and pushes both the diaphragm (10) and the sleeve (9) downwards, causing the output pressure  $p_A$  to increase until a new state of equilibrium is reached in the diaphragm chambers. When the cascade pressure decreases, the diaphragm is pressed upwards and it releases the sleeve. The output pressure  $p_A$  escapes through the sleeve to the vent (EXHAUST) until the forces on the diaphragm are balanced again.

Converters with an input signal range from 4 to 20 mA are equipped with a slide switch which activates the switch-off electronic function. This function causes the pneumatic output to be vented up to approx. 100 mbar (1.45 psi) when the input signal falls below 4.08 mA  $\pm$  tolerance. This ensures tight shut-off of a valve.

## Nomenclature for ordering

Type	6126-	<input type="checkbox"/>	<input type="checkbox"/>	<input type="checkbox"/>	<input type="checkbox"/>	<input type="checkbox"/>	<input type="checkbox"/>	<input type="checkbox"/>
<b>Explosion protection</b>		1						
None		0						
<b>Pneumatic connection</b>								
1/4" NPT			1					
ISO 28/1- G1/4			2					
<b>Converter module</b>								
Type 6109				1				
Type 6112				2				
<b>Input</b>								
4 to 20 mA					1			
0 to 20 mA without electronics					2	2		
4 to 20 mA without electronics						3		
0 to 10 V, 24 V DC						4		
2 to 10 V, 24 V DC						5		
<b>Output</b>								
0.2 to 1 bar (standard)							1	
0.4 to 2 bar (standard)						2	2	
Special range up to 8 bar <sup>1)</sup>						2	3	
3 to 5 psi							4	
6 to 30 psi						2	5	
Special ranges up to 116 psi <sup>1)</sup>						2	6	
<b>Degree of protection (housing)</b>								
IP 54							0	
IP 65							1	
<b>Pressure gauge</b>								
Without								0
With								1
<b>Operating direction</b>								
Increasing/increasing								0
Increasing/decreasing					2			1

<sup>1)</sup> Please indicate range, see technical data

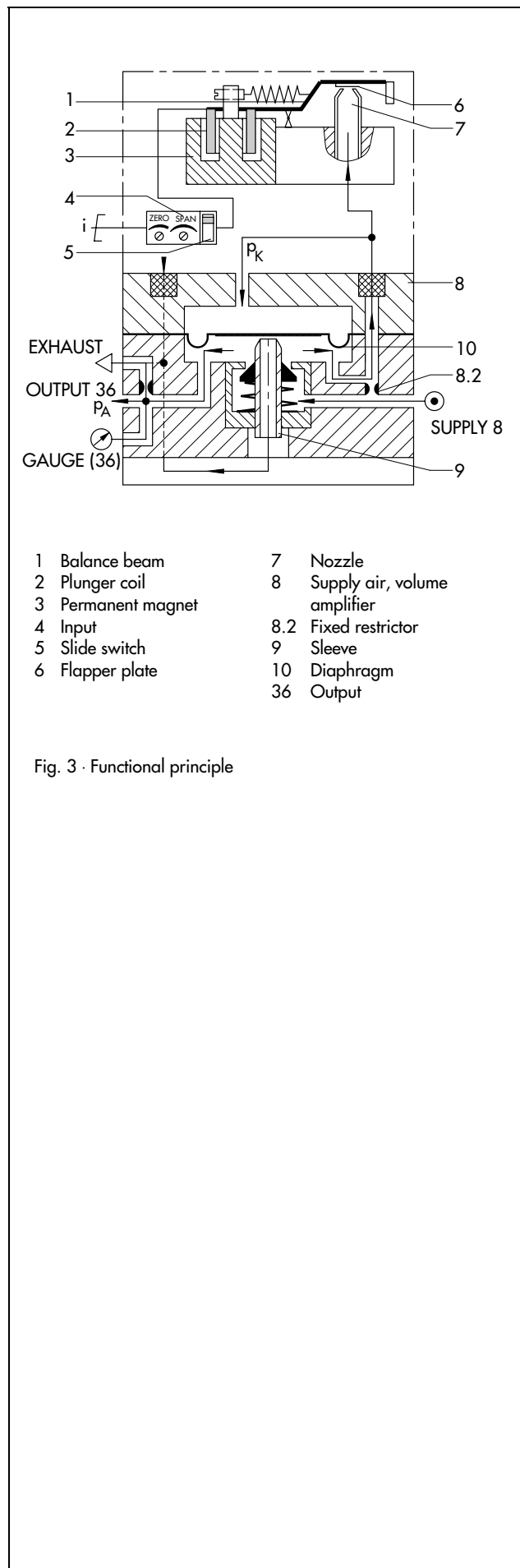

Fig. 3 · Functional principle

**Table 1 · Technical data**(Conversion: bar x 14.5 = psi and m<sup>3</sup>/h x 35.3 = ft<sup>3</sup>/h (cfh))

Type	Without explosion protection	Type 6126-0
Input		(0)4 to 20 mA; 0(2) to 10 V with 24 V DC auxiliary power; other signals available on request. Minimum current > 3.6 mA; load ≤ 6V (corresponds to 300 Ω at 20 mA).
Output		0.2 to 1 bar (3 to 15 psi) (i/p module Types 6109 and 6112) 0.4 to 2 bar (6 to 30 psi) (i/p module Type 6112) Special ranges: (Type 6112) Lower range value                      Span Δp 0.1 to 0.4 bar;                      0.75 to 1.0 bar 0.1 to 0.4 bar;                      1.0 to 1.35 bar 0.1 to 0.4 bar;                      1.35 to 1.81 bar 0.1 to 0.8 bar;                      1.81 to 2.44 bar 0.1 to 0.8 bar;                      2.44 to 3.28 bar 0.1 to 0.8 bar;                      3.28 to 4.42 bar 0.1 to 1.2 bar;                      4.42 to 5.94 bar 0.1 to 1.2 bar;                      5.94 to 8.0 bar
	Air output capacity <sup>2)</sup>	2.0 m <sup>3</sup> /h at output 0.6 bar (0.2 to 1.0 bar) 2.5 m <sup>3</sup> /h at output 1.2 bar (0.4 to 2.0 bar) 8.5 m <sup>3</sup> /h at output 5.0 bar (0.1 to 8.0 bar)
Supply air		Minimum 0.4 bar (6 psi) above the upper range value, maximum 10 bar (145 psi) without upstream pressure regulator
	Air consumption <sup>1)</sup>	0.08 m <sup>3</sup> /h at 1.4 bar    2.8 Sft <sup>3</sup> /h (Scfh) at 21 psi 0.1 m <sup>3</sup> /h at 2.4 bar    3.5 Sft <sup>3</sup> /h (Scfh) at 36 psi Maximum 0.26 m <sup>3</sup> /h at 10 bar    Max. 9.2 Sft <sup>3</sup> /h (Scfh) at 145 psi
Characteristic		Output linear to input
	Hysteresis	≤ 0.3 % of upper range value; more accurate values on request
	Deviation from terminal-based conformity	≤ 1 % of upper range value; more accurate values on request
	Effect in % of upper range value	Supply air: 0.1 %/0.1 bar <sup>1)</sup> (0.1%/1.5 psi <sup>1)</sup> )
		Alternating load, supply air failure, interruption of the input current: < 0.3 %
		Ambient temperature: lower range value < 0.02 %/°C, span < 0.03 %/°C
Dynamic response <sup>3)</sup>		
	Limiting frequency	5.3 Hz
	Phase shift	-130 °
Effect of variable mounting position		Maximum 3.5 % depending on attachment; ± 1 % when horizontal (with Type 6109) Maximum 1 % depending on the attachment; ± 0.3 % when horizontal (with Type 6112)
Ambient conditions, degree of protection, weights		
	Ambient temperature	-25 to +70 °C (-13 to 160°F)
	Degree of protection	IP 54/IP 65
	Weights                      approx.	0.6 kg (1.3 lb)
Materials		
	Housing	Die-cast aluminum, chromized, plastic coated/glass-fiber reinforced polyamide
	Other parts	Non-corrosive material

1) Measured at medium output pressure

2) Measured with 2m hose 4 x 1

3) Measured according to IEC 770

**Installation**

The converter can be mounted to a wall, tube or directly to the control valve. The mounting bracket for wall mounting is included in the scope of supply.

Install the converter in horizontal position, with the pressure gauge (or screw plug) facing upwards. If a different mounting

position is required, zero must be corrected for devices with electronics, using the ZERO adjuster.

**Ordering text**

See nomenclature.

Optional accessories for mounting to tubes/control valves.

## Electrical connection

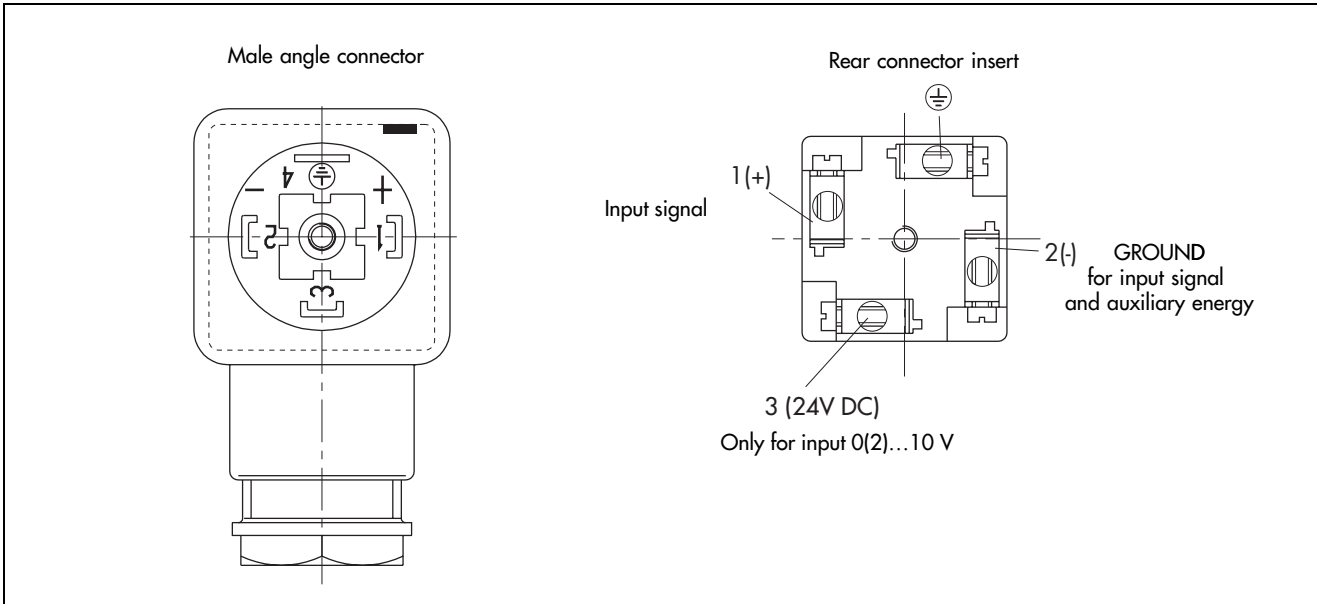

## Dimensions in mm

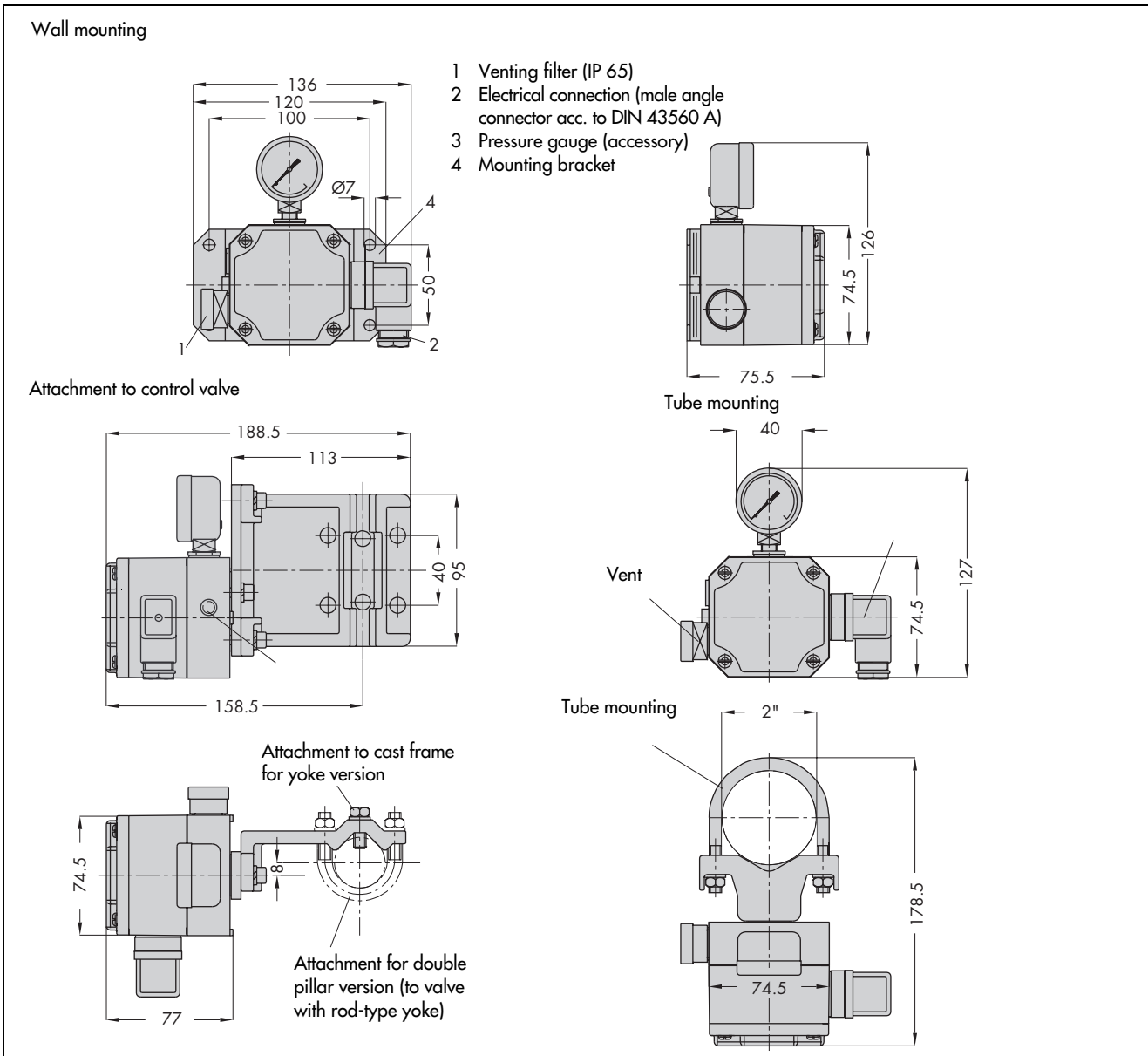

SAMSON CONTROLS INC.  
1 - 105 Riviera Drive  
Markham · Ontario · Canada · L3R 5J7  
Tel. (905) 474-0354 · Telefax (905) 474-0998  
Internet: <http://www.samsoncontrols.com>

SAMSON CONTROLS INC.  
4111 Cedar Boulevard  
Baytown · Texas · USA · 77520-8588  
Tel. (281) 383-3677 · Telefax (281) 383-3690  
Internet: <http://www.samson-usa.com>

**T 6126**

T 6126 CA