



Application

Rack-mounting units designed to convert dc signals into pneumatic measuring and control signals. They particularly serve as intermediate element to provide transition between electric measuring equipment and pneumatic controllers or between electric control equipment and pneumatic control valves.



The converters have a load-independent direct current input of 4 to 20 mA. The output is a pneumatic standardized signal of 0.2 to 1.0 bar (3 to 15 psi) at supply pressure 1.4 bar (20 psi) or 0.4 to 2 bar (6 to 30 psi) at supply pressure 2.4 bar. The converters are rack-mounting units in Eurocard C format and have a rack width of 7 HP (35 mm/ 1.38 inch).

Special features:

- Positive dynamic properties
- Small input resistance (approx. 300 Ω) and, hence, a small load impedance (approx. 6 V at 20 mA)
- Versions with converter module 6112 are available with reverse characteristic
- Pneumatic plug connectors seal the air lines when the converter is removed from the rack
- Front adjustable zero and span
- Electronic switch-off function

Versions

Model	6127-	<input type="checkbox"/>	<input type="checkbox"/>
Explosion protection			
Without		0	
Version			
Rack-mounting unit w. converter module 6109			1
Rack-mounting unit w. two converter modules 6109			2
Rack-mounting unit w. converter module 6112			3
Rack-mounting unit w. two converter modules 6112			4
Rack-mounting unit w. converter module 6109 and 6112, respectively			5

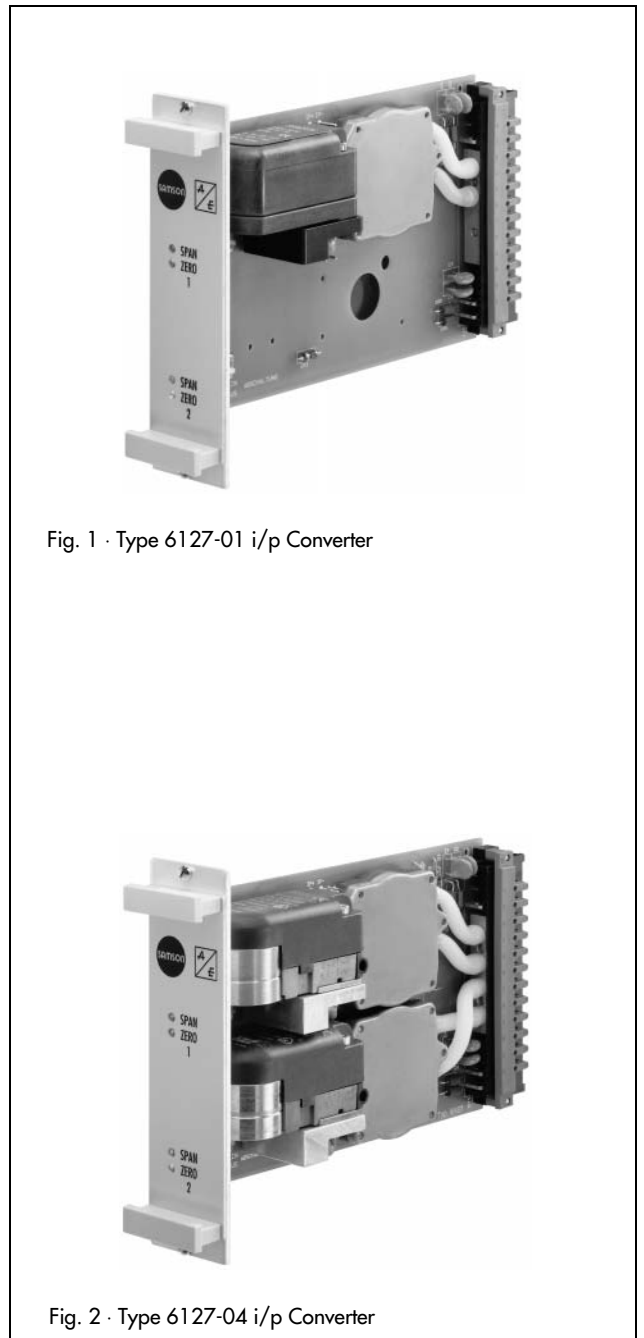

Fig. 1 · Type 6127-01 i/p Converter

Fig. 2 · Type 6127-04 i/p Converter

Principle of operation

Depending on the version, the converters have one or two i/p converter modules that work according to the force balance principle. The direct current i flows through the plunger coil (2) which is located in the field of a permanent magnet (3). The balance beam (1) is used to compare the force of the plunger coil, which is proportional to the current i , with the force of the back pressure which, in turn, is generated by the air jet. The air jet comes from the nozzle (7) and acts on the flapper plate (6). Compressed air is supplied to the volume amplifier (9) and passes through the restriction (8) and the nozzle (6) to finally hit against the flapper plate (7).

When the input current i increases, the force of the plunger coil also increases, causing the flapper plate (7) to approach the nozzle (6). As a result, the back pressure increases and along with it the cascade pressure p_K . The latter is rising until a new equilibrium is reached and p_K corresponds to the current i . The downstream volume amplifier (9) amplifies the air output capacity of the i/p converter module and produces the output pressure (p_A).

The lower range value (ZERO) and measuring span (SPAN) can be adjusted on the front plate.

Converters with an input signal of 4 to 20 mA are equipped with a slide switch (5) that activates or deactivates an electronic switch-off function. Whenever the input signal falls below $4.08 \text{ mA} \pm$ differential gap, the switch-off function causes the pneumatic output to be vented up to approximately 100 mbar (24.5 psi). Thus, the tight closing function of a control valve can be guaranteed.

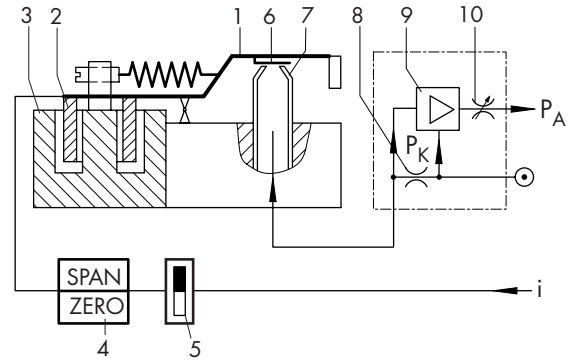

- 1 Balance beam
- 2 Plunger coil
- 3 Permanent magnet
- 4 Adjuster for zero and span
- 5 Slide switch for electronic switch-off function
- 6 Flapper plate
- 7 Nozzle
- 8 Restriction
- 9 Volume amplifier
- 10 Volume restriction

Fig. 3 · Functional diagram of Type 6127 i/p Converter

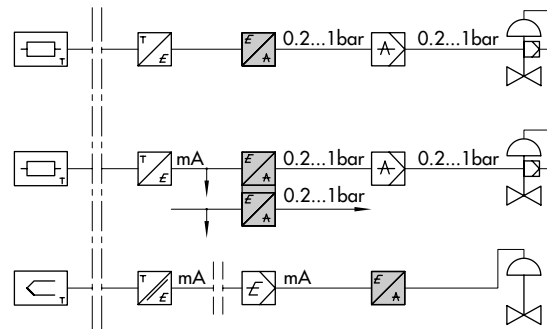

Fig. 4 · Application

Technical data

Type	6127-01, 6127-02, 6127-05	6127-03, 6127-04, 6127-05
Explosion protection	Without	
	Converter module 6109	Converter module 6112
Input	4 to 20 mA	
Load	Approx. 300 Ω at 6V (20 mA)	
Output	0.2 to 1 bar (3 to 15 psi)	0.2 to 1 bar (3 to 15 psi); 0.4 to 2 bar (6 to 30 psi);
Air output capacity ¹⁾	at Q _{max} at Q _{min.}	>1.3 m _n ³ /h - min. connected air volume: > 0.025 dm ³ >0.5 m _n ³ /h - min. connected air volume: > 0.006 dm ³
Supply air	1.4 ± 0.1 bar (20 ± 1.5 psi) or 2.4 ± 0.1 bar (36 ± 1.5 psi)	
Air consumption	Max. 0.150 m _n ³ /h per duct at 1.4 bar upstream pressure	
Performance ²⁾	Characteristic: output linear to input	
Hysteresis	≤ 0.3 % of the final value	
Deviation from terminal-based linearity	≤ 1 % of the final value	
Influence in % of the final value	Air supply: 0.3 %/0.1 bar (0.3%/1.45 psi)	
	Alternating load, failure of supply air, interruption of input current: ≤ 0.1 %	
	Ambient temperature: lower range value ≥ 0.02 %/K; measuring span ≤ 0.03 %/K	
Dynamic behavior		
Connected air volume	0.1 dm ³	
Limit frequency	8 Hz	
Phase shift	-128°	
Variable position	< 3.5 % when output < 1 bar (14.5 psi) < 1.5 % when output > 1 bar (14.5 psi)	
Environmental conditions, degree of protection, weights		
Permissible ambient temperature	-10 to +60 °C (+14 to 140°F)	
Permissible relative humidity	5 to 90 %	
Permissible storage temperature	-40 to +80 °C (-40 to 175°F)	
Degree of protection	IP 00	
Weights	approx.	Type 6127-01, -03: 0.25 kg (0.55lb) Type 6127-02, -04, -05: 0.35 kg (0.75lb)

¹⁾ Measured with 2 m (6.5 ft) hose 4x1 mm

²⁾ Complies with IEC 770

Electrical connections

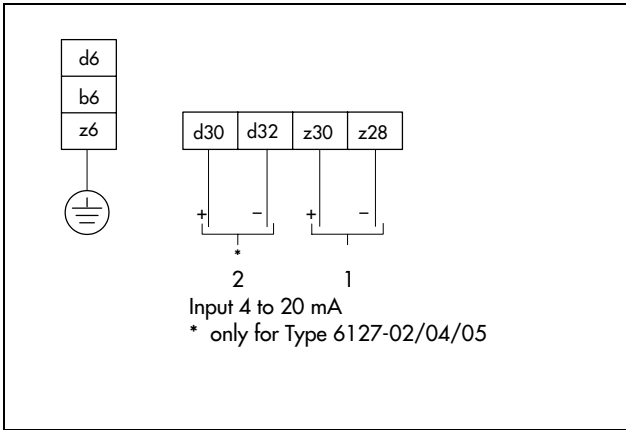

Dimensions in mm

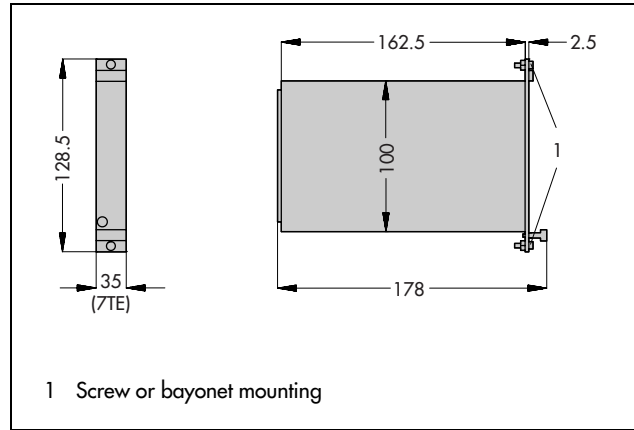

Pneumatic connections

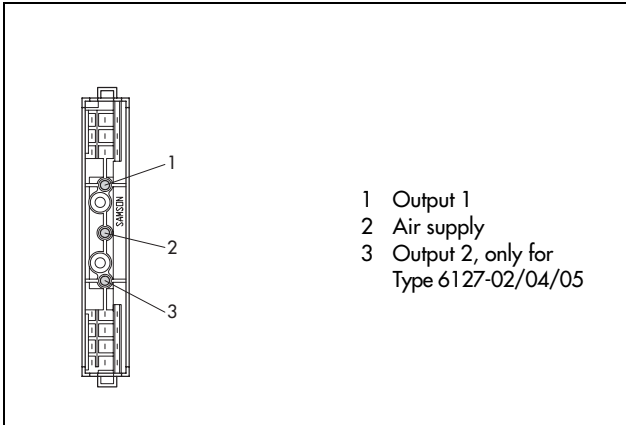

Connection

The rack-mounting units are delivered as ready-wired 19" racks according to DIN 41 494 Part 1 and 5. They are part of a pre-assembled automation unit.

The electric plug connectors comply with DIN 41 612 (Form F). The integrated pneumatic plug connectors seal the air lines when the converter module is removed from the rack.

Ordering text

Type 6127-.. i/p Converter

Input ... mA

Output ... bar/psi

Operating direction increasing-increasing, increasing-decreasing (only converter module 6112)

Screw or bayonet mounting

Accessories:

Electrical terminal block (Form F) for crimping/soldering connection



SAMSON CONTROLS INC.
 1 - 105 Riviera Drive
 Markham · Ontario · Canada · L3R 5J7
 Tel. (905) 474-0354 · Telefax (905) 474-0998
 Internet: <http://www.samsoncontrols.com>

SAMSON CONTROLS INC.
 4111 Cedar Boulevard
 Baytown · Texas · USA · 77520-8588
 Tel. (281) 383-3677 · Telefax (281) 383-3690
 Internet: <http://www.samson-usa.com>

T 6127

T 6127 CA