

Electropneumatic Converters for Pneumatic Signals

p/i Converter Type 6132

For four-wire connection

Application

Conversion of pneumatic signals into electric standardized signals, especially suitable as transfer element between pneumatic and electric measuring and control equipment.



p/i converters serve as interface between pneumatic and electric measuring and control units, being used for example to connect pneumatic transmitters to electric controllers, computers and process control systems.

The input variable is a pneumatic standardized signal and the output variable an electric dc or dc current signal.

The Type 6132 p/i converters are designed for four-wire connection.

They are available as rack-mounting units for 19" racks, as rail-mounting units for top hat rails, or finally as field devices.

Their special features are as follows:

- Compact version with a plug-in width of 4 HP (20 mm/ 0.78 inch) or with space-saving cases.
- Low hysteresis and good dynamic response due to pressure transducer operating on the capacity principle or with deposited strain gauge.
- Version with limit switch and/or test sockets on the front panel used to check the input and output signals.

Versions

Type	6132-	<input type="checkbox"/>	<input type="checkbox"/>
Explosion protection		0	
Case			1
Rack-mounting unit, single			4
Rail-mounting unit			

All rack-mounting units are optionally available with mounting types screw mounting or bayonet mounting.

Options

Type 6132-01 incl. limit switch

Type 6132-01 incl. test sockets to check the electric output signal and the pneumatic input signal



Fig. 1 · Type 6132-01 p/i converter, rack-mounting unit



Fig. 2 · Type 6132-04 p/i converter, rail-mounting unit

Principle of operation (Figs. 3 and 4)

The pressure transducer (1) is used to convert the pressure p of the pneumatic input signal into an electric dc voltage signal. Metal-film strain gauges are connected to form a measuring bridge which is supplied by a constant voltage source (2).

The dc voltage signal which is proportional to the pressure is amplified to a defined level in the measuring amplifier (3). Lower range value and span can be adjusted on the potentiometers located on the front panel.

The output stage (4) issues a load-independent dc signal or a dc voltage signal. The type of output signal and the range can be adjusted via jumpers, or for Type 6132-04 via switches.

The power transformer (5) and rectifier (6) provide the converter with energy and isolate it from the power supply. Converters with 24-V supply are isolated by means of a dc module. The latter is used instead of the rectifier (6) and the power transformer (5).

Rack-mounting units of the Type 6132-01 can be equipped with a limit switch (7) which issues a signal to the LED and the relay with floating double-throw contact (8) in case the adjusted limit value is exceeded or not reached. The operating mode of the LED (activated either when limit value is exceeded or not reached) and the relay (closed- or open-circuit switching) can be selected via plugs. The limit value is adjusted by a potentiometer connected to the test sockets in the front panel.

In addition, it is possible to equip the rack-mounting units with further test sockets for checking the pneumatic input signal and the electric output signal during operation. The pneumatic input signal is taken from a self-sealing test socket. To check the output signal, an interlock diode is connected in the output circuit. So you can connect an mA-meter having an internal resistance of $R_i \leq 10 \Omega$ for monitoring purposes. Whereas in case of voltage outputs, a resistance of $5 \text{ k}\Omega$ is connected between test socket and output terminal for protection against short circuits. In order to keep measuring errors at a minimum, only voltmeters with an internal resistance of $R_i \geq 5 \text{ M}\Omega$ should be connected.

Installation

Rack-mounting units are mainly supplied as ready-wired 19" racks according to DIN 41 494 Part 5. In this case, they are part of a factory-assembled automation package. Each rack is able to receive up to 21 rack-mounting units.

All case versions can be mounted in any position.

Ordering text

Type 6132-... p/i converter

Input: ... bar / ... psi

Rack-mounting units: screw- / bayonet mounting

Output: ... mA / ... V,

Power supply: 230 V AC / 115 V AC / 24 V AC / 24 V-

Type 6132-01: option of limit switch, pneumatic and electric test socket

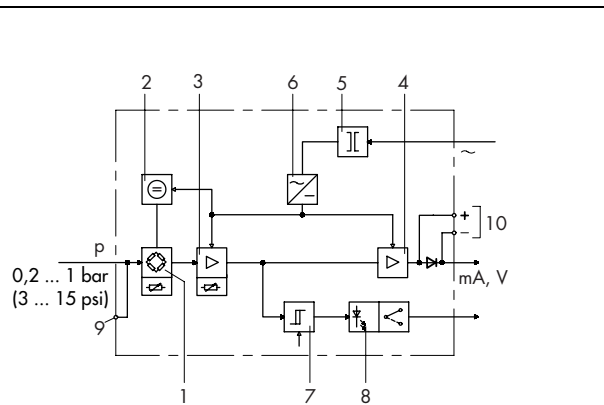
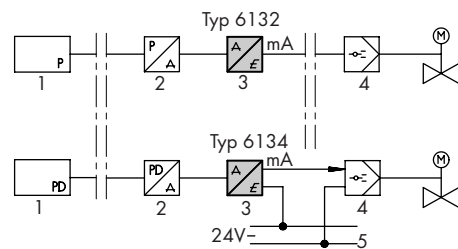

Fig. 3 · Functional diagram

- | | |
|---|---|
| p Pneumatic input signal | 4 Output stage |
| 1 Pressure transducer with strain gauge measuring bridge and potentiometer for adjustment of lower range value (ZERO) | 5 Power transformer |
| 2 Constant voltage source | 6 Rectifier |
| 3 Measuring amplifier and potentiometer for adjustment of span (SPAN) | 7 Limit switch (special version) |
| | 8 LED and floating double-throw contact (special version) |
| | 9 Test socket f. pneum. signal |
| | 10 Test socket f. output current |



- | | |
|-------------------------|-------------------|
| 1 Transducer | 3 p/i converter |
| 2 Pneumatic transmitter | 4 Controller |
| | 5 Two-wire system |

Fig. 4 · Example of application

Technical data acc. to VDE/VDI 2191 · All pressures in bar (psi) gauge

Type	6132-01	6132-04
	Rack-mounting unit	Rail-mounting unit
Input	0.2...1.0 bar (3...15 psi), overloadable to 2 bar (30 psi) or 0.4...2 bar (6...30 psi), overloadable to 4 bar (60 psi)	0.2 to 1 bar (3 to 15 psi), overloadable to 5 bar (70 psi); alternative ranges on request
Output	4...20 mA; 0...20 mA; 0...10 V or 2...10 V	4 ... 20 mA; 0 ... 20 mA; 0 ...5 V; 1...5 V; 0...10 V or 2...10 V
Permissible load for 0(4)...20 mA	≤ 650 Ω	≤750 Ω at 20 mA
for 0(2)...10 , 0(1)...5 V	≥ 2 kΩ	≥ 2 kΩ
Limit switch	Double-throw switching contact	-
Switching capacity	Max. 300 W	
Switching current	3 A; cos φ = 1	
Switching voltage	230 V~	
Power supply	230 V AC, 115 V AC, 24 V AC (+10/-15 %) 48...62 Hz, 24 V- (approx. 3.5 W) on request	24 VDC (18...36 V) 1.5 W 230 V AC, 115 V AC, 24 V AC (+10/-15 %), 50/60 Hz, 3 VA
Performance	Output linear to input	
Deviation from conformity	≤ 0.2 % ¹⁾	
Hysteresis	≤ 0.1 % ²⁾	≤ 0.05%
Range of inversion	≤ 0.03 % ¹⁾	
Ripple of output signal	≤ 0.5 % ¹⁾	
Temperature influence	≤ 0.2 %/10 K for zero and span ¹⁾	≤ 0.15 %/10 K for zero and span ¹⁾
Power supply influence	≤ 0.1 % upon changes in voltage within the given limits ¹⁾	-
Load influence	≤ 0.1 % ¹⁾ in the load range	-
EMC noise emission	EN 50081 Part 1	
EMC noise immunity	EN 50082 Part 2	
Device safety	EN 61010	
Class of protection	I	
Overvoltage category	II	
Degree of contamination	2	
Environmental conditions		
Degree of protection DIN 40 050	IP 00	IP 20
Ambient temperature	-20 °C...+65 °C (-4...+150°F)	-20 °C...+70 °C (-4...+160°F)
Storage temperature	-40 °C...+85 °C (-40...+185°F)	
Connections and assembly		
Air connection	Integrated pneumatic plug connector	Hose connection for hose 4 x 1, (external Ø 6 mm);
Electrical connection	Electric plug connector according to DIN 41 612 (Style F)	Terminals for lines 0.5 to 2.5 mm ² Unflexible lines 0.2...4 mm ² Flexible lines 0.2...2.5 mm ²
Assembly	Screw or bayonet mounting	Top hat rail, 35 mm wide, DIN EN 50 002 (mounting base for G rail, 32 mm wide, DIN EN 50 035, on request)
Weight approx.	0.35kg (0.75lb)	0.35kg (0.75lb)

¹⁾ Error indication refers to output span

Dimensions in mm

Rack-mounting units

- 1 Screw or bayonet mounting

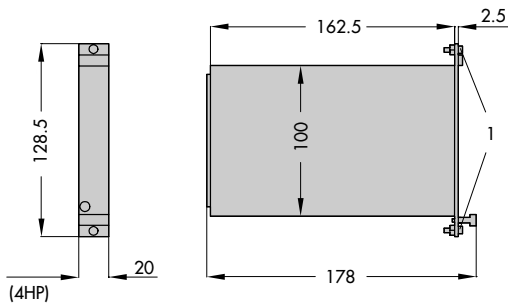

Rail-mounting units

- 1 Top hat rail
- 2 Air connection
- 3 Electrical connection

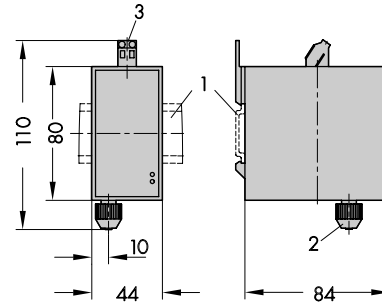

Electrical connection

Rack-mounting units

Test sockets at current output

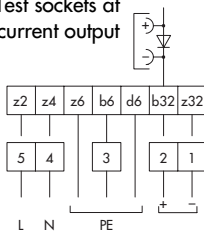

Power supply

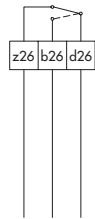

Output

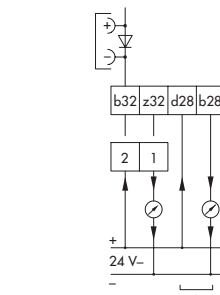

Floating double-throw contact

Rail-mounting units

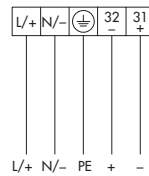

Power supply Output

Specifications subject to change without notice.



SAMSON CONTROLS INC.
1 - 105 Riviera Drive
Markham · Ontario · Canada · L3R 5J7
Tel. (905) 474-0354 · Telefax (905) 474-0998
Internet: <http://www.samsoncontrols.com>

SAMSON CONTROLS INC.
4111 Cedar Boulevard
Baytown · Texas · USA · 77520-8588
Tel. (281) 383-3677 · Telefax (281) 383-3690
Internet: <http://www.samson-usa.com>

T 6132

T 6132 CA