

Automation System TROVIS 6400

Process Control Stations TROVIS 6412 and 6442



Designed for panel mounting (dimensions of front frame:
72 x 144 mm (2.83 x 5.67 inches) or 19-inch rack mounting

Application

Microprocessor-controlled process control stations suitable not only for constructing simple control loops, but for solving complex control problems as well. Used in the automation of industrial and process engineering plants.



Function blocks which are permanently stored in memory allow the user to define pre-configured control systems and select various functions. Entries are made in CONFIGURATION and PARAMETER levels, resp.

Configuration and parameterization data are entered directly on the station via keys located on the front panel. Instead of local entry, this data can be entered on a PC via an optional program. Moreover, data can be transferred to and from the control stations via a specially designed COPA pen (COPA = CONfigure and PARameterize).

The process control stations can be equipped with a serial interface for use in a digital process control system.

Special features

Pre-configured control circuits:

- Fixed setpoint control for single or multi-component control
- Follow-up control, optionally with internal/external switch-over
- Synchronous control
- Ratio control with internal/external switch-over
- Cascade control (master and slave control)

Additional features include, among other functions:

- Filtering, square roots and function generalization of inputs
- Logical operations of input quantities (addition, subtraction, multiplication, averaging, comparison, ratio)
- Operation with dual reference variables (setpoints)
- Setpoint ramp and output-variable ramp
- Optionally linear or non-linear control algorithms, plus compensation algorithms
- Control signal limits (fixed, variable or by an input quantity)
- Split-range operation
- Definition of start-up and re-start criteria, alarm messages when pre-determined limits are exceeded
- Tuning of control parameters or control of process parameters via an external signal
- Limiting control

Versions

TROVIS

Panel-mounting unit

Rack-mounting (plug-in) unit

64□2

1

4



Fig. 1 · TROVIS 6412 Process Control Station
(unit designed for mounting in panels)



Fig. 2 · TROVIS 6442 Process Control Station
(unit designed for mounting in racks)

Inputs and outputs (Fig. 3)

The process control stations are available with four different input cards offering either three or four analog inputs. Universal input options include: Standardized current mA or voltage V signals; potentiometers; Pt 100 temperature sensors; thermocouples; transmitter supply (see table "Technical data"). In addition, each station contains three binary inputs.

A jack of the integrated serial interface (Figs. 4, 12) is located on the front panel, to which either a COPA pen or a special COPA adapter (to a PC) can be attached.

In addition, an RS-485 serial interface can optionally be integrated in the process control stations.

Standard outputs include: One continuous control output; one two-point/three-point output; one binary output for fault messages.

The functional range of the process control stations can optionally be enhanced with any of the following: One additional continuous control output; one analog output; two limit (alarm) relays.

Operating the process control stations (Fig. 4)

The process control stations operate according to a clear, three-level operating structure: 1) **OPERATING level**, 2) **PARAMETER level** and 3) **CONFIGURATION level**.

Besides the three operating levels above, additional levels are available which support the following series of functions: Display all input and output variables as absolute values; tune control parameters; configure the RS-485 serial interface; display analog input variables in standardized form; display firmware numbers of the process control station and the serial interface; select passcodes for the PARAMETER and CONFIGURATION levels, resp.; reset to default values (factory configuration); level for checking the entire display field.

All levels can be directly accessed on the station via the assigned keys (1 to 8), each of which can be inhibited.

OPERATING level

This is the standard operating level of the process control station. All values relating to the reference variable (setpoint) and the controlled variable (actual value) are digitally displayed in the LCD (Liquid Crystal Display) (10). The deviation (i.e., error) and the controlled variable are represented as bar graphs. Additional functions of the OPERATING level include, for example: Modify the value of the reference variable; manually operate the connected control valve; open the cascade (i.e., with cascade control).

PARAMETER level

This level is used to numerically define all process parameters (control parameters, transit times, constants) that are specified in the configuration. They can be viewed in the LCD field.

This level can also be protected against unauthorized access by means of a personal passcode (key number) or via the software.

CONFIGURATION level

This level sets up the process control station for the required control task. For this purpose, a maximum of 59 configuration blocks must be selected and configured. The configuration blocks selected determine the parameters, these of which can be defined in the PARAMETER level above.

The CONFIGURATION level can be protected by three means: i.e., a code number; a remote signal; via the software.

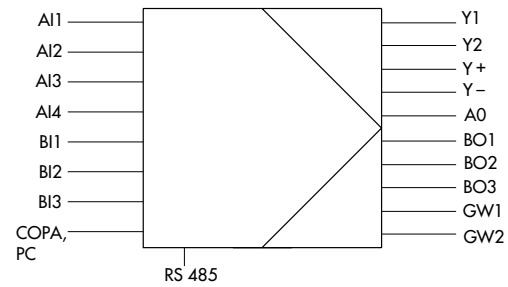

AI	Analog input	Y	Control output
BI	Binary input	AO	Analog output
COPA	Pen (COnfigure and PArameterize)	BO	Binary output
PC	Personal computer	GW	Limit (alarm) relay

Fig. 3 · Equipping and signal assignment

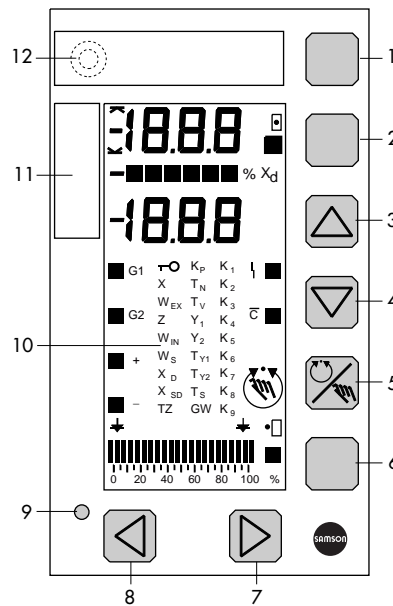

- | | | | |
|---|---|----|--|
| 1 | Display and execute key for all levels | 7 | Key for increasing the value of the output variable |
| 2 | Switch-over key W _{EX} /W _{IN} or open/close the cascade control | 8 | Key for reducing the value of the output variable |
| 3 | Cursor key for increasing values (reference variable*, parameter values, configuration blocks) | 9 | Display of measuring range exceeding, faults |
| 4 | Cursor key for reducing values | 10 | Liquid Crystal Display (LCD) field with displays for the reference and controlled variable***; parameters; bar diagrams for deviation (i.e., error) and the output variable; various input/output displays |
| 5 | Manual/automatic mode selector | 11 | Exchangeable label |
| 6 | Reset key for switching to the OPERATING level, reference variable display or override of the controller start-up following power failure | 12 | Jack for COPA pen or PC |
- * Setpoint
** Manipulated variable
*** Actual value

Fig. 4 · Panel and operator controls

Technical data

Universal inputs		Input card 1	Input card 2	Input card 3	Input card 4						
Input 1		mA, V input, potentiometer transmitter supply	Pt 100 temperature sensor in 2/3 or 4-wire circuit		Thermocouple with internal or external reference junction						
Input 2		mA, V input, transmitter supply		Pt 100 temperature sensor in 2/3 or 4-wire circuit	mA, V input, transmitter supply						
Input 3		mA or V input	mA, V input, transmitter supply	Omitted	Omitted						
Input 4		mA, V input or potentiometer		mA, V, potentiometer, transmitter supply	mA, V input or potentiometer						
mA or V input	Measuring ranges	4(0) to 20 mA or 2(0) to 10 V; 0.2(0) to 1 V; 1(0) to 5 V									
	Measuring range switch-over	Soldering jumpers									
	Maximum permissible values	Current ± 50 mA, voltage ± 25 V									
	Internal resistance	Current $R_i = 50 \Omega$; voltage $R_i = 200 \text{ k}\Omega$									
	Permissible d.c. voltage	0 to 10 V									
	Error	Zero point $< 0.2 \%$, span $< 0.2 \%$, linearity $< 0.2 \%$									
	Temperature influence	Zero point $< 0.1 \%/10 \text{ K}$; span $< 0.1 \%/10 \text{ K}$									
Pt 100 temperature sensor	Measuring ranges ¹⁾	<table border="0"> <tr> <td>-50 to 100 °C</td> <td>-68 to 212 °F</td> </tr> <tr> <td>0 to 200 °C</td> <td>+32 to 392 °F</td> </tr> <tr> <td>100 to 600 °C</td> <td>212 to 1112 °F</td> </tr> </table>				-50 to 100 °C	-68 to 212 °F	0 to 200 °C	+32 to 392 °F	100 to 600 °C	212 to 1112 °F
	-50 to 100 °C	-68 to 212 °F									
	0 to 200 °C	+32 to 392 °F									
	100 to 600 °C	212 to 1112 °F									
	Measuring range switch-over	Soldering jumpers and configuration									
Line resistances	Two wires $R_{L1} + R_{L2} < 10 \Omega$, three wires $R_{L1} = R_{L2} = R_{L3} < 50 \Omega$, four wires, each $R_L < 100 \Omega$										
Error	Zero point $< 0.2 \%$, gain $< 0.2 \%$, linearity $< 0.2 \%$										
Temperature influence	Zero point $< 0.2 \%/10 \text{ K}$; span $< 0.2 \%/10 \text{ K}$										
Potentiometer	Measuring range	0 to 1 k Ω , $\pm 100 \Omega$, three wires									
	Line resistances	$R_L < 10 \Omega$ each									
	Error	Zero point $< 0.2 \%$, gain $< 0.2 \%$									
	Temperature influence	Zero point $< 0.1 \%/10 \text{ K}$; gain $< 0.2 \%/10 \text{ K}$									
Thermocouple	Specifications on request										
Transmitter supply	16 to 23 V, maximum 50 mA, short-term short-circuit protection										
Binary inputs	3 binary inputs, switching contact (load 36 V DC, approximately 3 mA) or external switching voltage (24 V DC, $\pm 30 \%$, maximum 6 mA), selection via soldering jumpers										
Standard outputs											
Continuous control output	Signal range	4(0) to 20(22) mA, permissible load $< 750 \Omega$ or 2(0) to 10 V, permissible load $> 3 \text{ k}\Omega$									
	Output range	-10 to 110 %									
	Error	Zero point $< 0.3 \%$, nominal final value $< 0.3 \%$, linearity $< 0.3 \%$									
	Temperature influence	Zero point $< 0.1 \%/10 \text{ K}$; nominal final value $< 0.1 \%/10 \text{ K}$									
Switching output	1 two-point or three-point output, 250 V AC (1 A AC, $\cos \varphi = 1$)										
Binary output (BO 3)	Electrically isolated transistor output, $U_{\min} = 3 \text{ V DC}$, $U_{\max} = 42 \text{ V DC}$, $I_{\max} = 30 \text{ mA DC}$										
Options	Continuous control output	1 second continuous control output for split-range operation; signal range, output range, Error and temperature influence same as first continuous control output (see above)									
	Analog output	4(0) to 20 mA, permissible load $< 750 \Omega$ or 2(0) to 10 V or -10 to 10 V, permissible load $> 3 \text{ k}\Omega$ Error and temperature influence same as first continuous control output (see above)									
	Limit relay	2 relays, floating contacts, maximum 250 V AC (1 A AC, $\cos \varphi = 1$) or maximum 250 V DC (0.1 A DC)									
	Binary outputs	2; floating contacts; maximum 42 V AC (0.1 A AC); 42 V DC (0.05 A DC)									

Interfaces		
Serial interface on the front panel		RS-232 in conjunction with COPA adapter
	Data communications protocol	SAMSON Protocol 6482
	Number of subscribers	1
	Length of cable	< 2 m (< 6.56 ft)
	Transmittable data	CONFIGURATION, PARAMETER
COPA pen		Read/write pen for transmitting of the CONFIGURATION or PARAMETER data to/from the process control station via the front-panel serial interface
Serial interface RS-485 (optional)	Data communications protocol	Modbus RTU 584
	Data transmission	Asynchronous, half duplex, 4 wires or 2 wires
	Character format	RTU (8 bits), 1 start bit, 8 data bits, 1(2) stop bit(s), optional parity bit
	Baud rate	300 to 19,200 bits/s
	Number of addressable stations	246
	Number of subscribers	32 (can be extended with repeater)
	Length of cable	< 1200 m (< 3900 ft); with repeater, maximum 4800 m (15750 ft)
	Transmittable data	CONFIGURATION, PARAMETER, operating state, process variables, fault messages
General specifications		
Displays	Read-off angle	Readable on all sides, high-contrast and lighted Liquid Crystal Display (LCD)
	Displays	3½-digit reference variable (setpoint) display and 3½-digit controlled variable display; bar graph displays for deviation (i.e., error) and output variable; LED displays for range exceeding, alarm message when limits are exceeded, manual operation, faults, etc.; parameter display (only in the PARAMETER level)
Configuration		Permanently stored function blocks for fixed setpoint control, follow-up control with or without internal/external switch-over, cascade control, synchronous control, ratio control, SPC control, limiting control, DDC backup fixed setpoint control via binary contact
Power supply		230 V AC (200 to 250 V AC), 120 V AC (102 to 132 V AC), 24 V AC (21.5 to 26.5 V AC), Optional 24 V DC (19 to 34 V DC); 48 to 62 Hz
Power consumption		Approximately 18 VA
Temperature range		0 to 50°C (32 to 120°F) operation, -20 to 70 °C (-4 to 160°F) shipping and storage
Degree of protection		Panel-mounting unit: Front IP 54, case IP 30, terminals IP 00; rack-mounting unit: IP 00
Overvoltage category		II
Degree of contamination		2
Conformance to European standards		EN 61 010, edition March 1994
Electrical connection	Functional earthing	Panel-mounting unit: On case with Cu flexible lead > 2.5 mm ² ; Rack-mounting unit: Connector type F (DIN 41 612), Cu flexible lead > 2.5 mm ²
	Power voltage and process signals	Panel-mounting unit: Screw terminals 1.5 mm ² ; Rack-mounting unit: Two-part connectors type F (DIN 41 612), soldering or crimp types
Total delay time ²⁾		Approximately 100 ms
Resolution		Input and output, approximately 11 bits
Dimensions		See Figs. 6 to 8
Weight		Panel-mounting unit, approximately 1.9 kg (4.2lb); rack-mounting unit, approximately 1 kg (2.2lb)

¹⁾ Specific measuring ranges on request

²⁾ Depending on how many functions are configured

Front-panel serial interface (Fig. 5)

This serial interface enables the user to configure and parameterize the process control station via a special COPA adapter or COPA pen, where COPA is the abbreviation for COnfigure and PArameterize.

When a PC is connected to the process control station, the user is able to enter configuration and parameter data via the menu-driven software program TROVIS 6482, which is a user-friendly MS-windows application. In addition to entering configuration and parameter data, this program also contains functions for documenting the station.

The COPA pen can be used to upload or download data applicable to the PARAMETER or CONFIGURATION levels. This data is stored in the COPA pen until it is overwritten. In this way, the data contents of the process control station can very easily be duplicated and archived directly on the premises.

Communication with a higher-order control station

The serial interface, which can be optionally integrated, meets the RS-485 hardware requirements (RS = Recommended Standard) according to EIA (Electronic Industries Association).

The process data can be transmitted up to a distance of 1200 meters. If a broader coverage is required, repeaters have to be connected between segments. How many depends on the number of stations connected and the length of the cable.

Coupling the process control station to a control station requires that an RS-485/RS-232 interface converter be connected.

The TROVIS 6412 or TROVIS 6442 Process Control Stations communicate with the control station according to the master/slave principle, based on the Modbus RTU protocol. All of the stations coupled on the bus are cyclically interrogated and send their reply to the master control station directly following a request.

"Monitoring and operator control" with the primary control station provides the user with maximum transparency and reliable process control, this of which is backed by user-configurable process graphics software:

- Display of process data (digital, analog)
- Trend characteristics
- Display of operating and fault messages
- Process visualization through free vector graphics
- Filing of process data for later retrieval

Because of the standardized data format, the process data can be processed afterwards on a microcomputer or notebook using off-the-shelf data base and spreadsheet programs.

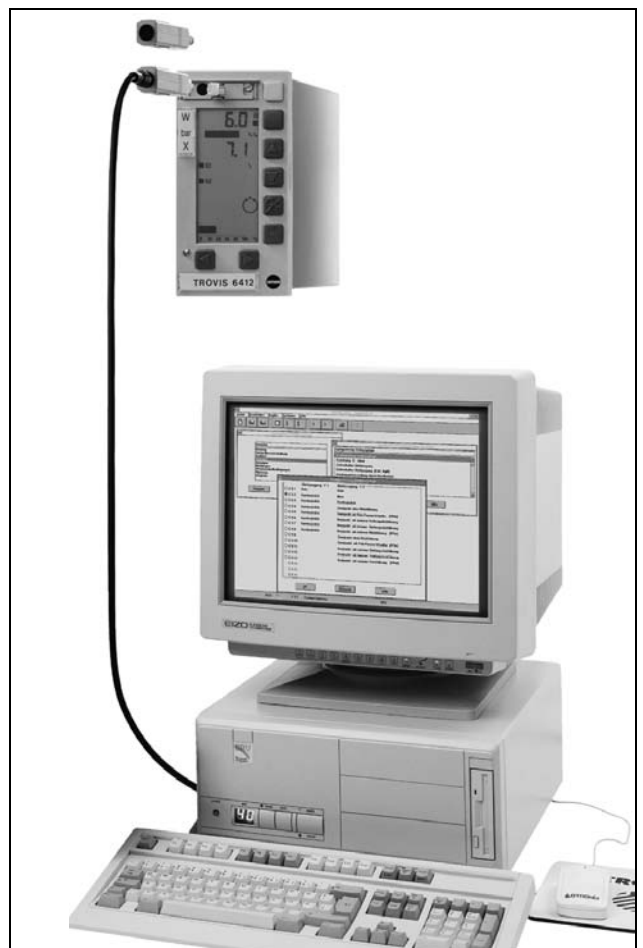
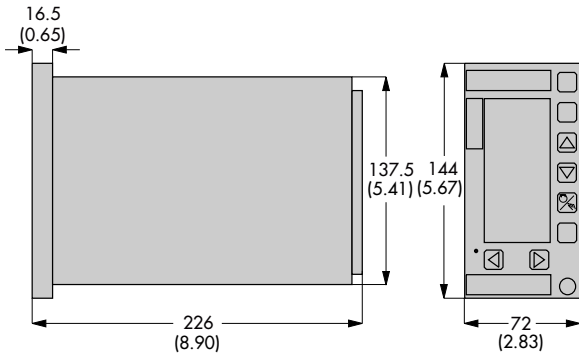

Fig. 5 · Communication via the front-panel serial interface

Dimensions in mm (inch)



Panel cut-out $68^{+0.7} \times 138^{+1.0}$ ($2.68^{+0.02} \times 5.43^{+0.04}$)

Fig. 6 · TROVIS 6412 Process Control Station (panel-mounting unit)

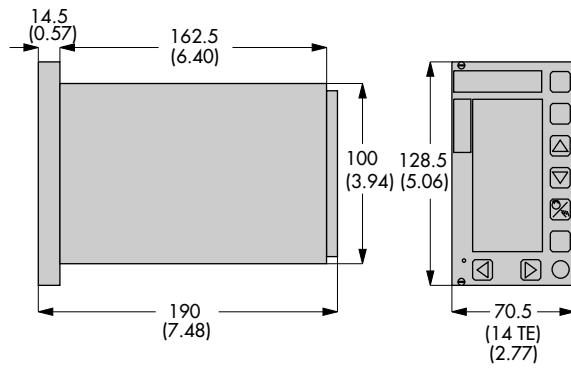

TE = HP (Horizontal Pitch)

Fig. 7 · TROVIS 6442 Process Control Station (rack-mounting unit)

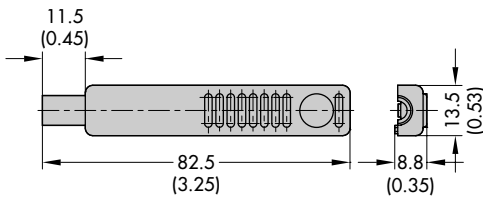

Fig. 8 · COPA pen

Installation

TROVIS 6412 panel-mounting unit

With two standard attaching components C according to DIN 43 835 for mounting in a control panel

TROVIS 6442 rack-mounting unit for 19-inch racks

Ordering text

Process Control Station TROVIS 6412/6442

Input card/2/3/4

Power supply 230/120/24 V

With/without RS-485 serial interface

COPA pen

Software program TROVIS 6482 to enter configuration and parameter data, including COPA adapter (to a PC)



SAMSON CONTROLS INC.
1 - 105 Riviera Drive
Markham · Ontario · Canada · L3R 5J7
Tel. (905) 474-0354 · Telefax (905) 474-0998
Internet: <http://www.samsoncontrols.com>

SAMSON CONTROLS INC.
4111 Cedar Boulevard
Baytown · Texas · USA · 77520-8588
Tel. (281) 383-3677 · Telefax (281) 383-3690
Internet: <http://www.samson-usa.com>

T 6412

T 6412 CA