

Pneumatic Control Valves Type 3251/3271 and Type 3251/3277

Application

Control valve for process engineering applications with high industrial requirements.

Nominal sizes ½" to 8" (15 to 200 mm)

Pressure ratings ANSI Class 150 to 2500

Temperatures -328 to +932 °F (-200 to +500 °C)

These valves comply with ANSI, ASME and ASTM standards

The control valves consist of a body with trim, bonnet, yoke and a pneumatic actuator, with optional metal bellows or insulating extension. The valves may be also equipped with electric, electrohydraulic, or hand-operated actuators, as well as control accessories and other instrumentation.

Features

- Modular design, rugged and heavy duty construction, full range of body and trim materials
- Field retrofitable metal bellows seals and extension bonnets
- Self-adjusting, live-loaded PTFE/Carbon V-ring stuffing box
- Excellent dynamic response and high trim stability
- V-port asymmetric port-guided plugs (above Cv 5)
- Self-locking seats, exchangeable for various Cv values
- Low profile, reversible, multi-spring/rolling diaphragm actuator
- NAMUR (IEC 534-6) accessory mounting standard
- Complete selection of actuator options, positioners and control accessories

Standard Versions

- **Body materials** · ASTM Cast A 216 WCB, A 217 WC6, A 351 CF8M
- **End connections** · Raised-Face Flanges
- **Packing** · PTFE/Carbon V-ring spring-loaded/self-adjusting, temperature range: 15 to 430 °F (-10 to 220 °C)
- **Trim** · Equal percentage characteristic, metal-to-metal seal

Options

- **Body Materials** · A 217 WC9, A 352 LCB, A 351 CF8, Hastelloy C, Monel, and others
- **Packing** · Adjustable, high-temperature (HT) packing for temperatures from 15 to 660 °F (-10 to 350 °C) and others
- **Extension Bonnet** · For extreme temperatures from -328 to 932 °F (-200 to 500 °C)
- **Metal bellows seal** · For complete seal between process and atmosphere, with test connection and backup PTFE packing
- **Characteristic** · Linear (quick-opening on request)
- **Trim materials** · Stellite, Hastelloy C, Monel, Tungsten Carbide, ceramic and others
- **Plug seal** · PTFE soft seal or lapped-in metal seal
- **Pressure balanced version** · For high differential pressures
- **Class 1500 and 2500** · On request
- **End connections** · RTJ, socketweld and buttweld ends
- **Flow divider** · For noise level reduction, see Data Sheet T 8081
- **Heating jacket, micro trim, versions for sour gas according to NACE** · Details on request



Fig. 1 · Type 3251/3271 Pneumatic Globe Control Valve

Actuator Combinations

Type 3251/3271 (Fig. 1) · With Type 3271 Pneumatic Actuator · For operation with or without yoke-mounted positioner, details see T 8310

Type 3251/3277 · With Type 3277 Pneumatic Actuator · For integral positioner/accessory mounting according to SAMSON "Valve Management" System, details see T 8311

DIN Versions · See Data Sheet T 8015 EN **JIS** · On request

Fail-safe action

Depending on the arrangement of the diaphragm plate and springs within the actuator, the control valve offers two different fail-safe actions upon loss of air supply (see Technical Data Sheets T 8310 and T 8311 for details):

Actuator "extends" stem (fail-close)

The actuator springs close the valve upon loss of air supply.

Actuator "retracts" stem (fail-open)

The actuator springs open the valve upon loss of air supply.

Notes on the differential pressure tables 4a to 6d

The differential pressure tables listed have been prepared under the following conditions:

- Process medium flow directed against the closing direction of the valve plug (flow-to-open valve)
- Version with PTFE/Carbon V-ring stuffing box
- With the maximum differential pressures specified, the leakage rates specified in Table 1 are not exceeded.
- The differential pressure specified can be limited by the Pressure-Temperature Diagram.

For versions with soft-sealing or lapped-in plugs, metal bellows seal, balanced plug with graphite seal ring or $p_2 \leq 0$ psi (0 bar), consult SAMSON.

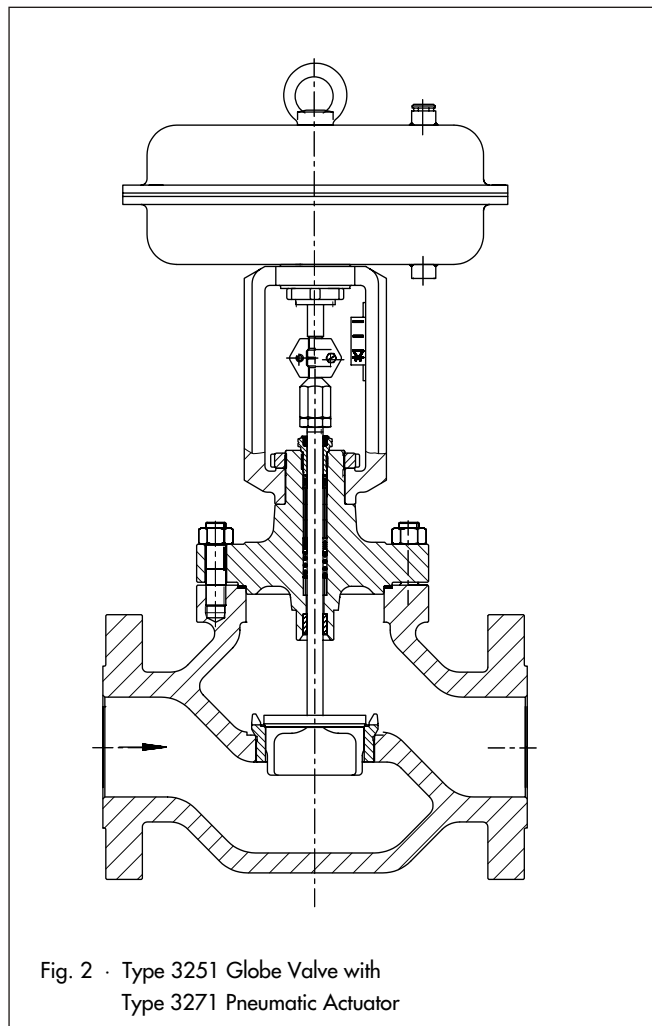

Fig. 2 · Type 3251 Globe Valve with
Type 3271 Pneumatic Actuator

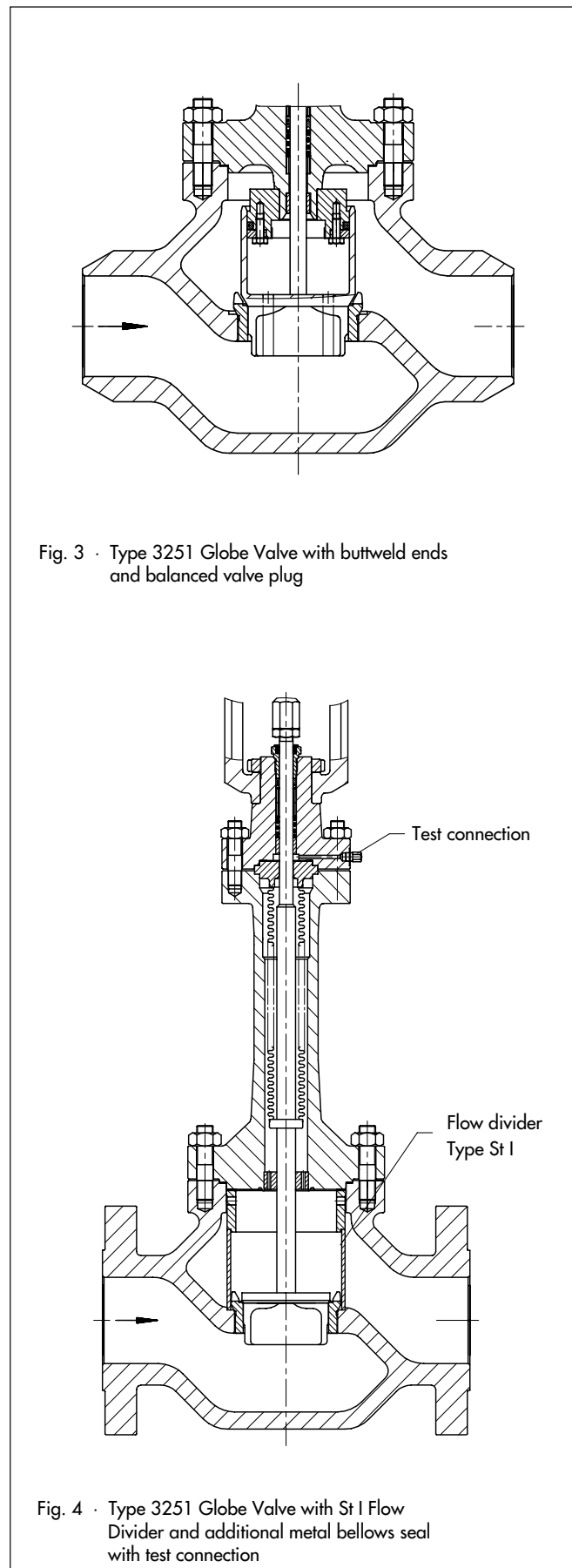

Fig. 3 · Type 3251 Globe Valve with butt-welded ends
and balanced valve plug

Fig. 4 · Type 3251 Globe Valve with St I Flow
Divider and additional metal bellows seal
with test connection

Table 1 · Technical Data

Nominal Valve Size		½" ... 6" · 8" in Class 600				
Body material, ASTM (also see Table 2)		Carbon steel A 216 WCB	High-Temperature Carbon steel A 217 WC6	High-Temperature Carbon steel A 217 WC9	Low-Temperature Carbon steel A 352 LCB	Stainless steel A 351 CF8M
End connections	Flanges	RF (raised face) and RTJ (ring-type joint)				
	Welding ends	Socketweld, buttweld, according to ANSI B16.11, B16.25				
Pressure Rating	Class	150 ... 900, according to ANSI B16.34 ¹⁾				
Seat/Plug seal		Metal sealing, soft sealing or lapped-in metal sealing				
Packing Design		V-ring, spring-loaded, self-adjusting or adjustable				
Flow Direction (standard)		Flow to Open (FTO)				
Seat bore diameter, rated travel, Cv/Kvs		See Table 3				
Characteristic		Equal percentage, linear or quick-opening				
Terms for valve sizing according to ISA-75.02 and IEC 60 534, parts 2-1 and 2-2		$F_L=0.95$, $X_T=0.75$ (at 75% rated travel)				
Rangeability		50:1				
Dimensions and Weights		See Tables 7...10				
Temperature ranges in °F (°C) · Max. operating pressures according to Pressure-Temperature Diagrams (see Information Sheet T 8000-2)						
Body without insulating section		15 ... 430 °F (–10 ... 220 °C) · Up to 660 °F (350 °C) with high-temperature packing				
Body with	Insulating or bellows section	–20...800 °F (–29...427 °C)	–20...930 °F (–29...500 °C)	–51...650 °F (–46...343 °C)	–58...800 °F (–50...427 °C)	
Valve plug ²⁾	Standard	Metal sealing	–325...930 °F (–196...500 °C)			
		Soft sealing	–325...430 °F (–196...220 °C)			
	Balanced	PTFE ring	–325...430 °F (–196...220 °C)			
		Graphite ring	430...930 °F (220...500 °C)			
Leakage rate class according to ANSI/FCI F70-2 (IEC 60 534 Part 4)						
Valve plug	Standard	Metal sealing	IV			
		Soft sealing	VI			
		Lapped-in metal	IV-S2 · 4" and upwards: IV-S1			
	Balanced	Metal sealing	With PTFE balancing seal: IV · With graphite balancing seal: III			

¹⁾ Up to Class 2500 on request.

²⁾ Only in combination with a suitable body material.

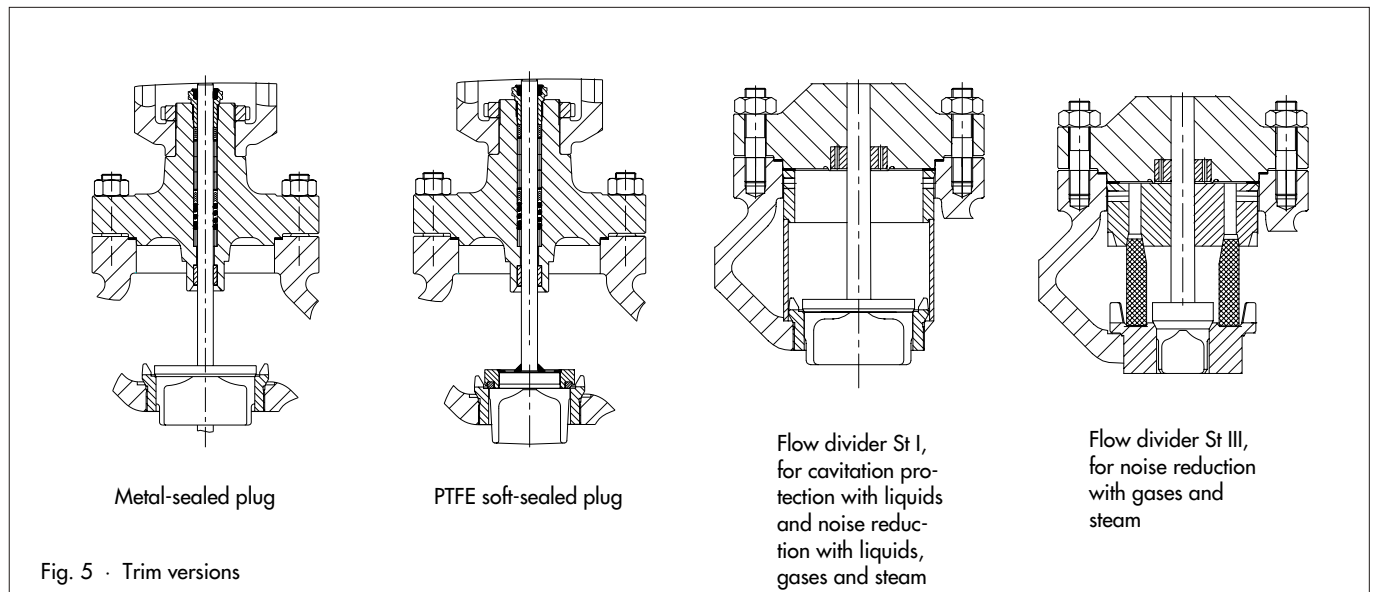

Fig. 6 · Type 3251 Globe Valve components

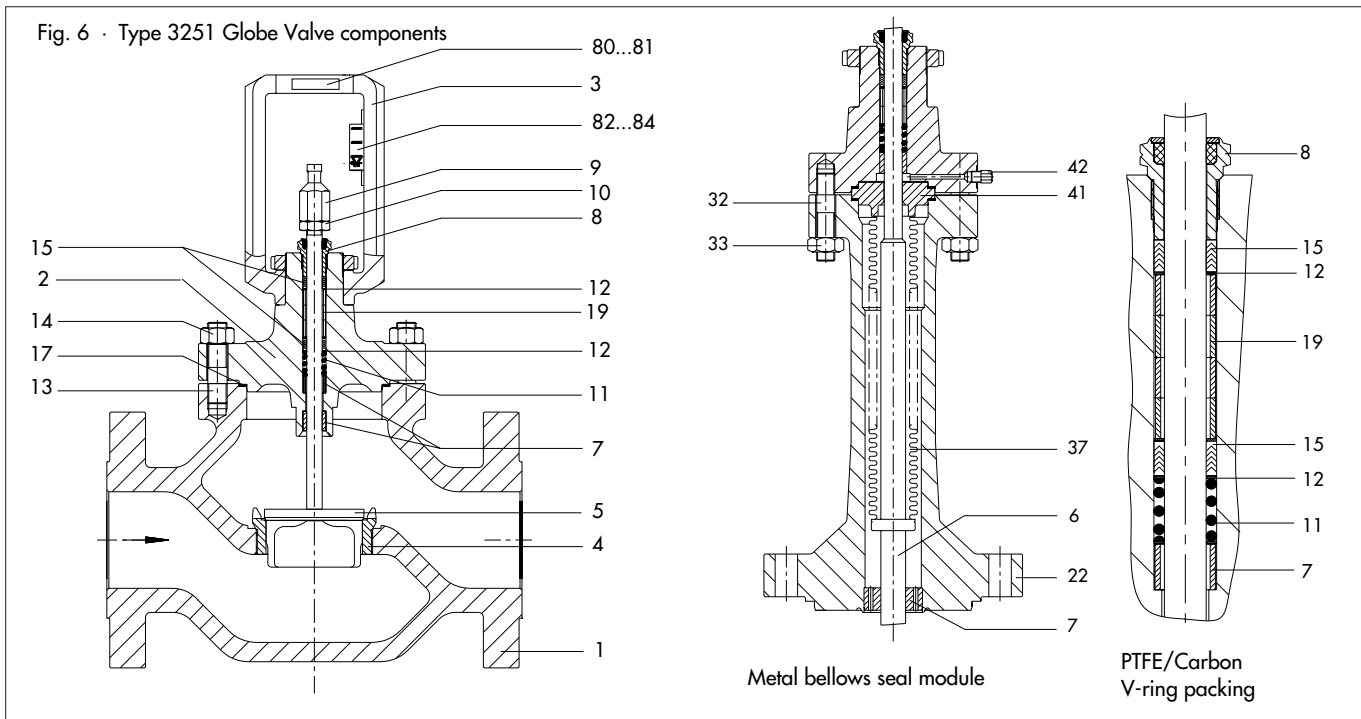

Table 2 · Materials (WN = Material Number according to DIN)

Item	Description	ASTM/AISI Material Description			
		Carbon Steel Cast A 216 WCB	High-Temperature Carbon Steel Cast A 217 WC6 Cast A 217 WC9	Low-Temperature Carbon Steel Cast A 352 LCB	Stainless Steel Cast A 351 CF8M
2	Bonnet	A 182 F12		A 350 LF2	A 182 F316
3	Yoke	A 395 (WN 0.7043)			
4	Seat ¹⁾	AISI 410 (WN 1.4006)		AISI 316Ti (WN 1.4571)	
5	Plug ^{1), 2)}	AISI 410 (WN 1.4006)		AISI 316Ti (WN 1.4571)	
6	Plug stem	AISI 410 (WN 1.4006)		AISI 316Ti (WN 1.4571)	
7	Guide bushing	AISI 440B (WN 1.4112)			Hastelloy C
8	Packing nut	AISI 316Ti (WN 1.4571) with carbon insert (guide)			
9	Coupling nut	AISI 430F (WN 1.4104)			
10	Counter nut	AISI 430F (WN 1.4104)			
11	Packing spring	AISI 301 (WN 1.4310)			
12	Packing washer	AISI 316Ti (WN 1.4571)			
13	Body stud	A193 B7			A193 B8M Cl.2
14	Hex nut	A194-2H	A194-7	A194-2H	A194-8M
15	V-ring packing	PTFE with carbon (others on request)			
17	Gasket	AISI 316Ti (WN 1.4571)			
19	Packing bushing	AISI 316Ti (WN 1.4571)			
22	Extension	A 182 F12		A 350 LF2	A 182 F316
32	Hex bolt	A193 B7			A193 B8M Cl.2
33	Hex nut	A194-2H	A194-7	A194-2H	A194-8M
37	Bellows insert	AISI 316Ti (WN 1.4571)			
41	Bellows retaining nut	AISI 316Ti (WN 1.4571)			
42	Test connection nut	AISI 316Ti (WN 1.4571)			
80...84	Label, indicator, bracket, screw, nameplate, rivets	AISI 304 (WN 1.4301)			

¹⁾ Seats and metal-sealing plugs also available with Stellite facing or complete Stellite 6 plug (Seat bore ≤ 48 mm). Other materials (Monel, Hastelloy C, Tungsten Carbide) also available

²⁾ Soft-sealed plug version, with PTFE-glass fiber composite. Pressure balanced and versions with flow divider, materials on request.

Table 3 · C_v and K_{vs} values

Table 3a · Overview

C_v	0.12	0.2	0.3	0.5	0.75	1.2	2	3	5	7.5	12	20	30	47	75	120	190	290	420	735	
C_v I	–						1.7	2.6	4.2	7	10.5	17	26	42	67	105	170	265	375	650	
C_v III	–								3.5	5.6	9	14	23	35	55	90	140	220	315	–	
Seat ID, ∅ in	0.24						0.47			0.95			1.22	1.5	1.97	2.48	3.15	3.94	4.92	5.91	7.87
Travel in	0.6"												1.2"			2.4"					
K_{vs}	0.1	0.16	0.25	0.4	0.63	1.0	1.6	2.5	4.0	6.3	10	16	25	40	63	100	160	250	360	630	
K_{vs} I	–						1.45	2.2	3.6	5.7	9	14.5	22	36	57	90	144	225	320	560	
K_{vs} III	–								3	4.8	7.5	12	20	30	47	75	120	190	270	–	
Seat ID, ∅ mm	6						12			24			31	38	50	63	80	100	125	150	200
Travel mm	15												30			60					

Table 3b · Standard versions (without flow divider) · Versions in shaded fields also available with balanced valve plugs

C_v	0.12	0.2	0.3	0.5	0.75	1.2	2	3	5	7.5	12	20	30	47	75	120	190	290	420	735
K_{vs}	0.1	0.16	0.25	0.4	0.63	1.0	1.6	2.5	4.0	6.3	10	16	25	40	63	100	160	250	360	630
Size in mm																				
1/2"	15	•	•	•	•	•	•	•	•	•										
1"	25	•	•	•	•	•	•	•	•	•										
1 1/2"	40	•	•	•	•	•	•	•	•	•	•	•	•							
2"	50								•	•	•	•	•	•						
3"	80								•	•	•	•	•	•	•	•	•			
4"	100												•	•	•	•	•	•		
6"	150														•	•	•	•	•	•
8"	200																•	•	•	•

Table 3c · Versions with St I flow divider (C_v I/K_{vs} I) · Versions in shaded fields also available with balanced valve plugs

C_v I	–						1.7	2.6	4.2	7	10.5	17	26	42	67	105	170	265	375	650
K_{vs} I	–						1.45	2.2	3.6	5.7	9	14.5	22	36	57	90	144	225	320	560
Size in mm																				
1/2"	15						•	•	•											
1"	25						•	•	•	•	•									
1 1/2"	40						•	•	•	•	•	•	•							
2"	50								•	•	•	•	•	•						
3"	80								•	•	•	•	•	•	•	•	•			
4"	100												•	•	•	•	•	•		
6"	150														•	•	•	•	•	•
8"	200																•	•	•	•

Table 3d · Versions with St III Flow Divider (C_v III/K_{vs} III) · Versions in shaded fields also available with balanced valve plugs

C_v III	–								3.5	5.6	9	14	23	35	55	90	140	220	315	–
K_{vs} III	–								3	4.8	7.5	12	20	30	47	75	120	190	270	–
Size in mm																				
2"	50								•	•	•									
3"	80								•	•	•	•	•	•						
4"	100												•	•	•	•	•	•		
6"	150														•	•	•	•	•	•
8"	200																•	•	•	•

Table 4 · Differential pressure tables · Unbalanced valve plugs

Values specified in the shadowed columns correspond to the standard application, i.e. rated travel · Differential pressures specified in the white columns apply to maximum pre-tensioned springs. Differential pressures enclosed in parentheses refer to mid-travel position. Observe the notes on the differential pressure tables, listed on page 2.

Table 4a · Permissible differential pressures Δp for valves with metal sealing and without metal bellows · Pressures in psi

For actuators employing fail-safe action: Actuator “extends” stem · Valves closed at supply pressure 0 psi

Bench range (psi) for actuators with effective area of (in ² /cm ²)		54/350		6...18		6...30		12...36		9...45		18...52		20...34		30...48		–		–		
		108/700		3...15		6...18 (12...18)		6...30		12...36 (24...36)		9...45		18...52 (36...52)		20...34 (27...34)		30...48 (39...48)		35...55 (45...55)		38...62 (50...62)
217/1400										7...36		15...45 (30...45)		16...36		20...39 (30...39)		19...41		25...46 (36...46)		
434/2800		6...18		12...36		15...45		18...52		13...23		16...26		15...30		18...34		16...38		22...45		
2x434/2x2800		(12...18)		(24...36)		(30...45)		(36...52)				(19...24)				(22...30)				(27...38)		
Required supply pressure (psi)						Final spring value + 3 psi																
Nominal size		C _v	K _{vs}	Actuator		Δp with p ₂ = 0 psi																
in	mm			in ²	cm ²																	
1/2" to 1 1/2"	15 to 40	0.12 to 1.2	0.1 to 1.0	54	350	668	1479	1479	3088	2291	4712	5510	5800	–	–							
		2 to 3	1.6 to 2.5	54	350	668	1479	1479	3088	2291	4712	5510	5800	–	–							
		5 to 12	4 to 10	54	350	126	325	325	732	530	1137	1338	2044	–	–							
2"	50			108	700	–	(1537)	–	(3146)	–	(4770)	(3654)	(5365)	(5800)	–	–						
				54	350	117	319	319	723	520	1126	1329	2030	–	–							
1 1/2" to 3"	40 to 80			108	700	–	(1522)	–	(3146)	–	(4756)	(3654)	(5365)	(5800)	–	–						
				54	350	62	184	184	426	304	654	789	1212	–	–							
1 1/2" to 4"	40 to 100			108	700	–	(909)	–	(1870)	–	(2842)	(2175)	(3204)	(3625)	(4118)	–	–					
				54	350	–	117	117	278	197	439	519	801	–	–							
2" to 4"	50 to 100			108	700	62	155	155	342	248	527	620	947	1063	1178	–	–					
				217	1400	–	(713)	–	(1450)	–	(1827)	–	(1870)	–	(2247)	–	–					
3" to 6"	80 to 150			108	700	–	91	91	209	151	326	384	590	662	736	–	–					
				217	1400	–	(443)	–	(912)	–	(1147)	–	(1176)	–	(1411)	–	–					
3" to 6"	80 to 150			108	700	–	–	–	126	90	198	236	362	409	454	–	–					
				217	1400	–	(272)	–	(562)	–	(707)	–	(726)	–	(871)	–	–					
4" to 6"	100 to 150			108	700	–	–	–	78	–	126	149	230	259	288	–	–					
				217	1400	–	(172)	–	(358)	–	(451)	–	(462)	–	(555)	–	–					
8"	200			108	700	–	–	–	78	–	124	148	229	258	287	–	–					
				217	1400	–	(171)	–	(356)	–	(449)	–	(461)	–	(554)	–	–					
6"	150			217	1400	–	–	–	108	64	137	152	197	183	242	–	–					
				434	2800	(227)	(465)	(584)	(703)	–	(361)	–	(451)	–	(539)	–	–					
8"	200			217	1400	–	–	–	107	62	137	152	197	181	240	–	–					
				434	2800	(226)	(464)	(584)	(703)	–	(361)	–	(449)	–	(539)	–	–					
				2x434	2x2800	(452)	(928)	(1168)	(1406)	–	(722)	–	(899)	–	(1079)	–	–					
6"	150			217	1400	–	–	–	74	–	94	104	136	126	166	–	–					
				434	2800	(156)	(322)	(404)	(487)	–	(249)	–	(312)	–	(374)	–	–					
8"	200			217	1400	–	–	–	74	–	94	104	135	125	166	–	–					
				434	2800	(155)	(322)	(404)	(487)	–	(249)	–	(312)	–	(372)	–	–					
				2x434	2x2800	(310)	(644)	(809)	(974)	–	(499)	–	(623)	–	(745)	–	–					
8"	200			217	1400	–	–	–	–	–	58	75	68	93	–	–						
				434	2800	(87)	(180)	(226)	(272)	–	(139)	–	(174)	–	(209)	–	–					
				2x434	2x2800	(174)	(359)	(452)	(545)	–	(278)	–	(348)	–	(417)	–	–					

Table 4b · Permissible differential pressures Δp for valves with metal sealing and without metal bellows · Pressures in bar

For actuators employing fail-safe action: Actuator "extends" stem · Valves closed at supply pressure 0 bar

Bench range (bar) for actuators with effective area of (in ² /cm ²)		54/350		0.4...1.2		0.4...1.2		0.8...2.4		0.6...3.0		1.2...3.6		1.4...2.3		2.1...3.3		–		–			
		108/700		0.2...1.0		0.4...1.2 (0.8...1.2)		0.4...2.0		0.8...2.4 (1.6...2.4)		1.2...3.6 (2.4...3.6)		1.4...2.3 (1.85...2.3)		2.1...3.3 (2.7...3.3)		2.35...3.8 (3.05...3.8)		2.6...4.3 (3.45...4.3)			
		217/1400										0.5...2.5		1.0...3.0 (2.0...3.0)		1.1...2.4		1.4...2.7 (2.05...2.7)		1.3...2.8		1.7...3.2 (2.45...3.2)	
		434/2800		0.4...1.2 (0.8...1.2)		0.8...2.4 (1.6...2.4)		1.0...3.0 (2.0...3.0)		1.2...3.6 (2.4...3.6)		0.9...1.6		1.1...1.8 (1.25...1.6)		1.0...2.1		1.25...2.35 (1.55...2.1)		1.1...2.6		1.5...3.0 (1.85...2.6)	
Required supply pressure (bar)						Final spring value + 0.2 bar																	
Nominal size		C _v	Kvs	Actuator		Δp with p ₂ = 0 bar																	
in	mm			in ²	cm ²																		
1/2" to 1 1/2"	15 to 40	0.12 to 1.2	0.1 to 1.0	54	350	46.1	102	102	213	158	325	380	400	–	–								
		2 to 3	1.6 to 2.5	54	350	46.1	102	102	213	158	325	380	400	–	–								
		5 to 12	4 to 10	54	350	8.7	22.4	22.4	50.5	36.6	78.4	92.3	141	–	–								
2"	50			108	700	–	(106)	–	(217)	–	(329)	(252)	(370)	(400)	–	–							
				54	350	8.1	22	22	49.9	35.9	77.7	91.7	140	–	–								
1 1/2" to 3"	40 to 80	20	16	108	700	–	(62.7)	–	(129)	–	(196)	(150)	(221)	(250)	(284)								
				54	350	4.3	12.7	12.7	29.4	21	45.1	54.4	83.6	–	–								
1 1/2" to 4"	40 to 100	30	25	108	700	–	(41.4)	–	(85.8)	–	(130)	(99.7)	(147)	(166)	(188)								
				54	350	–	8.1	8.1	19.2	13.6	30.3	35.8	55.3	–	–								
2" to 4"	50 to 100	47	40	108	700	4.3	10.7	10.7	23.6	17.1	36.4	42.8	65.3	73.3	81.3								
				217	1400	–	(49.2)	–	(100)	–	(126)	–	(129)	–	(155)								
3" to 6"	80 to 150	75	63	108	700	–	6.3	6.3	14.4	10.4	22.5	26.5	40.7	45.7	50.8								
				217	1400	–	(30.6)	–	(62.9)	–	(79.1)	–	(81.1)	–	(97.3)								
3" to 6"	80 to 150	120	100	108	700	–	–	–	8.7	6.2	13.7	16.3	25	28.2	31.3								
				217	1400	–	(18.8)	–	(38.8)	–	(48.8)	–	(50.1)	–	(60.1)								
4" to 6"	100 to 150	190	160	108	700	–	–	–	5.4	–	8.7	10.3	15.9	17.9	19.9								
				217	1400	–	(11.9)	–	(24.7)	–	(31.1)	–	(31.9)	–	(38.3)								
8"	200	190	160	108	700	–	–	–	5.4	–	8.6	10.2	15.8	17.8	19.8								
				217	1400	–	(11.8)	–	(24.6)	–	(31)	–	(31.8)	–	(38.2)								
6"	150	290	250	217	1400	–	–	–	7.5	4.4	9.5	10.5	13.6	12.6	16.7								
				434	2800	(15.7)	(32.1)	(40.3)	(48.5)	–	(24.9)	–	(31.1)	–	(37.2)								
8"	200	290	250	217	1400	–	–	–	7.4	4.3	9.5	10.5	13.6	12.5	16.6								
				434	2800	(15.6)	(32)	(40.3)	(48.5)	–	(24.9)	–	(31)	–	(37.2)								
				2x434	2x2800	(31.2)	(64)	(80.6)	(97)	–	(49.8)	–	(62)	–	(74.4)								
6"	150	420	360	217	1400	–	–	–	5.1	–	6.5	7.2	9.4	8.7	11.5								
				434	2800	(10.8)	(22.2)	(27.9)	(33.6)	–	(17.2)	–	(21.5)	–	(25.8)								
8"	200	420	360	217	1400	–	–	–	5.1	–	6.5	7.2	9.3	8.6	11.5								
				434	2800	(10.7)	(22.2)	(27.9)	(33.6)	–	(17.2)	–	(21.5)	–	(25.7)								
				2x434	2x2800	(21.4)	(44.4)	(55.8)	(67.2)	–	(34.4)	–	43	–	(51.4)								
8"	200	735	630	217	1400	–	–	–	–	–	4	5.2	4.7	6.4									
				434	2800	(6)	(12.4)	(15.6)	(18.8)	–	(9.6)	–	(12)	–	(14.4)								
				2x434	2x2800	(12)	(24.8)	(31.2)	(37.6)	–	(19.2)	–	(24)	–	(28.8)								

Table 5 · Permissible differential pressures Δp for valves with unbalanced plug with metal sealing and without metal bellows seal

For actuators employing fail-safe action: Actuator "retracts" stem · Valves open at supply pressure 0 bar

Bench range in psi/bar for actuators with effective area (in ² /cm ²):						Table 5a · Pressures in psi				Table 5b · Pressures in bar			
						3 ... 15 (3 ... 9)				0.2 ... 1.0 (0.2 ... 0.6)			
54 / 350													
108 / 700													
217 / 1400													
434 / 2800													
2x434 / 2x2800													
Required supply pressure (psi/bar)						20	36	60	90	1.4	2.4	4.0	6.0
Nominal size		C _v	K _{vs}	Actuator		Δp with p ₂ = 0 psi				Δp with p ₂ = 0 bar			
in	mm			in ²	cm ²								
½" to 1½"	15 to 40	0.12 to 1.2	0.1 to 1.0	54	350	1479	5510	5800	–	102	380	400	–
		2 to 3	1.6 to 2.5	54	350	1464	5510	5800	–	101	380	400	–
		5 to 12	4 to 10	54	350	325	1335	2943	4973	22.4	92.1	203	343
2"	50	108 to 700	108 to 700	54	350	313	1324	2943	4959	21.6	91.3	203	342
				108	700	(1522)	(3538)	(5800)	–	(105)	(244)	(400)	–
1½" to 3"	40 to 80	20	16	54	350	180	786	1754	2958	12.4	54.2	121	204
				108	700	(906)	(2117)	(4060)	5800	(62.5)	(146)	(280)	(400)
1½" to 4"	40 to 100	30	25	54	350	114	517	1161	1972	7.9	35.7	80.1	136
				108	700	(594)	(1407)	(2682)	4307	(41)	(97)	(185)	(297)
2" to 4"	50 to 100	47	40	108	700	153	619	1364	2291	10.6	42.7	94.1	158
				217	1400	(710)	(1638)	(3132)	4988	(49)	(113)	(216)	(344)
3" to 6"	80 to 150	75	63	108	700	90	383	851	1438	6.2	26.4	58.7	99.2
				217	1400	(441)	(1029)	(1957)	3132	(30.4)	(71)	(135)	(216)
3" to 6"	80 to 150	120	100	108	700	–	235	525	889	–	16.2	36.2	61.3
				217	1400	(271)	(633)	(1218)	(1943)	(18.7)	(43.7)	(84)	(134)
4" to 6"	100 to 150	190	160	108	700	–	148	333	567	–	10.2	23	39.1
				217	1400	(171)	(403)	(775)	(1232)	(11.8)	(27.8)	(53.5)	(85)
8"	200	190	160	108	700	–	145	332	564	–	10.0	22.9	38.9
				217	1400	(168)	(401)	(773)	(1232)	(11.6)	(27.7)	(53.3)	(85)
6"	150	290	250	217	1400	–	197	435	733	–	13.6	30	50.6
				434	2800	(226)	(525)	(1000)	1595	(15.6)	(36.2)	(69)	(110)
8"	200	290	250	217	1400	–	195	433	731	–	13.5	29.9	50.4
				434	2800	(224)	(523)	(1000)	1595	(15.5)	(36.1)	(69)	(110)
				2x434	2x2800	(449)	(1044)	(2001)	3190	(31)	(72)	(138)	(220)
6"	150	420	360	217	1400	–	136	301	507	–	9.4	20.8	35
				434	2800	(156)	(362)	(693)	1108	(10.8)	(25)	(47.8)	(76.4)
8"	200	420	360	217	1400	–	135	300	506	–	9.3	20.7	34.9
				434	2800	(156)	(362)	(693)	1106	(10.7)	(25)	(47.8)	(76.3)
				2x434	2x2800	(310)	(725)	(1386)	2204	(21.4)	(50)	(95.6)	(152)
8"	200	735	630	217	1400	–	74	166	282	–	5.1	11.5	19.5
				434	2800	(85)	(201)	(388)	(620)	(5.9)	(13.9)	(26.8)	(42.8)
				2x434	2x2800	(171)	(403)	(777)	1241	(11.8)	(27.8)	(53.6)	(85.6)

Table 6 · Differential pressure tables · Balanced valve plugs with PTFE balancing seal (without bellows)

Values specified in the shadowed columns correspond to the standard application, i.e. to rated travel · Differential pressures specified in the white columns apply to maximum pre-tensioned springs.

Fail-safe action: Actuator “extends” stem · Valve closed at supply pressure 0 psi (0 bar)

Fail-safe action: Actuator “retracts” stem · Valve closed at required supply pressure

Tables 6a and 6b · Permissible differential pressures Δp · Pressures in psi

Table 6a Actuator “extends” stem											Table 6b Stem “retracts”			
Nominal bench range (psi) with actuator (in ² /cm ²)		108/700		6...30	12...36 (24...36)		7...36	15...45 (30...45)		9...45	18...52	6 ... 30 (6 ... 18)		
		217/1400			-			9...45	18...52					
		434/2800			-			9...45	18...52					
		2x434/2x2800			-			9...45	18...52					
Required supply pressure				psi		Final spring value + 3 psi					36	60	90	
Nominal size		C _v	K _{vs}	Actuator		Δp with p ₂ = 0 psi								
in	mm			in ²	cm ²									
3"	80	75	63	108	700	832	2247	-	-	1537	3654	832	5800	-
4"	100			217	1400	-	(5800)	-	(5800)	-	-	(5800)	-	-
6"	150	75	63	108	700	322	900	-	-	612	1479	322	2639	5539
				217	1400	-	(4379)	-	(5524)	-	-	(3204)	(5800)	-
3"	80	120	100	108	700	697	2117	-	-	1403	3524	697	5800	-
				4"	100	217	1400	-	(5800)	-	(5800)	-	-	(5800)
6"	150	120	100	108	700	267	845	-	-	557	1425	267	2581	5481
				217	1400	-	(4321)	-	(5481)	-	-	(3161)	(5800)	-
4"	100	190	160	108	700	539	1957	-	-	1245	3364	539	5800	-
				217	1400	-	(5800)	-	(5800)	-	-	(5800)	-	-
6"	150	190	160	108	700	201	780	-	-	491	1360	201	2523	5408
				217	1400	-	(4248)	-	(5408)	-	-	(3088)	(5800)	-
8"	200	190	160	108	700	66	293	-	-	179	519	66	971	2102
				217	1400	-	(1653)	-	(2102)	-	-	(1197)	(3001)	(5263)
6"	150	290	250	217	1400	700	1856	989	2436	-	-	700	5336	5800
				434	2800	-	(5800)	-	(5800)	-	(5800)	(5800)	-	-
				217	1400	261	713	374	939	-	-	261	2073	4335
8"	200	290	250	434	2800	-	(3422)	-	(4321)	-	(5234)	(2523)	(5800)	-
				2x434	2x2800	-	(5800)	-	(5800)	-	(5800)	(5046)	(5800)	-
				217	1400	617	1783	907	2349	-	-	619	5249	5800
6"	150	420	360	434	2800	-	(5800)	-	(5800)	-	(5800)	(5800)	-	-
				217	1400	229	681	342	907	-	-	221	1580	3842
				434	2800	-	(3393)	-	(4292)	-	(5205)	(2494)	(5800)	-
8"	200	420	360	2x434	2x2800	-	(5800)	-	(5800)	-	(5800)	(4988)	(5800)	-
				217	1400	165	617	278	844	-	-	165	1972	4234
				434	2800	-	(3335)	-	(4234)	-	(5133)	(2421)	(5800)	-
8"	200	735	630	2x434	2x2800	-	(5800)	-	(5800)	-	(5800)	(4843)	(5800)	-

Tables 6c and 6d · Permissible differential pressures Δp · Pressures in bar

Table 6c Actuator "extends" stem										Table 6d Stem "retracts"							
Bench range (bar) with actuator (in ² /cm ²)		108/700		0.4...2.0	0.8...2.4 (1.6...2.4)	-		-		0.6...3.0	1.2...3.6	0.4 ... 2.0 (0.4 ... 1.2)					
		217/1400				-		-		-	-						
		434/2800				0.5...2.5		1.0...3.0 (2.0...3.0)		0.6...3.0	1.2...3.6 (2.4...3.6)						
		2x434/2x2800															
Required supply pressure					bar					Final spring value + 0.2 bar					2.4	4.0	6.0
Size		C _v	K _{vs}	Actuator		Δp with p ₂ = 0 bar											
in	mm			in ²	cm ²												
3"	80	75	63	108	700	57.4	155	-	-	106	252	57.4	400	-			
	4"			100	217	1400	-	(400)	-	(400)	-	-	(400)	-	-		
6"	150	75	63	108	700	22.2	62.1	-	-	42.2	102	22.2	182	382			
				217	1400	-	(302)	-	(381)	-	-	(221)	(400)	-			
3"	80	120	100	108	700	48.1	146	-	-	96.8	243	48.1	400	-			
	4"			100	217	1400	-	(400)	-	(400)	-	-	(400)	-	-		
6"	150	120	100	108	700	18.4	58.3	-	-	38.4	98.3	18.4	178	378			
				217	1400	-	(298)	-	(378)	-	-	(218)	(400)	-			
4"	100	190	160	108	700	37.2	135	-	-	85.9	232	37.2	400	-			
				217	1400	-	(400)	-	(400)	-	-	(400)	-	-			
6"	150	190	160	108	700	13.9	53.8	-	-	33.9	93.8	13.9	174	373			
				217	1400	-	(293)	-	(373)	-	-	(213)	(400)	-			
8"	200	190	160	108	700	4.6	20.2	-	-	12.4	35.8	4.6	67	145			
				217	1400	-	(114)	-	(145)	-	-	(82.6)	(207)	(363)			
6"	150	290	250	217	1400	48.3	128	68.2	168	-	-	48.3	368	400			
				434	2800	-	(400)	-	(400)	-	(400)	(400)	-	-			
8"	200	290	250	217	1400	18	49.2	25.8	64.8	-	-	18	143	299			
				434	2800	-	(236)	-	(298)	-	(361)	(174)	(400)	-			
				2x434	2x2800	-	(400)	-	(400)	-	(400)	(348)	(400)	-			
6"	150	420	360	217	1400	42.6	123	62.6	162	-	-	42.7	362	400			
				434	2800	-	(400)	-	(400)	-	(400)	(400)	-	-			
8"	200	420	360	217	1400	15.8	47	23.6	62.6	-	-	15.3	109	265			
				434	2800	-	(234)	-	(296)	-	(359)	(172)	(400)	-			
				2x434	2x2800	-	(400)	-	(400)	-	(400)	(344)	(400)	-			
8"	200	735	630	217	1400	11.4	42.6	19.2	58.2	-	-	11.4	136	292			
				434	2800	-	(230)	-	(292)	-	(354)	(167)	(400)	-			
				2x434	2x2800	-	(400)	-	(400)	-	(400)	(334)	(400)	-			

Table 7a · Dimensions of standard version in inches

Globe Valve	Size	in	½"	1"	1½"	2"	3"	4"	6"	8"	
Length L	Class 150	in	7.25	7.25	8.75	10.00	11.75	13.88	17.75	21.38	
	Class 300	in	7.50	7.75	9.25	10.50	12.50	14.50	18.62	22.38	
	Class 600	in	8.00	8.25	9.88	11.25	13.25	15.50	20.00	24.00	
	Class 900	in	8.50	10.00	12.00	14.50	15.00	18.00	24.00	29.00	
H1 for actuator	350 cm ²	Class 150/600	in	15.43	15.43	15.91	17.99	18.19	18.97	-	
		Class 900	in	16.77	16.77	17.12	19.33	18.19	18.97	-	
	700 cm ²	Class 150/600	in	15.43	15.43	15.91	17.99	18.19	18.97	28.82	31.69
		Class 900	in	16.77	16.77	17.12	19.33	18.19	18.97	28.82	31.69
	1400 cm ²	Class 150/600	in	-			20.16	20.35	21.14	28.82	31.69
		Class 900	in	-			21.49	20.35	21.14	28.82	31.69
2800 cm ²	Class 150/900	in	-					28.42	32.16	35.04	
H2	Class 150	in	1.97	2.36	3.15	3.54	3.93	6.29	8.66	9.84	
	Class 300/600	in	2.36	2.75	3.54	3.93	4.72	7.08	9.25	10.63	
	Class 900	in	2.75	3.15	3.93	4.33	4.72	7.08	9.25	10.63	

Pneumatic Actuator	Size	350	700	1400	2800	2 x 2800
	in ²	54	108	217	434	2 x 434
Diaphragm Ø D	in	11.0	15.4	20.9	30.3	
H ¹⁾	in	3.23	7.71	11.3	24.4	44.5
H3 ²⁾	in	4.33	7.48	24.0	25.5	
Thread		M 30 x 1.5		M 60 x 1.5	M 100 x 2	
a (with Type 3271 Actuator)		NPT ⅜		NPT ¼	NPT 1	
a2 (with Type 3277 Actuator)		NPT ⅜			-	

1) Actuator 350 cm² without lifting ring

2) Minimum clearance for actuator disassembly

Table 7b · Weights of standard version in lbs

Globe Valve	Size	in	½"	1"	1½"	2"	3"	4"	6"	8"
Weight, without actuator	Class 150/300	lbs	34.2	38.6	47.4	83.8	130	172	443	941
	Class 600	lbs	49	62	80	141	225	302	750	1191
	Class 900	lbs	77	90	132	214	265	353	838	1433

Pneumatic Actuator	Size	350	700	1400	2800	2 x 2800	
	in ²	54	108	217	434	2 x 434	
Weight, Type 3271	Without	lbs	17.6	48.5	154.5	992	2095
	With handwheel	lbs	28.7	59.5	Only with side-mounted handwheel, see T 8310		
Weight, Type 3277	Without	lbs	26.5	57.6	-		
	With handwheel	lbs	37.5	68.5	-		

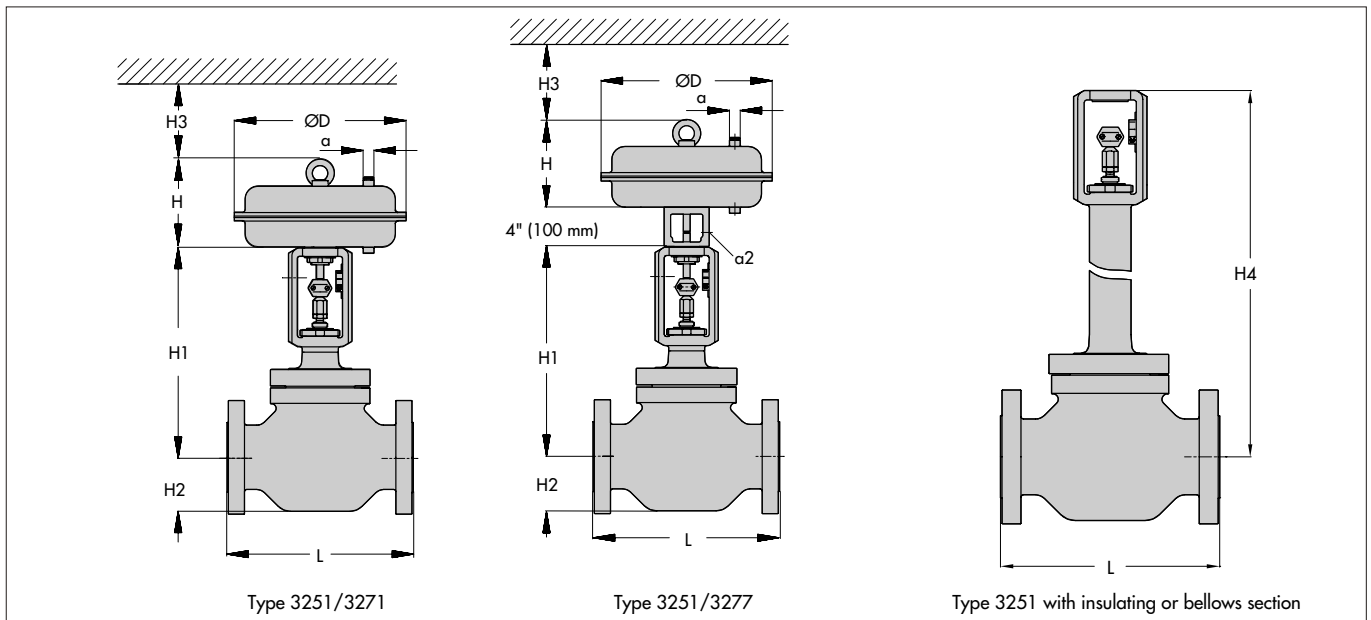

Table 8a · Dimensions of standard version in mm

Globe Valve	Size	in	½"	1"	1½"	2"	3"	4"	6"	8"	
		mm	15	25	40	50	80	100	150	200	
Length L	Class 150	mm	184	184	222	254	298	352	451	543	
	Class 300	mm	191	197	235	267	318	368	473	568	
	Class 600	mm	203	210	251	286	337	394	508	609	
	Class 900	mm	216	254	305	368	381	457	609	737	
H1 for actuator	350 cm ²	Class 150/600	mm	392	392	404	457	462	482	-	
		Class 900	mm	426	426	435	491	462	482		
	700 cm ²	Class 150/600	mm	392	392	404	457	462	482	732	805
		Class 900	mm	426	426	435	491	462	482	732	805
	1400 cm ²	Class 150/600	mm	-			512	517	537	732	805
		Class 900	mm	-			546	517	537	732	805
2800 cm ²	Class 150/900	mm	-			-		722	817	890	
H2	Class 150	mm	50	60	80	90	100	160	220	250	
	Class 300/600	mm	60	70	90	100	120	180	235	270	
	Class 900	mm	70	80	100	110	120	180	235	270	

Pneumatic Actuator	Size	350	700	1400	2800	2 x 2800
	cm ²	350	700	1400	2800	
Diaphragm Ø D	mm	280	390	530	770	
H ¹⁾	mm	82	196	287	620	1130
H3 ²⁾	mm	110	190	610	648	
Thread		M 30 x 1.5		M 60 x 1.5	M 100 x 2	
a (with Type 3271 Actuator)		NPT ¾		NPT ¾	NPT 1	
a2 (with Type 3277 Actuator)		NPT ¾		-		

1) Actuator 350 cm² without lifting ring

2) Minimum clearance for actuator disassembly

Table 8b · Weights of standard version in kg

Globe Valve	Size	in	½"	1"	1½"	2"	3"	4"	6"	8"
		mm	15	25	40	50	80	100	150	200
Weight, without actuator	Class 150/300	kg	15.5	17.5	21.5	38	59	78	201	427
	Class 600	kg	22	28	36	64	102	137	340	540
	Class 900	kg	35	41	60	97	120	160	380	650

Pneumatic Actuator	Size	350	700	1400	2800	2 x 2800	
	cm ²	350	700	1400	2800	2 x 2800	
Weight, Type 3271	Without	kg	8	22	70	450	950
	With handwheel	kg	13	27	Only with side-mounted handwheel, see T 8310		
Weight, Type 3277	Without	kg	12	26	-		
	With handwheel	kg	17	31	-		

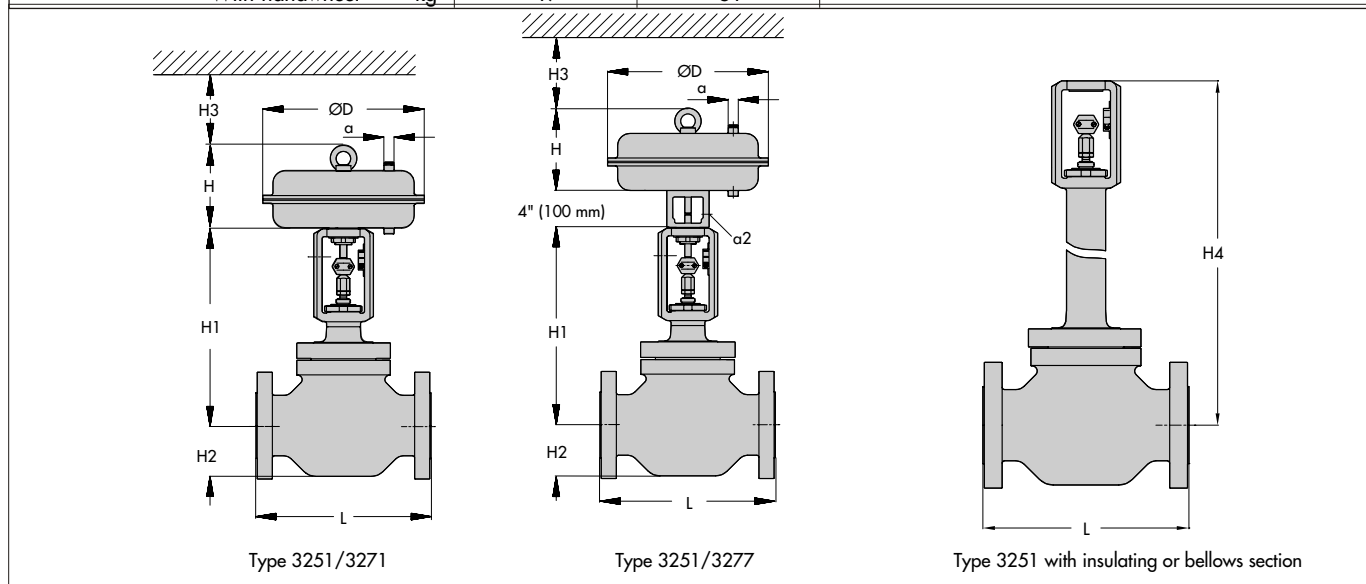

Table 9a · Dimensions and weights of standard version with insulating section in inches and lbs · Without actuator

Nominal size			½"	1"	1½"	2"	3"	4"	6"	8"	
Class 150 ... 600	54 in ² /350 cm ²	in	23.34	23.34	23.82	28.62	28.82	29.60	-		
	108 in ² /700 cm ²	in	23.34	23.34	23.82	28.62	28.82	29.60	42.64	53.74	
H4 for actuator	217 in ² /1400 cm ²	in	-				30.78	30.98	31.77	42.62	53.74
	434 in ² /2800 cm ²	in	-				-		39.05	45.98	57.08
Class 900	54 in ² /350 cm ²	in	24.48	24.48	24.84	29.76	28.82	29.60	-		
	108 in ² /700 cm ²	in	24.48	24.48	24.84	29.76	28.82	29.60	42.64	53.74	
H4 for actuator	217 in ² /1400 cm ²	in	-				31.93	30.98	31.77	42.64	53.76
	434 in ² /2800 cm ²	in	-				-		39.05	45.98	57.08
Weight, without actuator for	Class 150...600	lb	66.5	79.5	97	159	242.5	344	794	1411	
	Class 900	lb	95	108	150	231.5	287	397	882	1610	

Table 9b · Dimensions and weights of standard version with metal bellows in inches and lbs · Without actuator

Nominal size			½"	1"	1½"	2"	3"	4"	6"	8"	
Class 150	54 in ² /350 cm ²	in	23.23	23.23	23.7	32.9	33.1	33.1	-		
	108 in ² /700 cm ²	in	23.23	23.23	23.7	32.9	33.1	33.1	44.85	57.3	
H4 for actuator	217 in ² /1400 cm ²	in	-				35.1	35.3	35.3	44.85	57.3
	434 in ² /2800 cm ²	in	-				-		42.56	48.2	60.63
Class 300/600	54 in ² /350 cm ²	in	23.23	23.23	23.7	32.9	33.1	33.1	-		
	108 in ² /700 cm ²	in	23.23	23.23	23.7	32.9	33.1	33.1	50.1	73.1	
H4 for actuator	217 in ² /1400 cm ²	in	-				35.1	35.3	35.3	50.1	73.1
	434 in ² /2800 cm ²	in	-				-		42.6	53.4	76.4
Class 900	54 in ² /350 cm ²	in	22.95	22.95	23.35	32.5	33.1	33.1	-		
	108 in ² /700 cm ²	in	22.95	22.95	23.35	32.5	33.1	33.1	50.1	78.4	
H4 for actuator	217 in ² /1400 cm ²	in	-				34.7	35.3	35.3	50.1	78.4
	434 in ² /2800 cm ²	in	-				-		42.6	53.4	81.7
Weight, without actuator for	Class 150/300	lb	-						794		-
	Class 600	lb	66.5	80	97	159	243	344	794	1411	
	Class 900	lb	95	108	150	232	287	397	882	1610	

Table 10a · Dimensions and weights of standard version with insulating section in mm and kg · Without actuator

Nominal size		in	½"	1"	1½"	2"	3"	4"	6"	8"	
		mm	15	25	40	50	80	100	150	200	
Class 150 ... 600	54 in ² /350 cm ²	mm	593	593	605	727	732	752	-		
	108 in ² /700 cm ²	mm	593	593	605	727	732	752	1083	1365	
H4 for actuator	217 in ² /1400 cm ²	mm	-				782	787	807	1083	1365
	434 in ² /2800 cm ²	mm	-				-		992	1168	1450
Class 900	54 in ² /350 cm ²	mm	622	622	631	756	732	752	-		
	108 in ² /700 cm ²	mm	622	622	631	756	732	752	1083	1365	
H4 for actuator	217 in ² /1400 cm ²	mm	-				811	787	807	1083	1365
	434 in ² /2800 cm ²	mm	-				-		992	1168	1450
Weight, without actuator for	Class 150...600	kg	30	36	44	72	110	156	360	640	
	Class 900	kg	43	49	68	105	130	180	400	730	

Table 10b · Dimensions and weights of standard version with metal bellows in mm and kg · Without actuator

Nominal size		in	½"	1"	1½"	2"	3"	4"	6"	8"	
		mm	15	25	40	50	80	100	150	200	
Class 150	54 in ² /350 cm ²	mm	590	590	602	836	841	841	-		
	108 in ² /700 cm ²	mm	590	590	602	836	841	841	1139	1455	
H4 for actuator	217 in ² /1400 cm ²	mm	-				891	896	896	1139	1455
	434 in ² /2800 cm ²	mm	-				-		1081	1224	1540
Class 300/600	54 in ² /350 cm ²	mm	590	590	602	836	841	841	-		
	108 in ² /700 cm ²	mm	590	590	602	836	841	841	1271	1855	
H4 for actuator	217 in ² /1400 cm ²	mm	-				891	896	896	1271	1855
	434 in ² /2800 cm ²	mm	-				-		1081	1356	1940
Class 900	54 in ² /350 cm ²	mm	583	583	593	825	841	841	-		
	108 in ² /700 cm ²	mm	583	583	593	825	841	841	1271	1990	
H4 for actuator	217 in ² /1400 cm ²	mm	-				880	896	896	1271	1990
	434 in ² /2800 cm ²	mm	-				-		1081	1356	2075

Installation

Arbitrary mounting orientation. If the mounting orientation is inclined, the actuator and valve must be supported. Observe the clearance is adequate to allow actuator, bonnet and plug removal (H3 in the table of dimensions). Direction of flow as indicated by the arrow on the valve body.

Registered Trade Marks

Monel, Hastelloy, and Stellite are referred to within this publication with the understanding that the names are Registered Trade Marks of their respective owners, which include Cabot Wrought Products, International Nickel Co., Carpenter Technology, or the rightful owner, in the past as well as in future cases.

Selection and Sizing of Control Valve

1. Calculate the Cv (Kv) value according to ISA S75.01 or DIN IEC 534.
2. Select the nominal size and Cv (Kvs) value according to Table 3.
3. Determine the permissible differential pressure Δp according to Tables 4 and 6.
4. Select the valve body material according to Tables 1 and 2 and the Pressure-Temperature Diagrams in the Information Sheet T 8000-2.
5. Select options and accessories according to Tables 1 and 2.

Ordering information

Globe Control Valve Type 3251

Nominal size
Body material ASTM According to Table 2
Pressure rating ANSI Class
End connections: Flanges/welding ends
Cv /Kvs value Characteristic
Options/Special version

Actuator:

Type ... Ordering information ⁵⁾ ...
Fail-safe position ...

Operating conditions ²⁾:

Process fluid ³⁾ ... Flow rate ⁴⁾ ...
Inlet pressure ... Outlet pressure ⁴⁾ ...
Temperature ...
Maximum shutoff Δp for actuator sizing ...
Air/power supply available for actuator, max./min. ...

Accessories:

Positioner, Switches, Transmitter, Solenoid valve,
Filter/regulator,
Bypass, Volume/pressure amplifier, Lockup relay ...
Type ... Ordering information ⁵⁾ ...
Tubing and fittings type/material ...

Other instrumentation:

Controllers, Sensors, Transmitters, Transducers, Converters ...
Type ... Ordering information ⁵⁾ ...

Notes:

- ¹⁾ If nominal size or Cv/Kvs value unknown, specify operating conditions
- ²⁾ Specify system of units, pressures: specify gauge or absolute. Provide minimum, normal, and maximum values, where applicable. Gases, vapors: specify flow rate under standard or actual conditions
- ³⁾ Non-standard process fluids, specify additionally:
Density, Specific gravity, or Molecular weight ...
Liquids: Vapor pressure, Critical pressure, Viscosity ...
Gases, Vapors: Ratio of specific heats, Compressibility factor
- ⁴⁾ Or, specify required valve flow coefficient Cv, Kvs ...
- ⁵⁾ Ordering information per the applicable Technical Data Sheet.

Specifications subject to change without notice.



SAMSON CONTROLS INC.
1 - 105 Riviera Drive
Markham · Ontario · Canada · L3R 5J7
Tel. (905) 474-0354 · Telefax (905) 474-0998
www.samsoncontrols.com

SAMSON CONTROLS INC.
4111 Cedar Boulevard
Baytown · Texas · USA · 77520-8588
Tel. (281) 383-3677 · Telefax (281) 383-3690
www.samson-usa.com

T 8052
T 8052CA