

Application

Single-acting or double-acting electropneumatic positioner for attachment to pneumatic control valves. Supplied with a standardized electric input signal in the range of 4 to 20 mA. Intelligent instrumentation according to the HART® FIELD COMMUNICATIONS PROTOCOL.

Rated travels from 7.5 to 120 mm and opening angle up to 120°



The microprocessor-based electropneumatic positioner ensures a pre-selected correspondence between the valve stem position (controlled variable x) and the electric input signal supplied by the controller (reference variable w). It compares the 4 to 20 milliamperereference input signal received from the control device to the travel of the control valve and, depending on the comparison, produces the corresponding pneumatic output signal pressure p_{st} (output variable y). The output from the positioner is the input signal to the actuator.

Suitable for attachment to both linear and rotary actuators.

The Type 3780 HART Positioner is equipped with an interface abiding to the **HART® (Highway Addressable Remote Transducer) FIELD COMMUNICATIONS PROTOCOL**, enabling connection to a PC or a HART®-compatible hand-held communicator (configurator) for bi-directional data communication. The operating program IBIS (Intelligent Operating Information System) complies with the standardized user menu interface according to VDI/VDE 2187. This HART Positioner can, however, also be operated with other suitable program packages.

The digital data processing feature offers the following benefits compared to conventional positioners without such capabilities:

- Automatic adjustment of ZERO and SPAN as the positioner is being initialized
- Automatic detection of errors in the actuator or in the pneumatic system
- Operating direction selectable via software functions and therefore independent of the mounting position
- Selectable characteristics
- Simple modification of control parameters, even when being operated
- Monitoring and diagnostic functions, such as self-test functions for fault alarm output, software limit switches and position indicator; total valve travel (travel integral)
- Continuous monitoring and adjustment of zero
- Minimum air consumption
- Permanent storage of all parameters in non-volatile EEPROM (protected against power failure)



Fig. 1 · Type 3780 HART Positioner

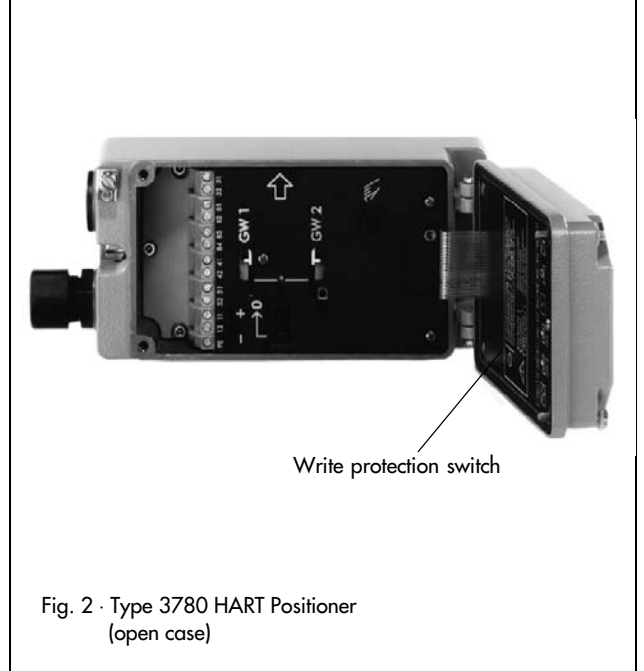

Fig. 2 · Type 3780 HART Positioner (open case)

Principle of operation (Figs. 3 and 4)

The travel of the final control element is detected via the non-contact inductive displacement sensor (1) and transmitted to the microcontroller (2) via a converter. In the microcontroller, the travel is compared to the setpoint, and the two pneumatic 2/2-way switching valves (3, 4) are activated whenever a deviation (i.e., error) occurs. Depending on the error, these valves either add air to (3) or vent air from (4) the pneumatic actuator via corresponding amplifiers (boosters).

A second microcontroller (5) manages the communication according to the HART® FIELD COMMUNICATIONS PROTOCOL. The Frequency Shift Keying (FSK) signal used for the communication is superimposed upon the standardized electric current signal.

The software package IBIS enables tuning and selection of all the required parameters and downloads these to the positioner. Subsequently, the positioner is able to operate independent of the PC or the hand-held communicator.

As a standard feature, the positioner is provided with a fault alarm output, used to signalize various errors and other relevant messages.

A locking switch located on the inside of the cover prevents saved configurations from being overwritten unintentionally.

Accessories

Options for extending function range of the positioner include:

- Two inductive limit switches (proximity switches) or two software limit switches, the latter being configured via the program
- One analog position transmitter which, independent of the reference input signal, converts the valve stem position into an analog output signal (operating direction can be configured via the software)
- Forced fail-safe venting function (safety trip) which, upon absence or loss of an external signal, vents air from the actuator accordingly via the 3/2-way valve (4). As a result, the control valve is forced to move in the pre-determined fail-safe position.

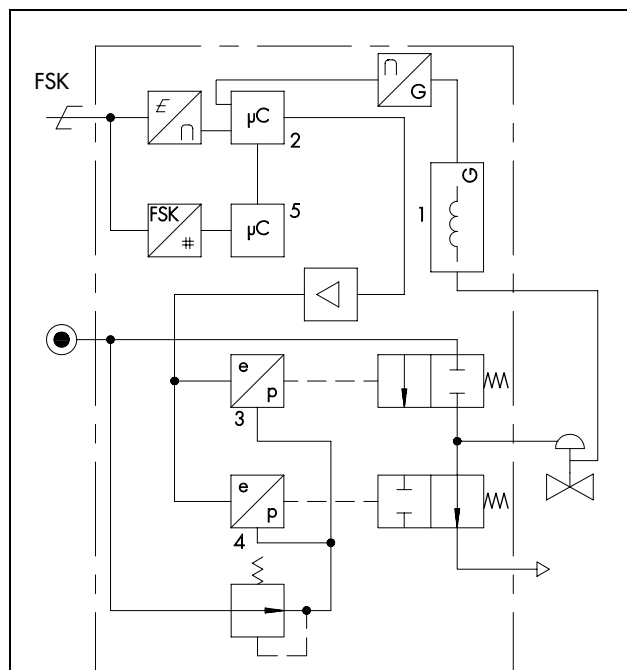

- | | |
|---------------------------------|---|
| 1 Inductive displacement sensor | 4 3/2-way valve |
| 2 Microcontroller | 5 Microcontroller |
| 3 3/2-way valve | FSK Frequency Shift Keying signal for communication |

Fig. 3 · Functional diagram of the Type 3780 HART Positioner

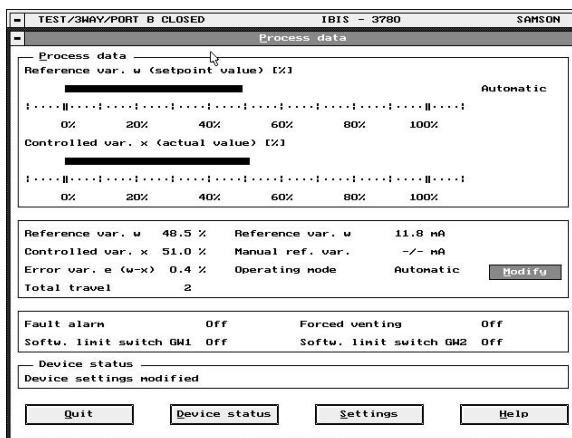

Fig. 4 · Display of the process values by means of the program package IBIS (Intelligent Operating and Information System)

Table 1 · Technical Data

Travel Attached to Type 3277: Attached acc. to DIN IEC 534 (NAMUR):	Adjustable 7.5 to 30 mm 7.5 to 120 mm or 30 to 120° with rotary-motion actuators
Reference input signal w Minimum current Internal load voltage	Signal range 4 to 20 mA, span 4 to 16 mA 3.6 mA ≤ 10.8 V (corresponds to 540 Ω at 20 mA)
Supply air	1.4 to 6 bar (20 to 90 psi)
Pneumatic output signal pressure	0 bar to capacity of supply air pressure
Characteristic	Adjustable: linear/equal percentage/reverse equal percentage/user-programmable Deviation from characteristic ≤ 1 %
Dead band	Adjustable from 0.1 to 10%, pre-defined 0.5%
Resolution	≤ 0.05%
Transit time	Separately adjustable for exhaust and supply air up to 240 s
Operating direction	Reversible, selection via software
Air consumption	Independent of supply air < 90 l _n /h
Air output capacity	Add air to actuat. For p = 6 bar: 9.3 m _n ³ /h, at p = 1.4 bar: 3.5 m _n ³ /h Vent air from actu. For p = 6 bar: 15.5 m _n ³ /h, at p = 1.4 bar: 5.8 m _n ³ /h
Permissible ambient temperature	-20 to 60 °C, extended temperature range on request
Temperature influence	≤ 0.15 %/10 K
Supply influence	None
Effect of vibration	None up to 250 Hz and 4 g
Explosion protection	EEx ia IIC T6 (see Table 3)
Degree of protection	IP 54, (IP 65 special version)
Electromagnetic compatibility	Requirements met according to EN 50081/50082
Weight	approx. 1.3 kg
Fault alarm output	For connection to NAMUR signal converter according to DIN 19 234
Communication	
Hardware requirements	IBIS program package: XT or AT-compatible PC, MS DOS 3.2 or later with FSK modem (RAM ≥ 580 kByte) or hand-held communicator, e.g. Type 275 by Fisher Rosemount
Data transmission	HART® Field Communication Protocol Impedance in HART frequency range: Receive 350 to 450 Ω, Send approx. 115 Ω
Software requirements for:	PC: IBIS program package · Hand-held communicator: Device Description for Type 3780
Software functions	Automatic start-up; Adjustment of: characteristic, moving direction, reference input signal range and transit time; limitation of the travel range; cross-over correction; automatic zero correction; fault alarms; total valve travel (travel integral); diagnostic messages; device information; non-volatile storage of data; test functions; logging via IBIS
Accessories	
Inductive limit switches	For connection to NAMUR signal converter according to DIN 19 234, two inductive proximity switches Type SJ 2 SN
Software limit switches	For connection to NAMUR signal converter according to DIN 19 234, two configurable limit values
Analog positioner Output Characteristic Hysteresis Ripple content of DC signal Operating range Supply Permissible load	Two-wire transmitter 4 to 20 mA ; operating direction reversible linear (deviation ≤ 1%, incl. influence of mechanical deflection for NAMUR attachment) ≤ 0.3 % 0.6 % at 28 Hz/IEC 381 T1 -10 to +114 % 12 to 35 V DC $R_B = \frac{U_S - 12 V}{20 mA}$
Resolution High-frequency influence Auxiliary energy influence Temperature influence	≤ 0.05 % < 2 % at 50 to 80 MHz none as positioner
Forced fail-safe venting function Input K _V value	6 to 24 V DC, R _i approx. 6 kΩ, switching point approx. 3 V 0.17

Table 2 · Materials (WN = Material Number according to DIN)

Case	Die-cast aluminum, chromized and plastic coated
External parts	Stainless steel WN 1.4571 and WN 1.4301

Table 3 · Data which additionally apply to the explosion-proof Type 3780-1.... HART Positioner

	Signal circuit	Position transmitter	Forced fail-safe venting action	Inductive limit switches Type 3780-12	Software limit switches Type 3780-13	Fault alarm output
U ₀	28 V			15.5 V	20 V	
k	115 mA			52 mA	60 mA	
P	1 W		500 mW	169 mW	250 mW	
C _i	5.3 nF		Negligibly small	40 nF	5.3 nF	
L _i	Negligibly small			60 μH	Negligibly small	
Ambient temperature range	Type 3780-1: -20 to +60 °C Extended temperature range on request					

Summary of the approved explosion protection certifications for the Type 3780-1 HART Positioner

Certificate type	Certificate number	Date	Comments
Certificate of Conformity	PTB no.: Ex-94.C.4069	9.11.94	EEx ia IIC T6
First addendum		14.10.96	Changes in construction

The test certificates are included in the "Mounting and operating instructions" and are available on request.

Connecting the HART Positioner

(Figs. 5 to 7)

The Type 3780 HART Positioner can be operated as a single unit (point-to-point communication), in multi-drop mode or on the FSK bus. Figs. 5 to 7 exemplify how the unit is to be interfaced. Isolating amplifiers in explosion-proof design (4) are only required when Type 3780 HART Positioner is used in hazardous areas. FSK bus connection always requires isolating amplifiers (TET 128 or TET 128-Ex).

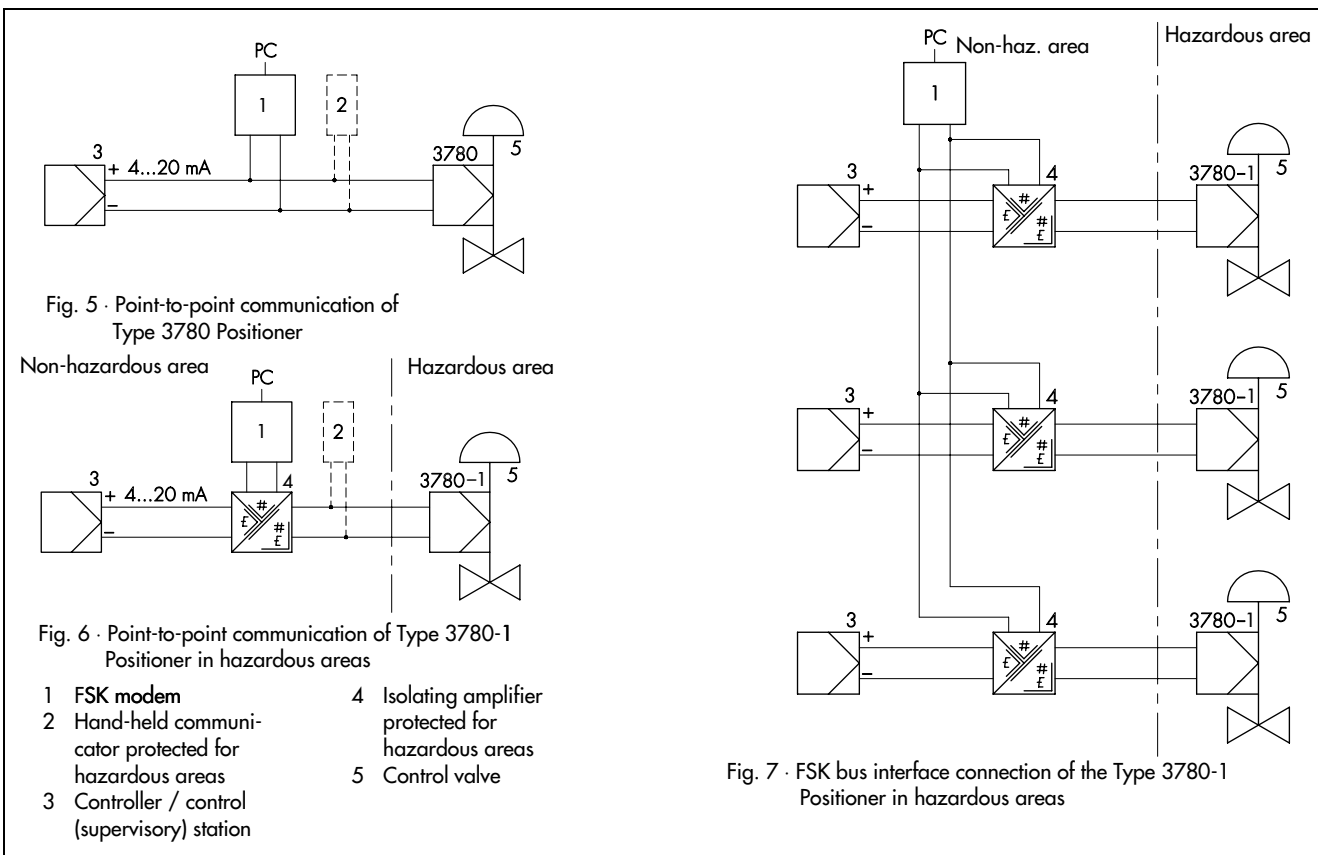

Attaching the positioner to the actuator

The Type 3780 HART Positioner can be mounted directly to the linear-motion Type 3277 Actuator using a connection block. For actuators employing fail-safe action "Actuator stem extends" and Type 3277-5 (effective area 120 cm²), the loading pressure is internally introduced to the diaphragm chamber through a hole resident in the actuator yoke. For actuators employing fail-safe action "Actuator stem retracts" and effective areas of 240 cm² or more, the loading pressure is externally introduced to the diaphragm chamber via a pre-fabricated outer tube connection.

With the use of an adapter plate, the positioner can also be easily attached to either side of the actuator according to DIN IEC 534 (NAMUR recommendation).

Attachment to the Type 3278 Rotary Actuator or other rotary-motion actuators according to VDI/VDE 3845 requires an intermediate piece. The rotary motion of the actuator is converted into a linear motion via a cam disk. This cam is designed for an angle corresponding to either 0 to 90° or 0 to 120°. The preferred characteristic can be selected via software.

For double-acting springless (no spring return) actuators, a reversing amplifier is required for producing the two opposed signal pressures.

Dimensions in mm

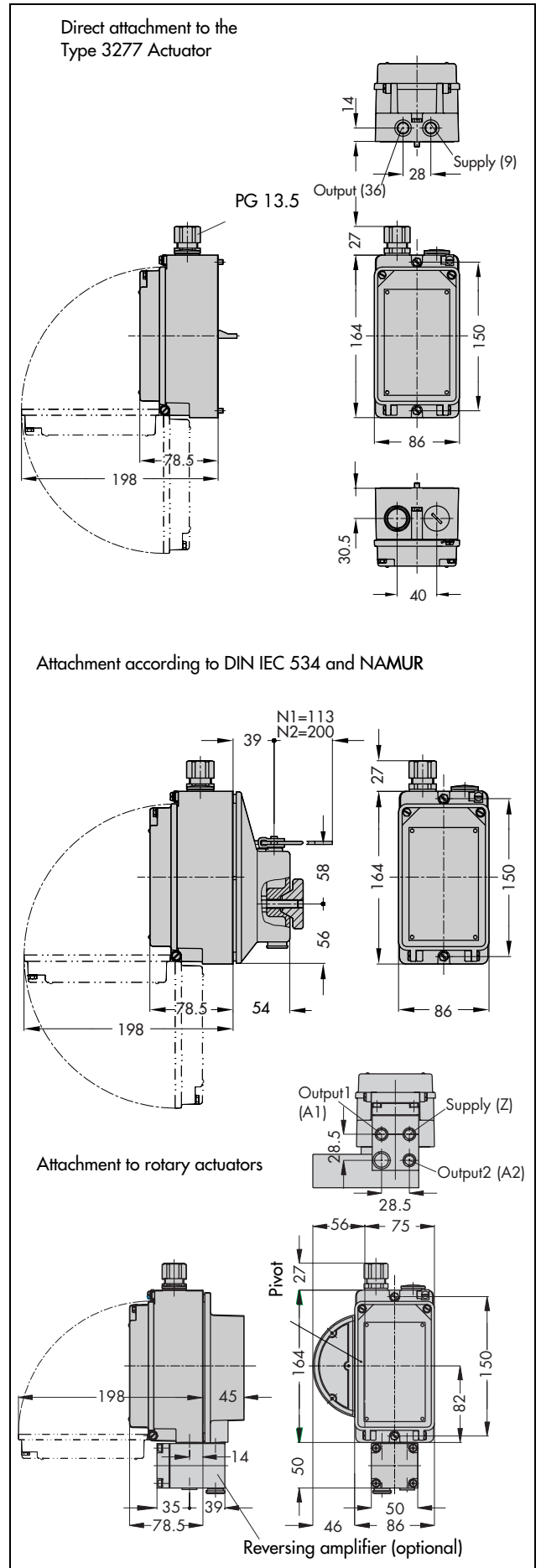

Electrical connection

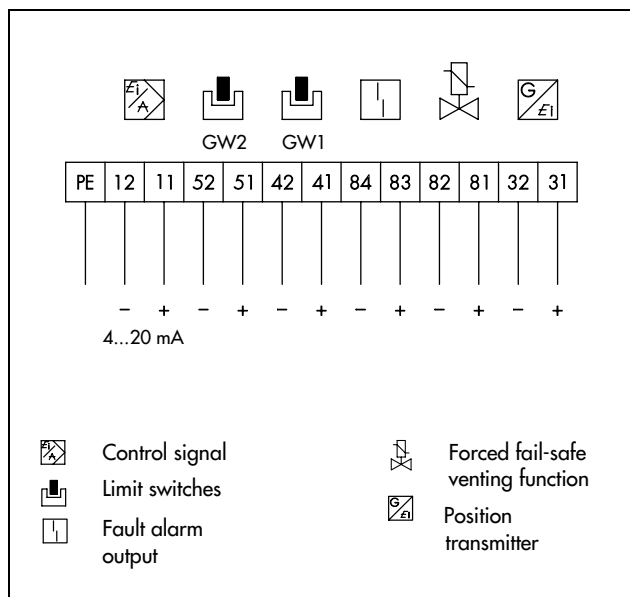

Nomenclature for ordering

Type designation: Type 3780 -

Explosion protection

Without

With (EEx ia IIC)

Accessories

Limit switches

Without

2 inductive

2 software

Forced fail-safe venting action

Without

With

Position transmitter

Without

4 to 20 mA

Pneumatic connections

1/4 - 18 NPT

ISO 228/1 - G1/4

Electrical connections

PG 13.5 (blue)

PG 13.5 (black)

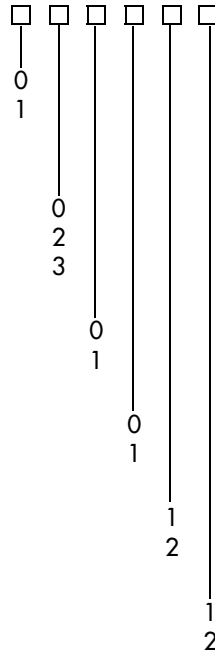

Ordering text

HART Positioner Type 3780-.....

(see nomenclature)

Optional IBIS program package, FSK modem, isolating amplifier TET 128/ TET 128-Ex

Without/with pressure gauge for monitoring the signal pressure

For positioners with limit switches:

Metal tag outside active zone (contact closed)/

Metal tag inside active zone (contact opened)

Attachment to Type 3277 Actuator:

Actuator sizes 120/ 240/ 350/ 700 cm², fail-safe action (spring return): Actuator stem "extends"/Actuator stem "retracts"

Side attachment according to DIN IEC 534 (NAMUR)

Travel: ... mm; if applicable, stem diameter: ... mm; if applicable, control pressure throttling for actuators with small travel volume

Attachment to rotary actuators:

Type 3278 Rotary Actuator, actuator sizes 160/ 320 cm²

Attachment to single-acting/double-acting rotary actuators according to VDI/ VDE 3845; if applicable, control pressure throttling for actuators with small travel volume



SAMSON CONTROLS INC.

1 - 105 Riviera Drive

Markham · Ontario · Canada · L3R 5J7

Tel. (905) 474-0354 · Telefax (905) 474-0998

SAMSON CONTROLS INC.

4111 Cedar Boulevard

Baytown · Texas · USA · 77520-8588

Tel. (281) 383-3677 · Telefax (281) 383-3690

T 8380 EN

T 8380 CA