

# Series 43 Temperature Regulators

SAMSON

**Type 43-1**

**Type 43-2**



Type 43-1 · Special version  
with stainless steel body



Type 43-2 · Special version  
with flanged body



Type 43-2 · Version with  
screwed ends

## Mounting and Operating Instructions

**EB 2171 EN**

Edition May 2015



## Definition of signal words



### **DANGER!**

*Hazardous situations which, if not avoided, will result in death or serious injury*



### **WARNING!**

*Hazardous situations which, if not avoided, could result in death or serious injury*



### **NOTICE**

*Property damage message or malfunction*



### **Note:**

*Additional information*



### **Tip:**

*Recommended action*

<b>1</b>	<b>General safety instructions</b> .....	<b>4</b>
<b>2</b>	<b>Process medium and scope of application</b> .....	<b>5</b>
2.1	Transportation and storage .....	5
<b>3</b>	<b>Design and principle of operation</b> .....	<b>6</b>
3.1	Version with safety thermostat .....	6
3.2	Version with double adapter .....	6
<b>4</b>	<b>Installation</b> .....	<b>8</b>
4.1	Temperature sensor .....	8
4.1.1	Capillary tube .....	9
4.2	Strainer (filter).....	9
4.3	Additional components .....	10
<b>5</b>	<b>Operation</b> .....	<b>10</b>
5.1	Start-up.....	10
5.2	Adjusting the set point .....	10
<b>6</b>	<b>Maintenance – Replacing parts</b> .....	<b>12</b>
6.1	Cleaning or replacing the plug.....	12
<b>7</b>	<b>Customer inquiries</b> .....	<b>14</b>
<b>8</b>	<b>Nameplate</b> .....	<b>14</b>
<b>9</b>	<b>Technical data</b> .....	<b>15</b>
<b>10</b>	<b>Dimensions</b> .....	<b>16</b>
10.1	Dimension tables.....	17



### 1 General safety instructions

- The device must be mounted, started up or serviced by fully trained and qualified personnel only; the accepted industry codes and practices are to be observed. Make sure employees or third persons are not exposed to any danger.
- All safety instructions and warnings given in these mounting and operating instructions, particularly those concerning installation, start-up and maintenance, must be strictly observed.
- According to these mounting and operating instructions, trained personnel refers to individuals who are able to judge the work they are assigned to and recognize possible dangers due to their specialized training, their knowledge and experience as well as their knowledge of the applicable standards.
- The devices comply with the requirements of the European Pressure Equipment Directive 2014/68/EU. Devices with a CE marking have a declaration of conformity, which includes information about the applied conformity assessment procedure. This declaration of conformity can be provided on request.
- To ensure appropriate use, only use the device in applications where the operating pressure and temperatures do not exceed the specifications used for sizing the device at the ordering stage.
- The manufacturer does not assume any responsibility for damage caused by external forces or any other external factors.
- Any hazards that could be caused in the temperature regulator by the process medium, operating pressure or by moving parts are to be prevented by taking appropriate precautions.
- Proper transport, storage, installation, operation and maintenance are assumed.



#### **Testing according to DIN EN**

*The **Type 43-1** and **Type 43-2** Temperature Regulators are tested by the German Technical Inspectorate (TÜV) according to DIN EN 14597 under the type designation 2750-0. The register number is available on request.*

## 2 Process medium and scope of application

Regulators for district heating systems, heat generators, heat exchangers and other HVAC and industrial applications.

For set points from **0** to **150 °C** · Valves **G ½** to **1** and **DN 15** to **50** · **PN 25** · Max. **200 °C** · Suitable for **liquids** up to **150 °C** and **non-flammable gases** up to **80 °C**

### 2.1 Transportation and storage

The devices must be carefully handled, transported and stored. Protect the devices against adverse influences, such as dirt, moisture or temperature outside the permissible ambient temperature range from **-20** to **+80 °C**.

### 3 Design and principle of operation

See Fig. 1.

The regulators consist of a Type 2431 K Globe Valve (Type 43-1) or a Type 2432 K Globe Valve (Type 43-2) and a Type 2430 K Control Thermostat with set point adjuster, capillary tube and a temperature sensor working according to the adsorption principle.



**Note:**

*Details on the Type 2430 K Thermostat with a temperature sensor working according to the vapor pressure principle ▶ EB 2430-3.*

The bodies are available made of red brass, spheroidal graphite iron or stainless steel.

See Data Sheet ▶ T 2176 for versions with double adapter or manual adjuster for the attachment of additional control thermostats.

The Type 2430 K Thermostat is attached to the valve body using the coupling nut.

The temperature regulators work according to the adsorption principle. The temperature of the measured medium creates a pressure in the temperature sensor which is proportional to the measured temperature. This pressure is transferred through the capillary tube (10) to the operating element (13) and converted into a positioning force. This force causes the pin of the operating element (12) to move the plug stem (4) with the plug (3) balanced by a piston.

By turning the set point adjuster (8), the point of response is changed over the valve spring (5).

The Type 43-1 and Type 43-2 Regulators are suitable for plants to be heated.

The valves close when the temperature rises.

#### 3.1 Version with safety thermostat

When a Type 2439 K or Type 2403 K Safety Thermostat is attached to the valve or the regulator, this combination functions as a safety temperature limiter (STL) or a temperature regulator with safety temperature limiter (TR/STL).

Details in mounting and operating instructions ▶ EB 2185 or ▶ EB 2083.

#### 3.2 Version with double adapter

The temperature regulator can be equipped with a double adapter to connect an additional thermostat to control a further control variable.

Details in mounting and operating instructions ▶ EB 2176.

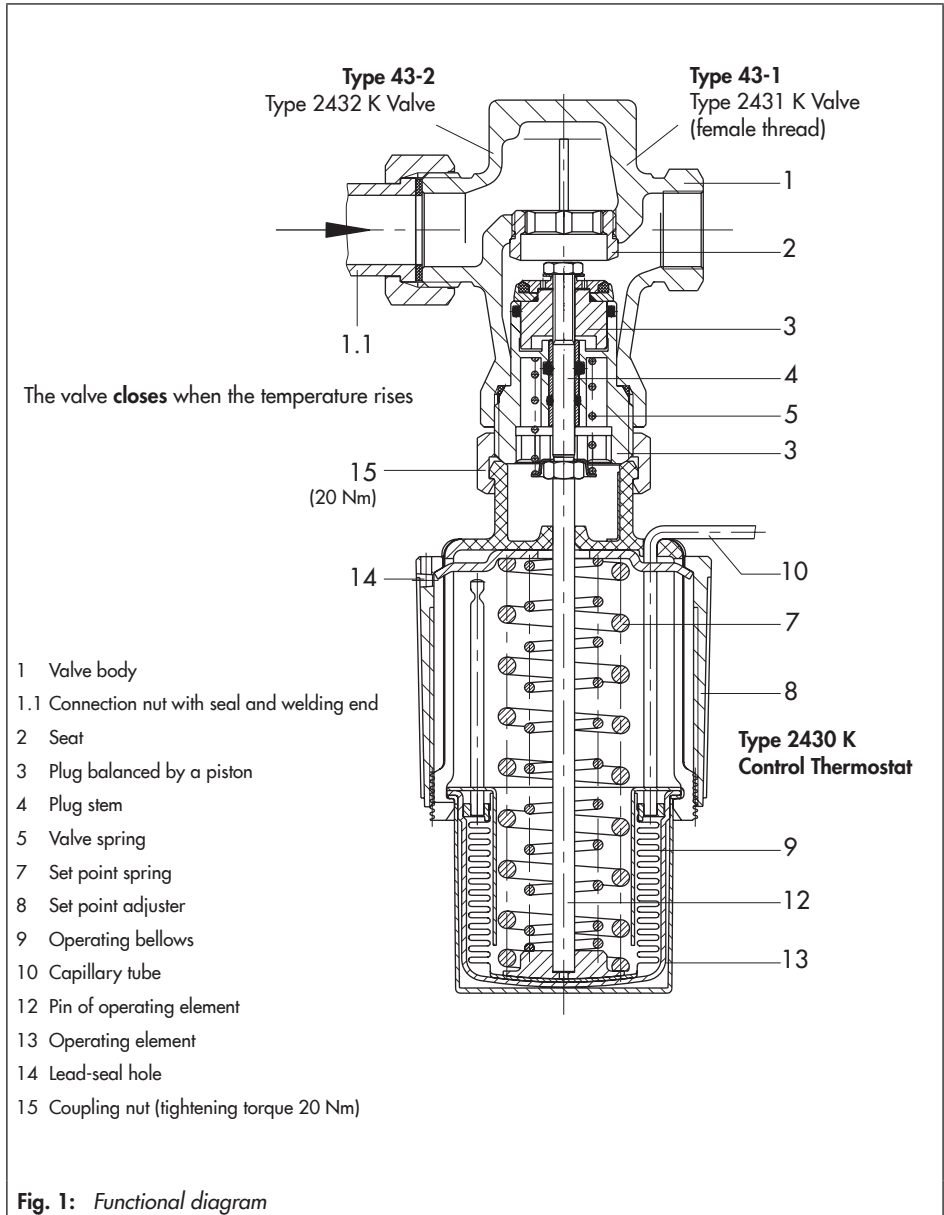

## 4 Installation

Choose a place of installation that allows you to freely access the regulator even after the entire plant has been completed. Make sure that the permissible ambient temperature does not fall below  $-20\text{ }^{\circ}\text{C}$  or exceed  $+80\text{ }^{\circ}\text{C}$ .

Flush the pipeline thoroughly before installing the regulator to ensure that any sealing parts, weld spatter and other impurities carried along by the process medium do not impair the proper functioning of the valve, above all the tight shut-off.

- Install the valve free of stress and with the least amount of vibrations as possible.
- The flow of direction must correspond with the direction indicated by the arrow on the valve body.
- The control thermostat must be suspended to hang downward. Other mounting positions are possible for temperatures up to  $110\text{ }^{\circ}\text{C}$ .



### NOTICE

*Malfunction and damage due to adverse effects of weather conditions (temperature, humidity). Do not install the temperature regulator outdoors or in rooms prone to frost. If such a location cannot be avoided, protect the regulator against freezing up if the process medium flowing through the valve can freeze up. Either heat the regulator or remove it from the plant and completely drain the residual medium.*

## 4.1 Temperature sensor



### NOTICE

*Galvanic corrosion due to incorrectly selected materials of the mounting parts.*

*On installing the sensor or thermowell, only combine the same kind of materials (e.g. stainless steel with stainless steel or copper together with other copper materials).*

The temperature sensor may be installed in any position even when a thermowell is used. However, make sure its entire length is immersed in the process medium to be controlled. It must be installed in a location where overheating or considerable idling times cannot occur.



### Note:

*If the sensor is to be used with a thermowell, only use original SAMSON thermowells.*

Weld a welding socket with G  $\frac{1}{2}$  or G  $\frac{3}{4}$  female thread (to match the screw gland) at the place of installation.

➔ Seal the screw gland of the sensor.

### Installation with thermowell

When a thermowell is used, a welding socket with G 1 female thread must be used.

➔ Seal the thermowell into the welding socket. Insert the sensor and tighten it with the clamping screw.



**Note:**

For temperature regulators with safety temperature limiter (TR/STL), install the sensor of the limiter near the sensor of the regulator.

### 4.1.1 Capillary tube

Carefully run the capillary tube without bending or twisting it. Avoid locations with considerable ambient temperature fluctuations along the entire length of the tube.

**Note:**

Do not damage or shorten the capillary tube. Roll up any capillary tube that is not used. The smallest permissible bending radius is 50 mm.

## 4.2 Strainer (filter)

Install the strainer upstream of the temperature regulator.

- The flow of direction must correspond with the direction indicated by the arrow on the body.
- The filter element must be installed to hang downwards.

**Tip:**

Remember to leave enough space to remove the filter element for cleaning.

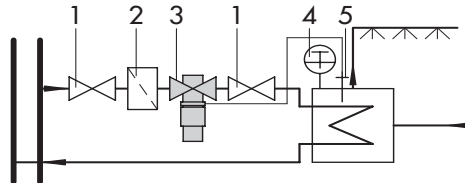

- 1 Shut-off valve
- 2 Strainer
- 3 Temperature regulator
- 4 Thermometer
- 5 Temperature sensor

Fig. 2: Installation example · Type 43-1 on a water-heated boiler

### 4.3 Additional components

We recommend installing a hand-operated shut-off valve upstream of the strainer and downstream of the regulator to be able to shut down the plant for cleaning and maintenance, and when the plant is not used for longer periods of time.

To check the adjusted set point, we recommend installing a thermometer immersed in the medium to be controlled near the sensor.

## 5 Operation

See Fig. 1.

### 5.1 Start-up

- Put the temperature regulator into operation after mounting the valve and control thermostat.
- Fill the plant slowly with the process medium (without pressure surges).  
Slowly open the hand-operated shut-off valve downstream of the valve and then the shut-off valve upstream of the valve.
- Check the adjusted temperature set point at the thermometer installed near the temperature sensor.

### 5.2 Adjusting the set point

To adjust the set point, turn the black plastic adjuster while watching the reference thermometer.

- Turn clockwise (↻) to reduce the temperature
- Turn counterclockwise (↺) to increase the temperature

The adjustment diagrams (see Fig. 3) can be used as a guide to find the first approximate value.



**Tip:**

Higher set point temperatures can be adjusted in increments as required. However, to lower the set point temperature, proceed in steps of 10 to 20 °C. When doing so, wait for the process medium to cool down before continuing. Watch the thermometer.

**Table 1: Set point ranges**

Set point range in °C	Set point change per turn	Sensor Ø
0 to 35 °C	2.5 °C	9.5 mm
	2 °C	16 mm
25 to 70 °C	3 °C	9.5 mm
	2 °C	16 mm
40 to 100 °C	4 °C	9.5 mm
	3 °C	16 mm
50 to 120 °C	4 °C	9.5 mm
	4.5 °C	16 mm
70 to 150 °C	4.5 °C	9.5 mm
	5 °C	16 mm

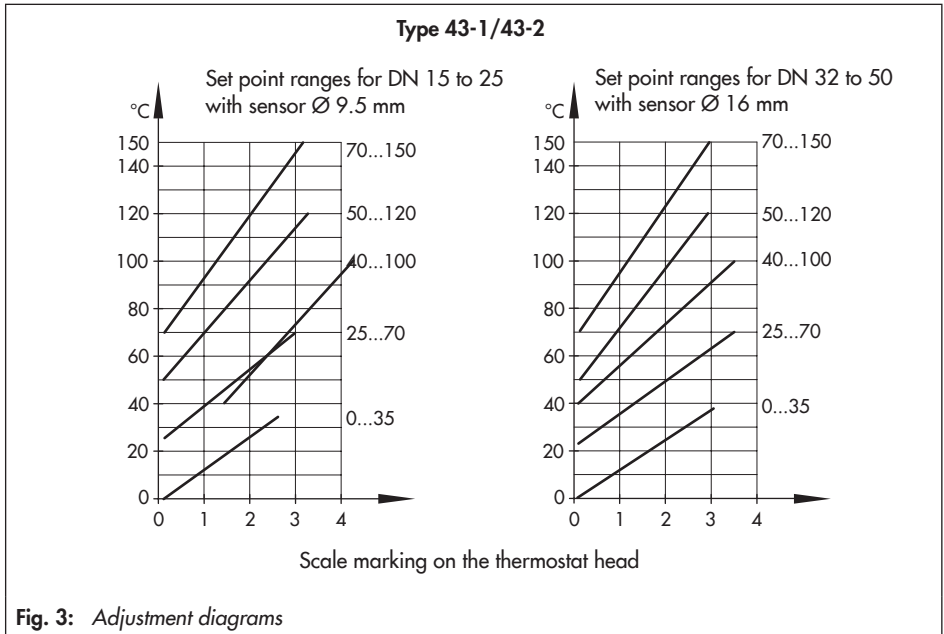

**Fig. 3:** Adjustment diagrams

### Dynamic behavior of Type 2430 K Control Thermostat

The dynamics of the regulator are mainly determined by the response of the sensor with its characteristic time constant.

The table shows the dynamic behavior of the Type 2430 K Thermostat measured in water.

**Table 2:** Dynamic behavior of Type 2430 K Thermostat

Type 2430 K	Sensor Ø in mm	Time constant [s]	
		Without Thermowell	With
Adsorption principle	9.5	15	40
	16	30	80
	Air sensor	8	– <sup>1)</sup>

<sup>1)</sup> Thermowell not possible

## 6 Maintenance – Replacing parts

See Fig. 1.

The temperature regulators do not require any maintenance. Nevertheless, they are subject to natural wear, particularly at the seat and plug.

Depending on the operating conditions, check the regulator at regular intervals to avoid possible malfunctions.

If the temperature exceeds the value adjusted at the temperature sensor, possible causes for this are:

- The thermostat is defective due to excessive temperatures.
- Valve seat and plug are contaminated with dirt.
- Seat and plug leak due to natural wear.

Before performing any work on the temperature regulator, we recommend removing the valve from the pipeline.



### **WARNING!**

*Risk of injury due to process medium escaping possibly under pressure. Depressurize the relevant section of the pipeline and, if necessary, drain it as well. When used at high temperatures, allow the plant section to cool down to ambient temperature.*

Exceptional operating and installation conditions can lead to changed situations that may affect the control response and lead to malfunctions. In such cases, check the instal-

lation conditions, process medium, temperature and pressure conditions.

For initial evaluation of faults and how to remedy them, refer to Table 3 on page 13.

### 6.1 Cleaning or replacing the plug

To change the plug section (3), a special plug wrench is needed:

For DN 15 to 25	Order no.: 1280-3001
-----------------	----------------------

For DN 32 to 50	Order no.: 1280-3007
-----------------	----------------------

To change the seat (2), a special seat wrench is needed:

For DN 15 to 25	Order no.: 1280-3012
-----------------	----------------------

For DN 32 to 50	Order no.: 1280-3013
-----------------	----------------------

The tools are available from SAMSON.

#### **Procedure**

1. Unscrew the coupling nut (15) and remove the control thermostat.
2. Use the plug wrench to pull out the entire plug section.
3. Thoroughly clean the seat (2) and plug (3). If the seat is damaged, it must be replaced using the seat wrench. If the plug is damaged, the entire plug section as well as the seal in the body must be renewed.

To reassemble, proceed in reverse order. If necessary, insert a new seal for the plug section into the body. Screw in the plug section (tightening torque approx. 80 Nm).

Connect the thermostat and valve using the coupling nut (15). Tightening torque approx. 20 Nm.

**Table 3: Troubleshooting**

Possible reasons	Recommended action
<b>Temperature at the sensor does not reach or exceeds the set point</b>	
Leak at seat and plug	Remove valve from the pipeline and clean seat and plug. Renew plug, if necessary. If this is not possible, return regulator to SAMSON for repair.
Size (DN or G) of the valve is too small or too large for the control task.	Recalculate $K_{VS}$ and install a suitably sized valve.
Sensor installed in the wrong location.	The entire length of the temperature sensor must be immersed in the process medium and where idle times or heat buildup cannot occur. Change mounting position accordingly.
A safety device (e.g. STL or STM) has been triggered.	Check plant. Unlock safety device (where necessary).
Insufficient heating or cooling energy available	Draw up an energy balance.
<b>Temperature at the sensor exceeds the set point</b>	
Thermostat defective	Replace thermostat (read specifications on the nameplate).
Insufficient heating energy available	Draw up an energy balance.
Strainer blocked	Drain and clean filter of the strainer.
The valve is not installed in the direction indicated by the arrow.	Install the valve in such a way that the flow of direction corresponds with the direction indicated by the arrow on the valve body.
<b>Control loop hunts · Very long dead time/sluggish control response</b>	
The valve (DN or G) is too large for control the task.	Recalculate $K_{VS}$ and install a suitably sized valve.
Time constant is too large for the control loop.	Fill the thermowell with thermal paste, remove thermowell or use sensor with smaller time constant.
Sensor installed in the wrong location.	The temperature sensor may be installed too far from the area where the temperature to be controlled arises. Locate the sensor closer to heat exchanger.
The valve is not installed in the direction indicated by the arrow.	Install the valve in such a way that the flow of direction corresponds with the direction indicated by the arrow on the valve body.

The table is not intended to be exhaustive as there are diverse reasons for malfunctions. In cases of doubt, contact SAMSON After-sales Service (see section 7).

## 7 Customer inquiries

Contact SAMSON's After-sales Service department for support concerning maintenance work or when malfunctions or defects arise.

Please send your inquiries to: [aftersaleservice@samson.de](mailto:aftersaleservice@samson.de)

The addresses of SAMSON AG, its subsidiaries, representatives and service facilities worldwide can be found on the SAMSON website (► [www.samson.de](http://www.samson.de)), in all SAMSON product catalogs or on the back of these Mounting and Operating Instructions.

To assist diagnosis, specify the following details:

- Type and nominal size of the valve, Type ... Thermostat
- Configuration ID (Var.-ID)
- Upstream and downstream pressure
- Temperature and process medium
- Min. and max. flow rate in m<sup>3</sup>/h
- Is a strainer installed?
- Installation drawing showing the exact location of the regulator and all the additionally installed components (shut-off valves, thermometer, etc.).

## 8 Nameplate

<b>SAMSON</b>		<b>1</b>
<b>2710 -</b>	<b>2</b>	<b>3</b>
<b>4</b>		<b>5</b>
<b>6</b>		<b>7</b>

### Explanations

- |                                     |  |
|-------------------------------------|--|
| <b>1</b> Type designation (valve)   | <b>5</b> Max. permissible temperature                      |
| <b>2</b> Configuration ID (Var.-ID) | <b>6</b> Nominal pressure (valve)                          |
| <b>3</b> Date of manufacture        | <b>7</b> Max. permissible differential pressure $\Delta p$ |
| <b>4</b> $K_{VS}/C_V$ coefficient   |  |

**Fig. 4:** Nameplate

## 9 Technical data

**Table 4:** Technical data · All pressures in bar (gauge)

Type 2431 K Valve (Type 43-1)   Type 2432 K Valve (Type 43-2)						
Type 43-1	G ½	G ¾	G 1	-		
K <sub>VS</sub> coefficient	3.6 <sup>1)</sup>	5.7	7.2	-		
Type 43-2	DN 15 <sup>2) 3)</sup>	DN 20 <sup>3)</sup>	DN 25 <sup>2) 3)</sup>	DN 32 <sup>3)</sup>	DN 40 <sup>3)</sup>	DN 50 <sup>3)</sup>
K <sub>VS</sub> coefficient	4 <sup>1)</sup>	6.3	8	12.5	16	20
<b>Type 43-1 · Type 43-2</b>						
Nominal pressure	PN 25					
Max. perm. differential pressure Δp	20 bar			12 bar		
Max. perm. valve temperature	150 °C					
Compliance	<b>CE · EAC</b>					

- 1) Special version with K<sub>VS</sub> 0.4, 1 or 2.5
- 2) Flanged body of stainless steel (special version)
- 3) Flanged body of spheroidal graphite iron (special version)

Type 2430 K Control Thermostat	
Set point range <sup>1)</sup>	Continuously adjustable: 0 to 35 °C, 25 to 70 °C, 40 to 100 °C, 50 to 120 °C or 70 to 150 °C
Capillary tube	2 m (5 m as special version)
Max. permissible temperature at sensor	50 K above the adjusted set point
Permissible ambient temperature range	-20 to 80 °C <sup>2)</sup>
Permissible pressure at sensor/thermowell	PN 25/PN 40
Compliance	<b>EAC</b>

- 1) Further set point ranges on request
- 2) **Caution!** At temperatures below freezing: ice formation may damage the plant and especially the valve

## 10 Dimensions

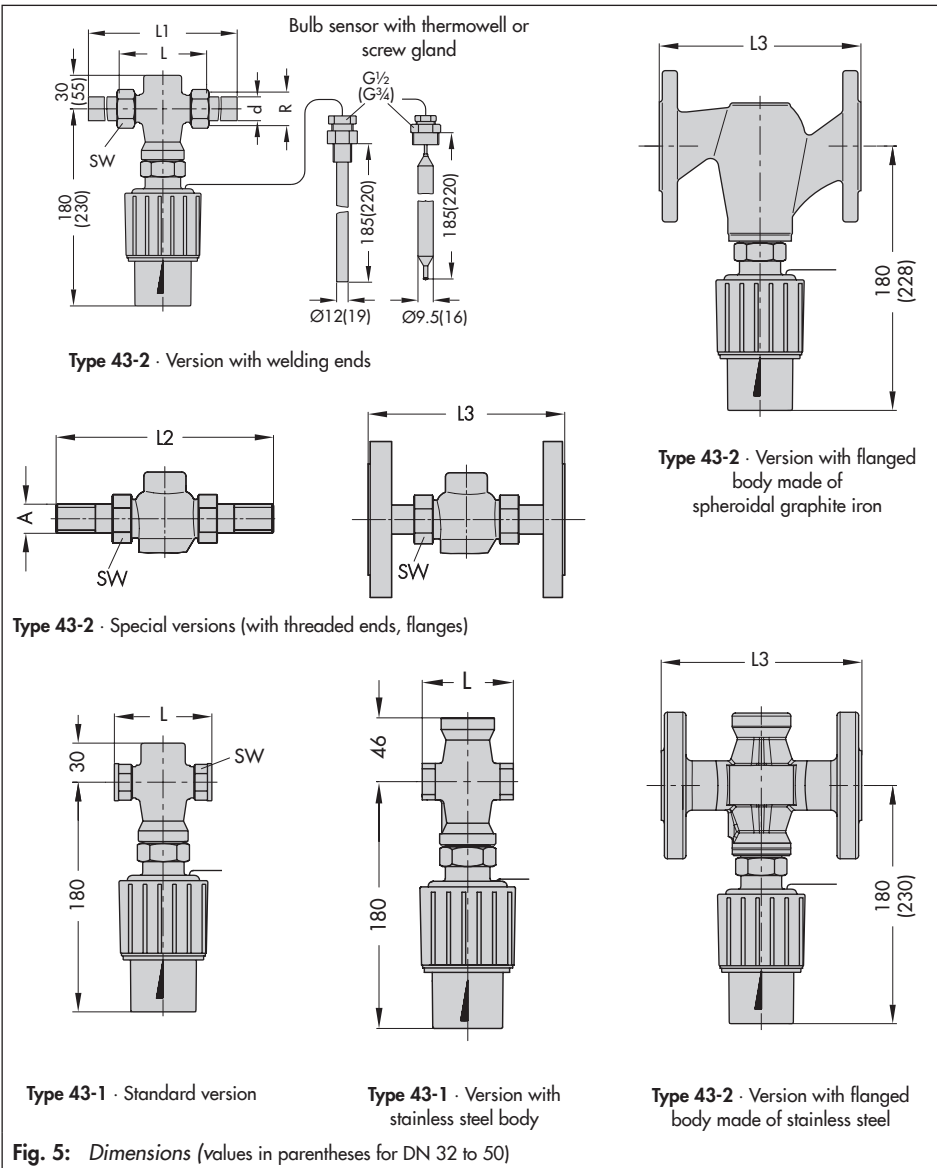

Fig. 5: Dimensions (values in parentheses for DN 32 to 50)



## 10.1 Dimension tables

Dimensions in mm and weights in kg

**Table 5:** Type 43-2 (DN 15 to 50)

Nominal size	DN 15	DN 20	DN 25	DN 32	DN 40	DN 50
Pipe Ø d	21.3	26.8	32.7	42	48	60
Connection R	G ¾	G 1	G 1¼	G 1¾	G 2	G 2½
Width across flats SW	30	36	46	59	65	82
Length L	65	70	75	100	110	130
L1 with welding ends	210	234	244	268	294	330
Weight, approx. <sup>1)</sup> (with bulb sensor and thermowell)	1.7 kg	2 kg	2.3 kg	4.4 kg	5.1 kg	5.9 kg
Special versions						
With <b>threaded ends</b> (male thread)						
Length L2	129	144	159	180	196	228
Male thread A	G ½	G ¾	G 1	G 1¼	G 1½	G 2
Weight, approx. <sup>1)</sup> (with bulb sensor and thermowell)	1.7 kg	2 kg	2.3 kg	4.4 kg	5.1 kg	5.9 kg
With <b>flanges</b> <sup>2)</sup> (PN 16/25)						
Length L3	129	144	159	180	196	228
Weight, approx. <sup>1)</sup> (with bulb sensor and thermowell)	3.1 kg	4 kg	4.8 kg	7.6 kg	9.1 kg/ 9.8 kg <sup>3)</sup>	11 kg/ 14.1 kg <sup>3)</sup>

<sup>1)</sup> Version without thermowell: minus 0.2 kg

<sup>2)</sup> Valve also with flanged body

<sup>3)</sup> Flanged body

**Table 6:** Type 43-1 (G ½ to 1)

Connection	G ½	G ¾	G 1
Length L	65	75	90
Width across flats SW	34	34	46
<b>Weight, approx. <sup>1)</sup></b> (with bulb sensor and thermowell)			
Type 43-1	1.4 kg	1.5 kg	1.6 kg

<sup>1)</sup> Version without thermowell: minus 0.2 kg







SAMSON AG · MESS- UND REGELTECHNIK  
Weismüllerstraße 3 · 60314 Frankfurt am Main, Germany  
Phone: +49 69 4009-0 · Fax: +49 69 4009-1507  
samson@samson.de · www.samson.de

**EB 2171 EN**

2015-08-19 · English