

Temperature Regulator with Hydraulic Controller Type 43-8



Fig. 1 · Type 43-8 for attachment to heat exchanger

Mounting and Operating Instructions

EB 2178 EN

Edition January 2007



General safety instructions



- ▶ *The regulators may only be mounted, started up or serviced by fully trained and qualified personnel, observing the accepted industry codes and practices. Make sure employees or third persons are not exposed to any danger. All safety instructions and warnings in these mounting and operating instructions, particularly those concerning assembly, start-up, and maintenance, must be observed.*
- ▶ *The control valves fulfil the requirements of the European Pressure Equipment Directive 97/23/EC. Valves with a CE marking have a declaration of conformity, which includes information about the applied conformity assessment procedure. The declaration can be viewed and downloaded on the Internet at <http://www.samson.de>.*
- ▶ *For appropriate operation, make sure that the temperature regulators are only used in areas where the operating pressure and temperatures do not exceed the operating values that are based on the valve sizing data submitted in the order.
The manufacturer does not assume any responsibility for damage caused by external forces or any other external influence!
Any hazards that could be caused in the temperature regulator by the process medium or the operating pressure are to be prevented by means of the appropriate measures.*
- ▶ *Proper shipping and appropriate storage are assumed.*

Important!

- ▶ *Do not start up the temperature regulators before the valve and control thermostat have been installed.*
 - ▶ *When disassembling the regulators, make sure the relevant section of the plant has been depressurized and drained.*
 - ▶ *Allow the plant to fill up slowly on start-up.*
-

1 Design and principle of operation

The Type 43-8 Regulator is used to control the temperature of instantaneous water heaters in small district heating stations.

The regulator comprises the Type 2430 K Control Thermostat operating on the vapor pressure principle, the Type 2438 K Hydraulic Controller as well as the Type 2432 K Control Valve.

In the sensor, the temperature generates a pressure corresponding to the actual value. The pressure is transmitted to the operating element (13) via the capillary tube (8). It is converted into a positioning force and compared to the force of the set point spring (10).

Based on the force ratio, the plug in the control valve (1) executes a linear movement. Depending on the travel, a smaller or larger annular gap opens up between the seat (2) and plug (3). The size of the gap determines the flow rate of the heating water. Increasing temperatures at the sensor cause the valve plug to close, reducing the flow rate of the heating water.

When hot water is tapped, a differential pressure of $\Delta p = p_1 - p_2$ is generated at the diaphragm plate (6). The resulting force opposes the force of the compression spring (7), which acts in closing direction – the valve opens. When tapping is completed, the pressure equilibrium is restored.

The force of the compression spring moves the valve plug in closing direction and the flow of heating water is interrupted. At the same time, the temperature set point of the thermostat is reduced by approx. 8 K (optionally 15 K) to a reduced idle temperature, thus preventing further heating followed by temperature peaks as well as

cooling-off of the supply lines. Hot water is immediately available on each tapping.

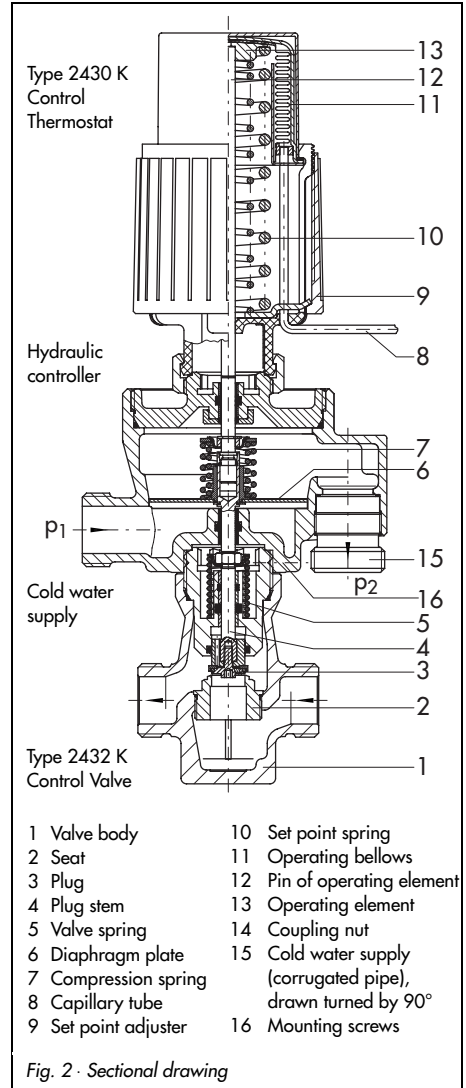

2 Installation

Make sure that the permissible ambient temperature of 35 °C is not exceeded at the place of installation.

The plate heat exchanger must be installed such that the heating water flows horizontally between the plates.

Heat exchanger connections:
for district heating supply pipe (heating water) and hot water on top,
for district heating return pipe (heating water) and cold water at the bottom.

Dimension H must be at least 260 mm.

2.1 Installing the valve

1. Plug housing of the hydraulic controller onto valve connection. Slightly tighten mounting screws such that the controller can still be rotated on the valve.
2. Mount valve with double nut (3) on heat exchanger and align them.
3. Screw in corrugated pipe (2) between controller and cold water supply of the heat exchanger using a tightening torque of 70 Nm.

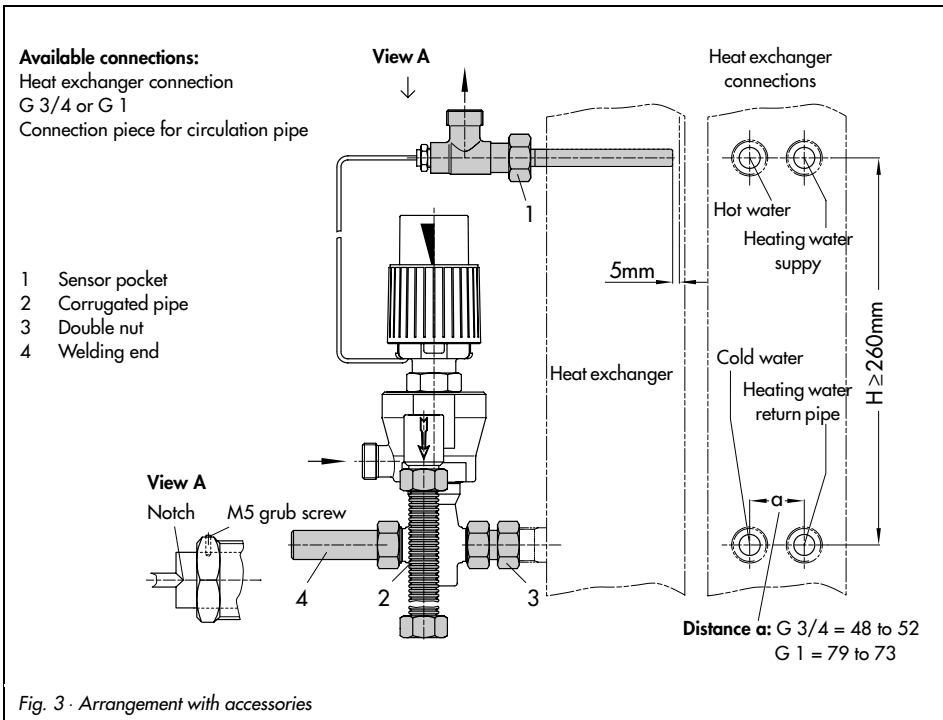

Fig. 3 · Arrangement with accessories

When integrating a circulation pipe, the necessary connection piece is available as an accessory. It is installed between the connection of the hydraulic controller and the corrugated pipe.

Older regulator versions are equipped with a capillary tube instead of the corrugated pipe. The capillary tube (Ø 18) may only be used as a replacement.

4. Tighten all three mounting screws on the side of the hydraulic controller.

2.1.1 Strainer

Install a strainer (SAMSON Type 1NI) upstream of the control valve to prevent that any sealing parts, weld spatter, and other impurities carried along by the process medium impair the proper functioning of the valve, above all the tight shut-off. The filter element must be vertically suspended. Remember to leave enough space to remove it.

2.1.2 Additional mounting instructions

We recommend to install a hand-operated shut-off valve both upstream of the strainer and downstream of the regulator to be able to shut down the plant for cleaning and maintenance, and when the plant is not used for longer periods of time.

To check the adjusted set point, it is recommended to install a thermometer that extends into the process medium near the sensor.

2.2 Temperature sensor

Important!

The temperature sensor must be installed without a thermowell!

To make good use of the fast response of the temperature sensor, the sensor must be installed at the best-suited point in the system.

For plate heat exchangers, this point is located immediately upstream of the hot water outlet of the heat exchanger.

Install the sensor pocket (1) for the temperature sensor such that the sensor projects horizontally into the hot water duct.

The notch at the sensor end must point upward (see Fig. 3, view A).

The sensor tip must be located at a distance of approx. 5 mm from the rear housing wall.

Align the sensor and secure it with an M5 grub screw.

Note!

In hot water heating plants with an instantaneous water system, no mixing faucet should be installed downstream of the temperature regulator as this can cause unstable temperature control.

3 Operation

3.1 Set point adjustment

Make sure that the permissible ambient temperature of 35 °C is not exceeded at the set point adjuster.

Use the black plastic ring (set point adjuster 9) to adjust the set point as indicated in the adjustment diagram.

- ▶ Turn clockwise to increase the temperature, and counterclockwise to reduce it.

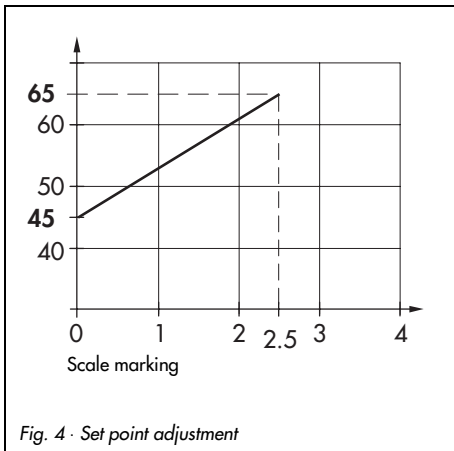

4 Description of the nameplate

1 Model number
 2 Index
 3 Date of manufacture
 4 Type designation

In the other fields:
 Kvs or cv value
 Max. permissible temperature °C or °F
 Max. permissible differential pressure Δp
 Nominal pressure PN or ANSI Class rating

Fig. 5 · Nameplate

5 Customer inquiries

Please include the following details when making inquiries:

- ▶ Device type and nominal size
- ▶ Model no. and order no.
- ▶ Pressures upstream and downstream of the valve
- ▶ Process medium and temperature
- ▶ Max. and min. flow rate
- ▶ Has a strainer been installed?
- ▶ Installation drawing
- ▶ Cold water supply over corrugated pipe or capillary tube
- ▶ With or without circulation pipe

6 Dimensions in mm

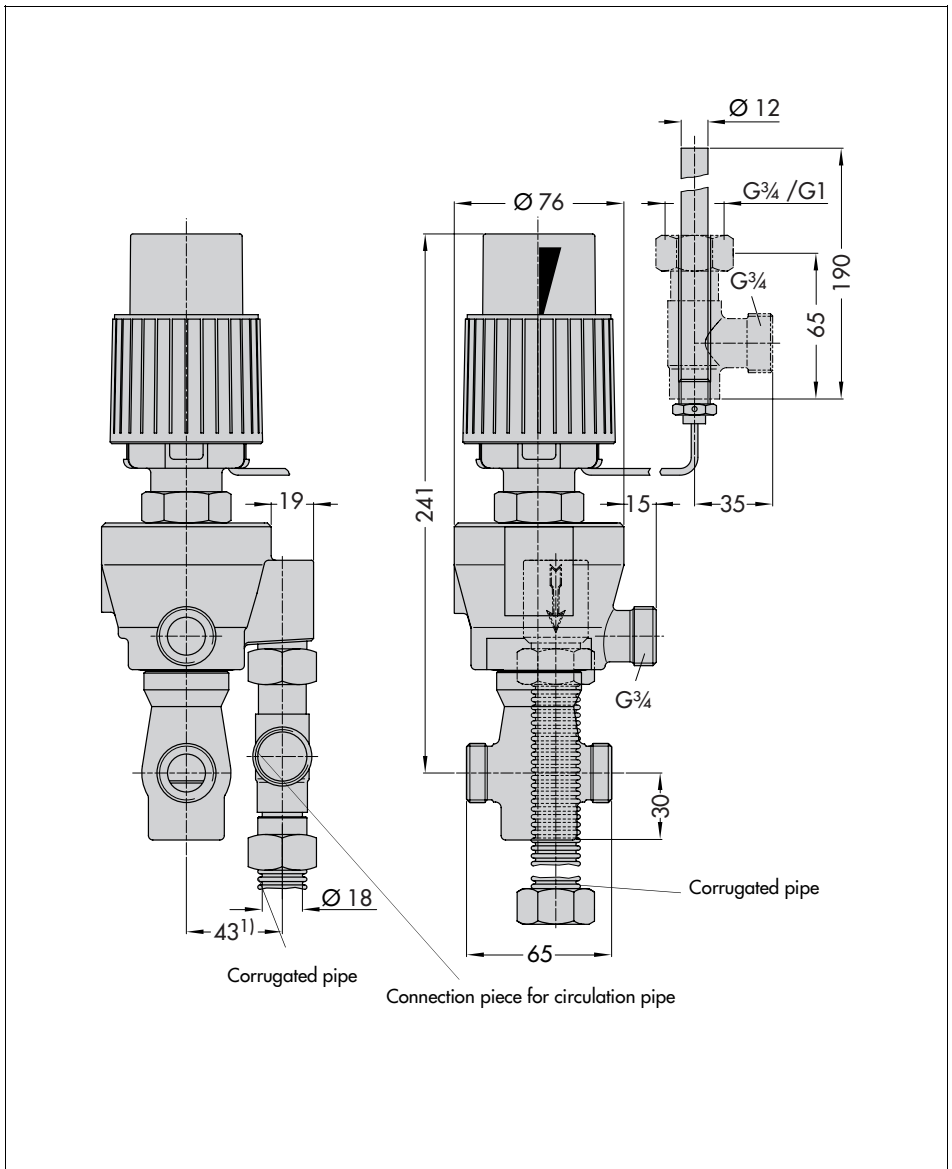



SAMSON AG · MESS- UND REGELTECHNIK
Weismüllerstraße 3 · 60314 Frankfurt am Main · Germany
Phone: +49 69 4009-0 · Fax: +49 69 4009-1507
Internet: <http://www.samson.de>

EB 2178 EN

S/Z 2007-10