

Safety Thermostat Type 2439 K



Fig. 1 · Type 2439 K Safety Thermostat

Mounting and Operating Instructions

EB 2185 EN

Edition March 2009



Contents	Page
1	Design and principle of operation 4
2	Installation 4
2.1	Installing the valve 5
2.2	Strainer 5
2.3	Additional installation instructions 5
2.4	Temperature sensor 5
2.4.1	Capillary tube 6
3	Operation 6
3.1	Adjusting the limit temperature 6
3.2	Unlocking the temperature limiter 7
4	Dimensions in mm 8



Typetesting

The safety thermostat is typetested by the German Technical Inspectorate (TÜV) according to DIN EN 14597 with the type designation Type 2750-1 .
Register number is available on request.

**General safety instructions**

- ▶ *The safety thermostat must be installed, started up, and serviced only by skilled or semi-skilled staff in accordance with good engineering practice so that employees and third persons are not exposed to danger.*
- ▶ *To ensure appropriate use, only use the safety thermostat in applications where the operating pressure and temperatures do not exceed the operating values specified in the order.
Note that the manufacturer does not assume any responsibility for damage caused by external forces or any other external factors.
Take appropriate safety precautions to prevent hazards that may be caused in the safety thermostat by the process medium or the operating pressure.*
- ▶ *Make sure the safety thermostat is shipped and stored properly.*

1 Design and principle of operation

The safety thermostat limits the temperature by closing and locking the valve connected to the thermostat.

The safety thermostat essentially consists of the housing with a spring mechanism and the thermostat with a capillary tube, bulb sensor and thermowell.

Typetesting

The safety thermostat has been typetested in combination with the valve as a safety temperature limiter (STL) with the type designation Type 2750-1 by the German Technical Inspectorate (TÜV) according to DIN EN 14597.

DIN register number is available on request.

By additionally connecting a second thermostat, the safety temperature limiter (STL) can be converted to a temperature regulator with a safety temperature limiter (TR/STL).

In both versions, the valve is connected directly to the spring mechanism of the safety thermostat. The spring mechanism locks the associated valve when the temperature reaches the adjusted limit value, the capillary tube ruptures, or the sensor system leaks. Resetting or re-commissioning can only be performed after the fault has been corrected and the temperature has fallen below the limit value.

2 Installation

The safety thermostat is always installed in plants in combination with a valve to form a safety temperature limiter (STL) or in combination with a regulator to form a temperature regulator with safety temperature limiter (TR/STL).

The housing of the spring mechanism can be secured to the valve body using a coupling nut before or after installing the valve (tightening torque of 20 Nm).

Adapters are available for older-type valve versions that use quick-fastening technique.

When installing, make sure that the permissible ambient temperature does not exceed 80 °C. In the case, an electric signal transmitter is used, the permissible ambient temperature of 60 °C applies.

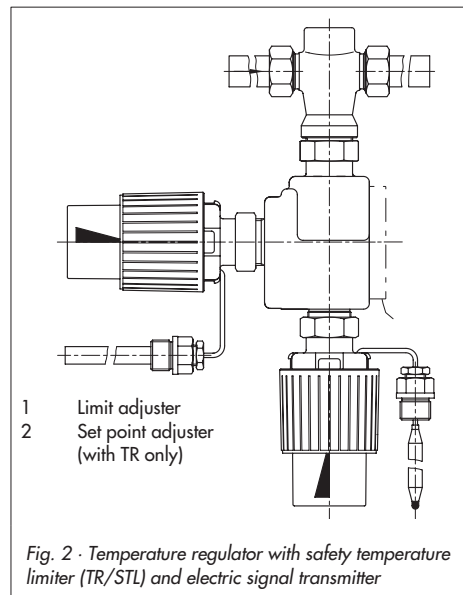

2.1 Installing the valve

Install the valve in a horizontal pipeline with the thermostat vertically suspended.

Make sure that the medium flows through the valve in the direction indicated by the arrow on the valve body.

For temperatures up to 110 °C, other mounting positions are possible for Types 2431, 2432, 2436, and 2433 Valves.

Further details can be found in the appropriate mounting and operating instructions of the relevant temperature regulator.

2.2 Strainer

Install a strainer (SAMSON Type 1 NI) upstream of the valve to prevent sealing particles, weld spatter, pipe scale, and other impurities carried along by the process medium from impairing the proper operation, especially the tight shut-off of the valve.

Install the strainer with the filter element suspended downwards.

Ensure that ample space is available to remove the filter.

2.3 Additional installation instructions

We recommend to install hand-operated shut-off valves both upstream of the strainer and downstream of the valve of the regulator/limiter. This allows the plant to be shut down for cleaning and maintenance routines, or when it is not operated for long periods of time.

To check the adjusted set point, we recommend that a thermometer be installed near the sensor. Make sure that the thermometer is completely immersed in the medium to be controlled.

2.4 Temperature sensor

The temperature sensor with its thermowell may be installed in any position. However, make sure its entire length is immersed in the process medium to be controlled. Select a place of installation where overheating and noticeable idle times will not occur.

Place the sensor of the limiter of temperature regulators with safety temperature limiters (TR/STL) near the temperature sensor.

NOTICE

Do not separate the thermostat of the safety temperature limiter (TR/STL) from the housing of the spring mechanism.

Install the sensor of the limiter using the supplied thermowell.

Weld a welding socket with G ½ female thread at the place of installation.

NOTICE

To prevent corrosion, only use identical or similar materials when installing the sensor or thermowell.

For example, do not insert a sensor or thermowell made of non-ferrous metal in a heat exchanger made of stainless steel. In this case, use a thermowell made of stainless steel for the sensor.

Seal the sensor with the thermowell into the welding socket.

2.4.1 Capillary tube

Install the capillary tube so that mechanical damage will not occur.

The minimum bending radius is 50 mm. Any excess length of the capillary tube must be rolled in a ring. Under no circumstances must the capillary tube be bent or shortened.

Make sure that the capillary tube is not exposed to considerable temperature fluctuations.

3 Operation

3.1 Adjusting the limit temperature

The safety temperature limiter is adjusted and lead-sealed to the value specified in the order. If another temperature is to be adjusted, turn the black plastic adjuster.

- ▶ Turn the adjuster clockwise to reduce the limit temperature
- ▶ Turn the adjuster counterclockwise to raise the limit temperature.

The adjustment diagram and table in Fig. 3 can be used as a guide to find the first approximate values.

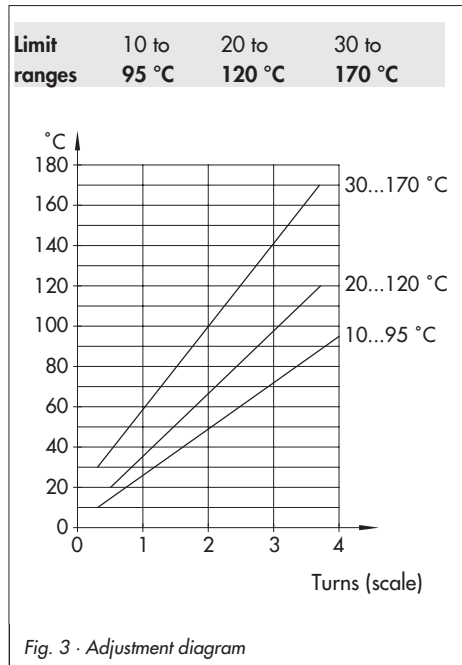

Fig. 3 · Adjustment diagram

After the limit temperature has been exactly adjusted for the first time, turn the set point adjuster counterclockwise to the maximum set point.

Expose the temperature sensor to a thermostatic bath at the corresponding limit temperature for at least five minutes. Afterwards, slowly turn the adjuster clockwise, decreasing the set point until the limit temperature is reached and the safety temperature limiter is triggered.

3.2 Unlocking the temperature limiter

The valve connected to the limiter is locked when the cam (marked red) is visible at the window of the spring mechanism housing.

After remedying the fault, unlock the limiter using a screwdriver. Insert the screwdriver into the window and press the cam downwards until it engages.

Note: The temperature limiter can only be unlocked after the temperature has fallen at least 15 K below the adjusted limit value!

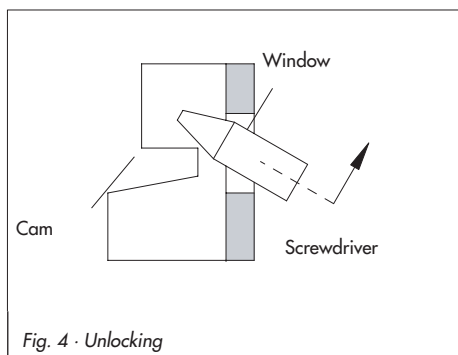

Fig. 4 · Unlocking

4 Dimensions in mm

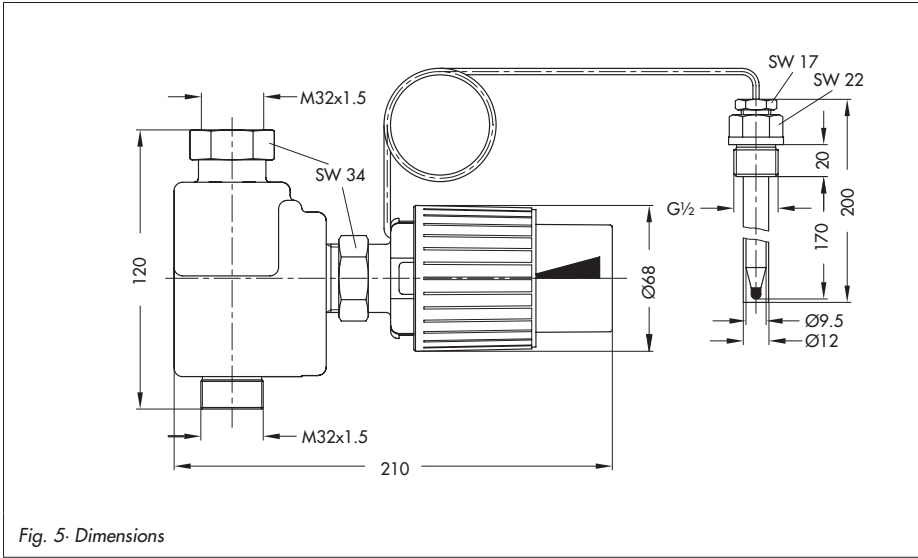

Fig. 5: Dimensions



SAMSON AG · MESS- UND REGELTECHNIK
Weismüllerstraße 3 · 60314 Frankfurt am Main · Germany
Phone: +49 69 4009-0 · Fax: +49 69 4009-1507
Internet: <http://www.samson.de>

EB 2185 EN

S/Z 2009-03