

# Temperature Regulator Series 43 Type 43-2 N



*Fig. 1 · Type 43-2 N*

## **Mounting and operating instructions**

**EB 2186 EN**

Edition July 2001

## 1. Design and principle of operation

### 1.1 Temperature regulator

The temperature regulator consists of the valve and the Type 2430 K Thermostat which are screwed together.

The valve comprises the valve body, seat and plug, the thermostat comprises operating bellows, set point spring, capillary tube and temperature sensor.

### 1.2 Version with double adapter and/or manual adjuster

For measurement of an additional process variable, the temperature regulator can be equipped with a double adapter plus an addi-

tional thermostat, or with a manual adjuster. For further details, refer to EB 2176 EN.

#### Principle of operation:

The temperature regulator works according to the adsorption principle. The temperature of the process medium produces a pressure in the sensor, which is proportional to the actual value. This pressure is transmitted via the capillary tube (10) to the operating element (13) and converted into a positioning force.

This force acts upon the operating bellows (9) and the operating element pin (12) and is passed on to the plug stem and plug (3). Turning the set point adjuster (8) changes the regulator's point of response via the spring (7). As a result, the valve plug passes through its travel range within a higher or



- ▶ *The device may only be assembled, started up and operated by trained and experienced personnel familiar with this product. According to these mounting and operating instructions, trained personnel is referred to as individuals who are able to judge the work they are assigned to and recognize possible dangers due to their specialized training, their knowledge and experience as well as their knowledge of the applicable standards.*
  - ▶ *Any hazards which could be caused by the process medium, the signal pressure and moving parts of the control valve are to be prevented by means of appropriate measures. In addition, it is necessary to make sure that the control valve is only used in areas where the operating pressure and temperatures do not exceed the operating values which are based on the valve sizing data submitted in the order.*
  - ▶ *Proper shipping and appropriate storage are assumed.*
-

lower temperature range sensed by the sensor.

**Note:** For thermostats working according to the vapor pressure principle, refer to EB 2430-3 EN.

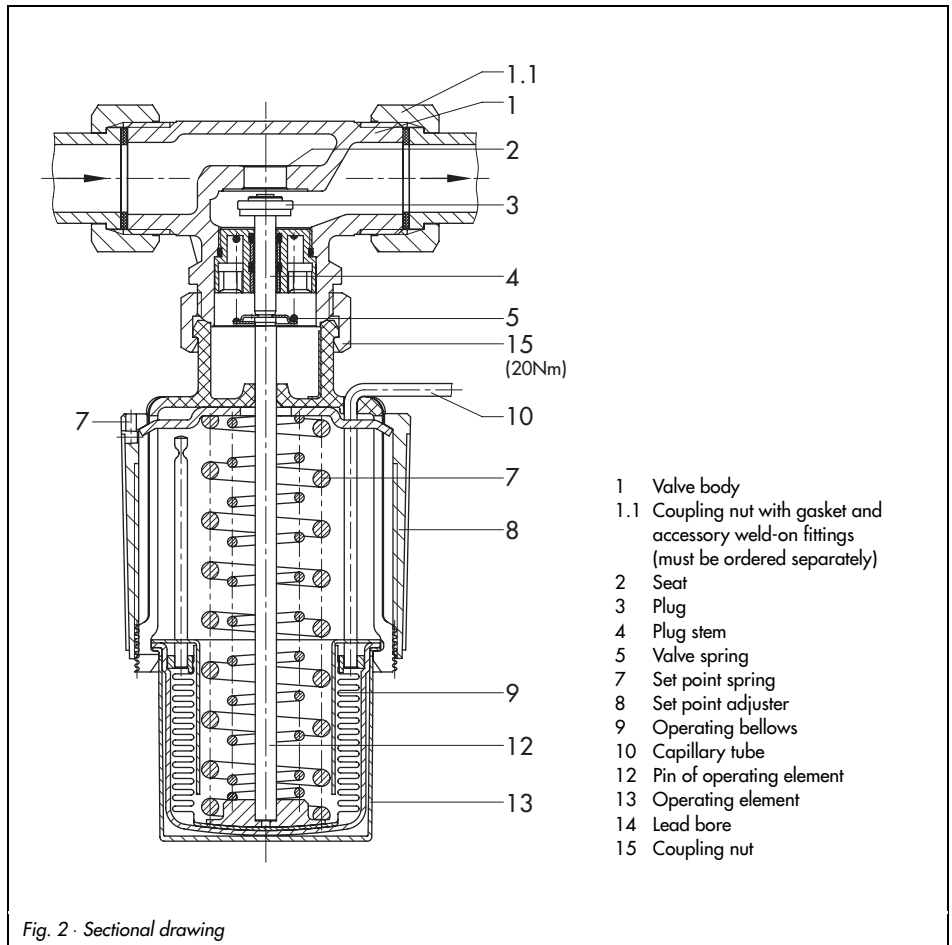

## 2. Installation

On installing the regulator, make sure that the permissible ambient temperature does not exceed 80 °C.

### 2.1 Installing the valve

The valve may be installed in any desired position, however, we recommend that the valve be installed in a horizontal pipeline with the thermostat vertically suspended. The medium must flow through the valve in direction indicated by the arrow on the valve body.

#### 2.1.1 Strainer

A strainer (SAMSON Type 1 NI) must be installed upstream of the relevant valve, since sealing particles, globules or other impurities carried along by the process medium could impair the proper functioning of the valve, especially tight shut-off. The filter element must be vertically suspended.

Ensure that ample space is available to remove the filter.

#### 2.1.2 Additional installation instructions

Ideally, hand-operated shut-off valves should be installed both upstream of the strainer and downstream of the regulator. This allows the plant to be shut down for cleaning and maintenance routines, or when the plant is not operated for extended periods.

To check the adjusted set point, we recommend that a thermometer be installed near the sensor immersed in the medium to be controlled.

### 2.2 Installing the temperature sensor

The temperature sensor may be installed in any desired position. Its entire length must be immersed in the medium to be controlled.

When choosing the point of installation, make sure that the sensor is installed in a lo-

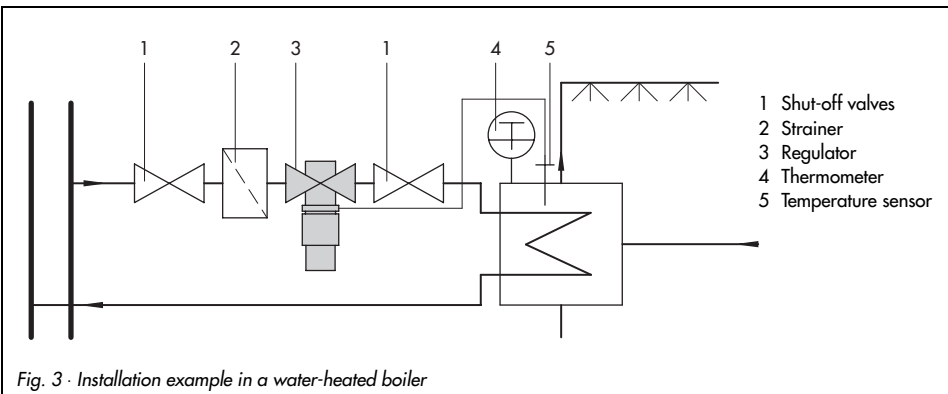

Fig. 3 - Installation example in a water-heated boiler

cation where overheating and considerable idling times do not occur.

A welding socket with a G 1/2 female thread connection should be welded where the sensor is to be installed.

- ▶ Seal the screw gland or thermowell into the welding socket.  
Insert the sensor and tighten it with the clamping screw.

### CAUTION!

*To prevent damage caused by corrosion, it is important to make sure on installing the sensor or thermowell that only the same kind of materials are used together. For example, do not use a sensor or thermowell made of non-ferrous metal in a stainless steel heat exchanger. In this case, the sensor should be used together with a stainless steel thermowell.*

## 2.2.1 Capillary tube

The capillary tube should be routed without bends or twists. The smallest bending radius is 50 mm. Roll up any extra length to form a ring. Do not bend or shorten.

The ambient temperature around the tube should be kept as even as possible.

## 3. Operation

### 3.1 Adjusting the set point

To adjust the set point value, use the black plastic ring (set point adjuster 8) while watching the reference thermometer.

The adjustment diagrams below can be used as a guide to find the first approximate value. The adjustment is infinitely variable. Turning the ring clockwise reduces the temperature and counterclockwise turning increases it. The temperature can be fixed at an adjusted value by lead-sealing the bore (14) in the set point adjuster.

Set point range °C	Set point change per turn	Sensor diameter
0 to 35	2.5	9.5
25 to 70	3	9.5
40 to 100	4	9.5

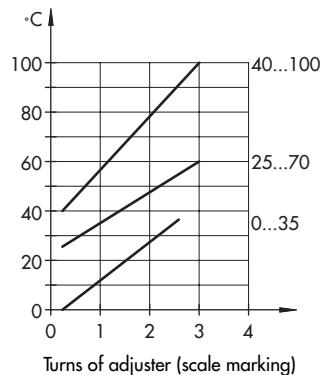

Fig. 4 · Set point adjustment

### 4. Troubleshooting

Should the temperature exceed the set point adjusted, the cause could be either contamination of seat and plug or wear and tear of the seat and plug no longer ensuring tight shut-off.

For remedy, the valve can be disassembled after shutting down the plant.

### 5. Customer inquiries

Should you have any inquiries regarding the temperature regulator, please submit the following details:

(see also nameplate)

- ▶ Type and nominal size
- ▶ Order no. and product no.
- ▶ Upstream and downstream pressure
- ▶ Type of process medium and temperature
- ▶ Max. and min. flow rate
- ▶ Has a strainer been installed?
- ▶ Installation drawing

## 6. Dimensions in mm

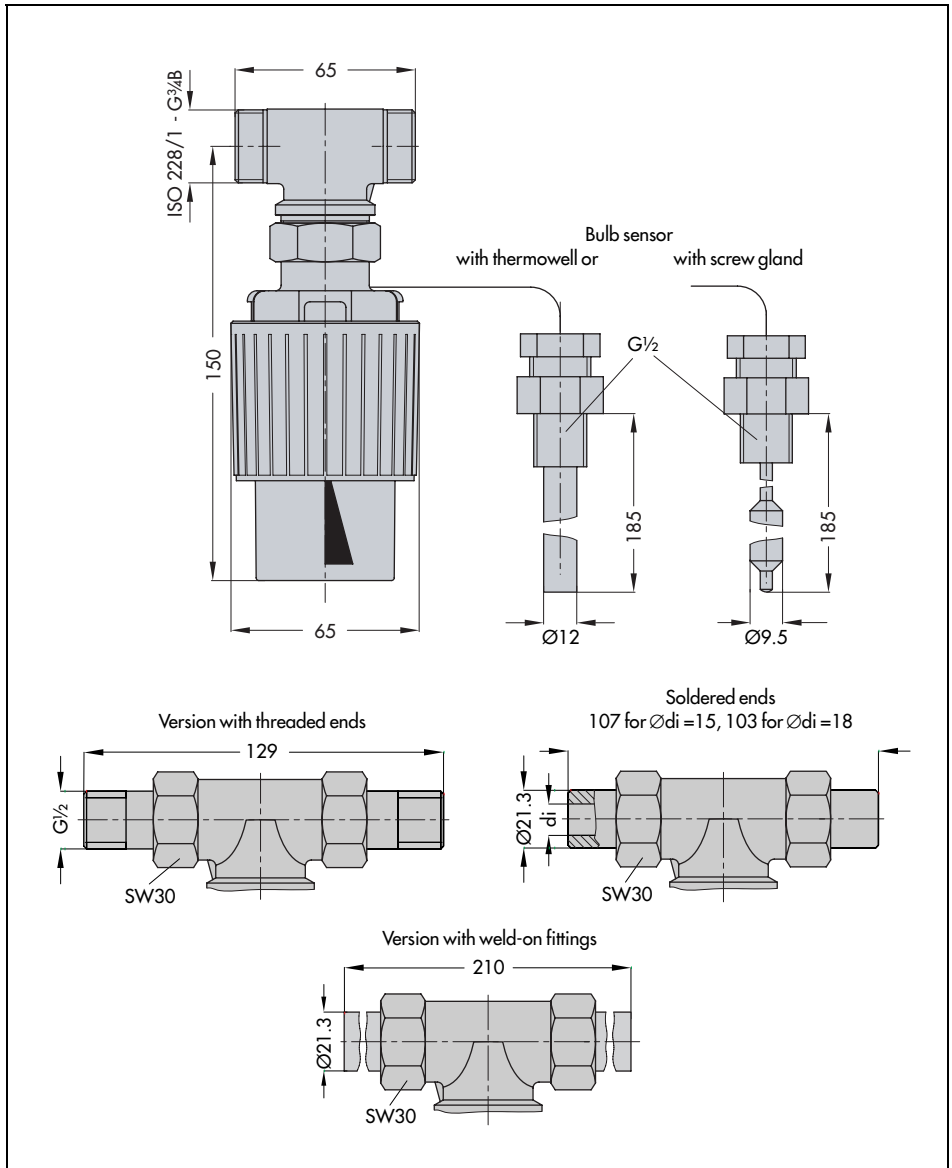



SAMSON AG · MESS- UND REGELTECHNIK  
Weismüllerstraße 3 · D-60314 Frankfurt am Main  
Telefon (0 69) 4 00 90 · Telefax (0 69) 4 00 95 07  
Internet: <http://www.samson.de>

**EB 2186 EN**

S/C 2001-07