

Safety Shut-off Valve with Pressure Reducer Type 33-1



Fig. 1 · Type 33-1

Mounting and Operating Instructions

EB 2551-1 EN

Edition June 1999

1. Design and principle of operation

The pressure reducer comprises a globe valve and an actuator with attached pilot valve.

The pressure reducer is designed for maintaining the pressure downstream of the valve at a set point value adjusted on the pilot valve.

The valve closes when the downstream pressure rises.

The medium flows through the valve as indicated by the arrow. The position of the valve plug and hence the free area between the plug (3) and seat (2) controls the downstream pressure p_2 .

The forces acting on the valve plug are balanced upstream and downstream by a balancing bellows (5).

The upstream pressure p_1 is supplied as auxiliary energy to the pilot valve via control line, causing the pilot valve to produce a control pressure p_s as a function of the set

point adjustment.

In controlling, the forces which are produced on both sides of the operating diaphragm (6) are compared. Here, the force of the control pressure p_s acts on one side of the diaphragm via the control line (12), and the force of the downstream pressure p_2 together with the force of the positioning springs (7) acts on the other side.

If, e.g., the downstream pressure p_2 to be controlled decreases, the control pressure p_s rises and the valve opens correspondingly.

If the downstream pressure p_2 equals the control pressure p_s , the valve is closed by the force of the positioning springs (7).

Important: For the valve to function properly, the minimum differential pressure Δp_{\min} must be in accordance with the values listed in the table.



Assembly, start-up and operation of the device may only be performed by trained and experienced personnel familiar with this product.

According to these Mounting and Operating Instructions, trained personnel is referred to persons who are able to judge the work they are assigned to and recognize possible dangers due to their specialized training, their knowledge and experience as well as their knowledge of the relevant standards.

Any hazards which could be caused by the process medium, the signal pressure and moving parts of the control valve must be prevented by means of appropriate measures.

Moreover, you are required to make sure the control valve is only used for applications where the operating pressure and temperatures do not exceed the operating values which are based on the valve sizing data submitted in the order.

Proper shipping and appropriate storage are assumed.

DN	65	80	100	125	150	200	250
p_{1max}	25 bar						
Δp_{min}	0.4 bar	0.5 bar		0.6 bar			
Δp_{max}	16 bar	12 bar	10 bar				

Typetesting:

The device has been typetested by the German Technical Inspectorate (TÜV) as a safety shut-off valve (SSV).

(Test marks are available on request)

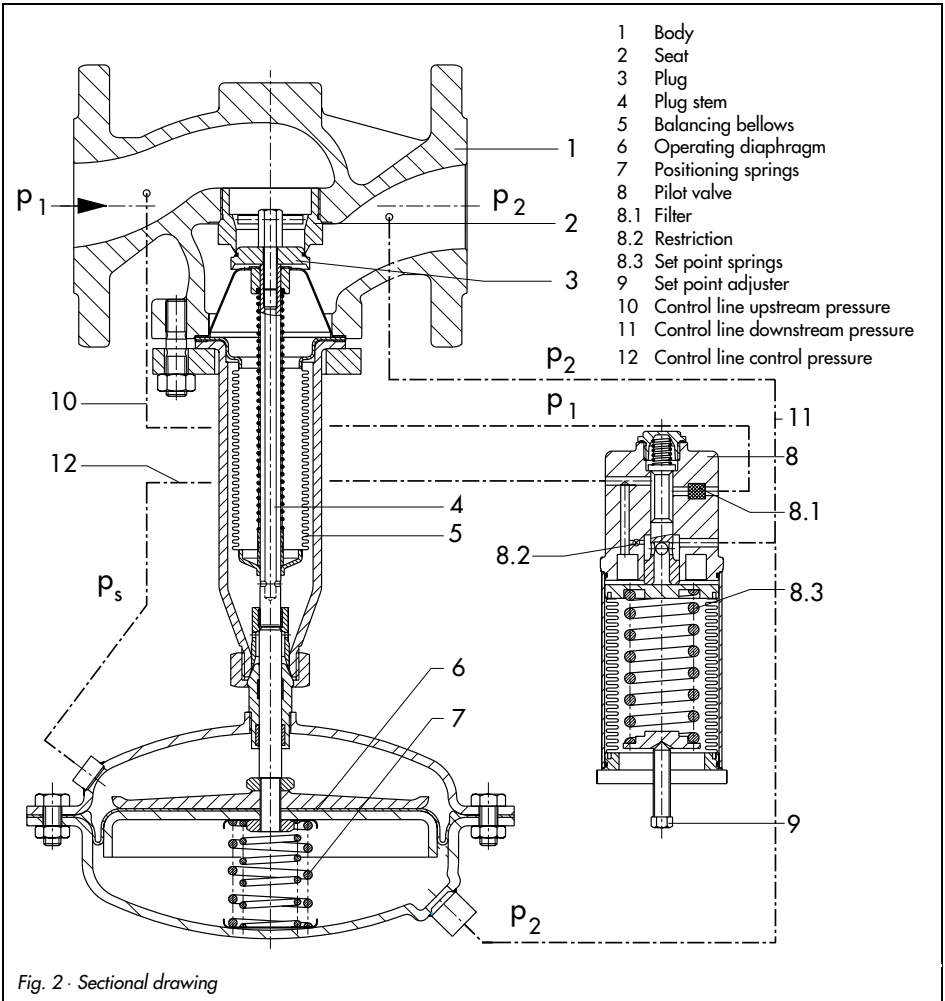

Fig. 2 · Sectional drawing

2. Installation

The pressure reducing valve must be installed in a horizontal pipeline with the actuator vertically suspended.

The direction of medium flow must be in accordance with the arrow on the body.

When selecting the location of installation, ensure that the regulator remains easily accessible after the plant has been installed.

Important!

The regulator must be installed free of stress. If necessary, support the piping near the connections. Do not, however, mount these supports on the valve or control line.

Before you install the regulator, thoroughly flush the pipeline, since sealing particles, globules or other impurities carried along by the process medium could impair the proper functioning of the valve, especially tight shut-off.

Important!

Always install a strainer (SAMSON Type 2 NI) upstream of the regulator.

2.1 Strainer

Install the strainer upstream of the pressure reducing valve. The direction of medium flow must be in accordance with the direction indicated by the arrow on the body. Make sure that the filter element is vertically suspended and that ample space is available to disassemble the filter.

2.2 Shut-off valves and pressure gauges

Ideally, hand-operated shut-off valves should be installed both upstream and downstream of the pressure regulator. This allows the plant to be shut down for cleaning or maintenance routines, or when the plant is not operated for extended periods. To observe the pressures prevailing in the plant, install a pressure gauge both upstream and downstream of the regulator.

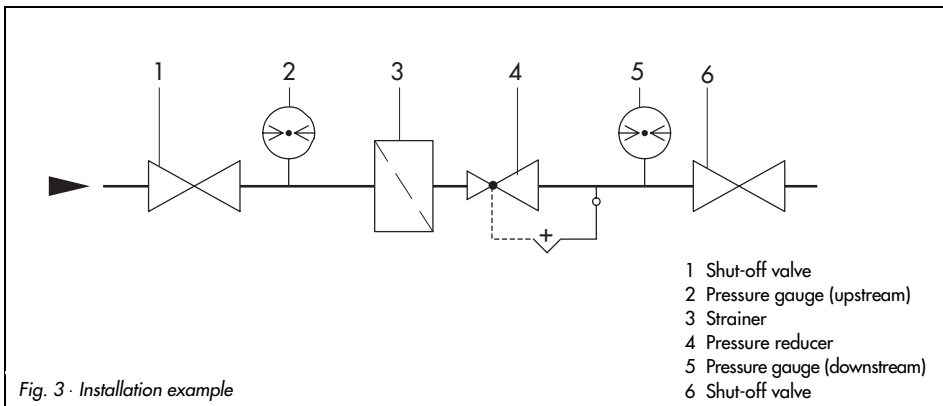

Fig. 3 · Installation example

3. Operation

3.1 Start-up

First open the shut-off valve downstream of the pressure reducing valve. Then slowly open shut-off valve upstream of the pressure reducing valve.

3.2 Set point adjustment

Adjust the required downstream pressure by turning the set point adjuster (9) on the pilot valve (8).

Turn clockwise to increase/counterclockwise to decrease the downstream pressure.

The pressure gauge on the downstream side enables operators to check the adjusted set point.

4. Troubleshooting

If the downstream pressure (pressure gauge downstream of the pressure regulator) deviates considerably from the adjusted set point, you should first check the passage of the control lines.

If necessary, remove and clean the filter (8.1) located in the inlet port of the pilot valve to which the control line is connected.



Prior to performing any type of installation work on the control valve, the respective part of the plant must be depressurized and drained by all means.

We recommend disassembling the device.

With other causes, such as an untight operating diaphragm (valve remains closed), or a damaged seat and plug, we recommend to contact our after sales service or return the device to the manufacturer for repair.

5. Dimensions in mm

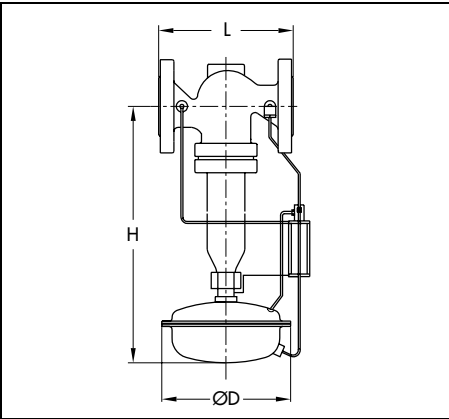

Nominal size	DN	65	80	100	125	150	200	250
Length	L	290	310	350	400	480	600	730
Height	H	605	605	635	685	815	925	925
Diaphragm case	ø D	380 (A = 640 cm ²)						
Weight for PN16 ¹⁾	kg	53	58	66	96	140	280	330

¹⁾ +10 % for steel and spheroidal graphite iron PN 25

6. Customer inquiries

Should you have any inquiries regarding the valve, please submit the following details: (see name plate)

- ▶ Type and nominal size
- ▶ Order no. and product no.
- ▶ Pressure upstream/downstream of the valve
- ▶ Flow rate in m³/h
- ▶ Has a strainer been installed?
- ▶ Installation drawing



SAMSON AG · MESS- UND REGELTECHNIK
Weismüllerstraße 3 · D-60314 Frankfurt am Main
Telefon (0 69) 4 00 90 · Telefax (0 69) 4 00 95 07
Internet: <http://www.samson.de>

EB 2551-1 EN

S/C 07.99

Conversion from chromate coating to iridescent passivation



Conversion from chromate coating to iridescent passivation

We at SAMSON are converting the surface treatment of passivated steel parts in our production. As a result, you may receive a device assembled from parts that have been subjected to different surface treatment methods. This means that the surfaces of some parts show different reflections. Parts can have an iridescent yellow or silver color. This has no effect on corrosion protection.

For further information, go to ► www.samson.de/chrome-en.html
