

Self-operated Pressure Regulators



Type 2335 Excess Pressure Valve with pilot valve



Type 2335 Excess Pressure Valve

Mounting and Operating Instructions

EB 2552-2 EN

Edition January 2016



Definition of signal words



DANGER!

Hazardous situations which, if not avoided, will result in death or serious injury



WARNING!

Hazardous situations which, if not avoided, could result in death or serious injury



NOTICE

Property damage message or malfunction



Note:

Additional information



Tip:

Recommended action

1	General safety instructions	4
2	Process medium and scope of application	5
2.1	Transportation and storage	5
3	Design and principle of operation	6
4	Installation	9
4.1	Notes on installation	9
4.2	Strainer (filter).....	10
4.3	Shut-off valve.....	11
4.4	Pressure gauge	11
5	Operation	12
5.1	Start-up.....	12
5.2	Steam applications.....	12
5.3	Set point adjustment.....	12
5.4	Decommissioning	13
6	Maintenance	14
7	Nameplate	19
8	Technical data	21
9	Dimensions	23
10	Customer service	25



1 General safety instructions

- The device must be mounted, started up or serviced by fully trained and qualified personnel only; the accepted industry codes and practices are to be observed. Make sure employees or third persons are not exposed to any danger.
- All safety instructions and warnings given in these mounting and operating instructions, particularly those concerning installation, start-up and maintenance, must be strictly observed.
- According to these mounting and operating instructions, trained personnel refers to individuals who are able to judge the work they are assigned to and recognize possible dangers due to their specialized training, their knowledge and experience as well as their knowledge of the applicable standards.
- The regulator complies with the requirements of the European Pressure Equipment Directive 97/23/EC. The declaration of conformity issued for a regulator bearing the CE marking includes information on the applied conformity assessment procedure. This declaration of conformity can be provided on request.
- To ensure appropriate use, only use the regulator in applications where the operating pressure and temperatures do not exceed the specifications used for sizing the regulator at the ordering stage.
- The manufacturer does not assume any responsibility for damage caused by external forces or any other external factors.
- Any hazards that could be caused in the valve by the process medium, operating pressure or by moving parts are to be prevented by taking appropriate precautions.
- Proper transport, storage, installation, operation and maintenance are assumed.

2 Process medium and scope of application

Pressure regulators for set points from 2 to 28 bar · Valve nominal sizes DN 125 to 400 · Nominal pressure PN 16 to 40 · Suitable for liquids, gases and vapors up to 350 °C

The differential pressure across the regulator is used as auxiliary energy to operate the valve. To open the regulator, this pressure must be at least as high as the minimum differential pressure Δp_{\min} specified in Table 1.

The mounted pilot valve (excess pressure valve) determines the function of the regulator.

**WARNING!**

Risk of uncontrolled excess pressure in the plant.

Risk of bursting

If necessary, a suitable overpressure protection must be installed on site in the plant section.

2.1 Transportation and storage

The regulator must be carefully handled, transported and stored. Protect the regulator against adverse influences, such as dirt, moisture or temperature outside the ambient temperature range.

Do not remove the protective caps from the valve ports until immediately before installing the valve into the pipeline.

When regulators are too heavy to be lifted by hand, fasten the lifting sling at a suitable place on the valve body.

**WARNING!**

Do not attach lifting slings or supports to mounting parts, such as control line, pilot valve etc.

The valve can fall or mounting parts may be damaged.

Securely fasten slings or supports to the valve body and secure against slipping.

3 Design and principle of operation

See Fig. 1 on page 7 and Fig. 2 on page 8.

The medium flows through the globe valve (1) in the direction indicated by the arrow. The position of the plug determines the flow rate across the area released between plug (3) and valve seat (2). The travel of the pilot valve (5) determines the pressure conditions across the valve.

The forces created by the upstream pressure p_1 acting on the plug surface and by the control pressure p_s acting on the balancing bellows (4) or balancing diaphragm (11) and the force of positioning spring (3.1) are compared.

In the Type 2335 Excess Pressure Valve, the rising upstream pressure p_1 causes the main valve to open. Together with the pilot valve, the Venturi nozzle (8) (the fixed restriction (6) and needle valve (9) in the version for steam) create the control pressure p_s .

When the pilot valve is closed, the valve to be fully balanced. The control pressure p_s between the pilot valve and Venturi nozzle acting on the outside of the balancing bellows (4) or balancing diaphragm (4) and the upstream pressure p_1 balance each other out ($p_s = p_1$). The positioning spring below the valve plug closes the valve.

When the pilot valve opens, the control pressure p_s falls, causing the differential pressure at the balancing bellows or balancing diaphragm to increase. The force acting on the plug surface opposes the force of the positioning springs and the valve opens.

To ensure proper functioning, the minimum differential pressure Δp_{\min} must be available as specified depending on the field of application.

The regulator version for **steam** is only available with valves balanced by a bellows. This version has a condensation chamber (10) already fitted in the control line. The needle valve (9) is open and lead-sealed.

Before start-up, fill the condensation chamber with water at the top filler opening.

Table 1: Minimum differential pressure Δp_{\min}

Nominal size		DN 125	DN 150	DN 200	DN 250	DN 300	DN 400
Minimum differential pressure Δp_{\min}	Valve balanced by a bellows for steam applications	1.9 bar	2.0 bar	1.4 bar	1.4 bar	–	–
	Valve balanced by a bellows for air/water	1.0 bar	1.0 bar	0.7 bar	0.7 bar	–	–
	Valve balanced by a diaphragm	0.8 bar	0.8 bar	0.4 bar	0.4 bar	0.5 bar	0.3 bar

Type 2335 Excess Pressure Valve · Type 2422 Valve balanced by a bellows · DN 125 to 250

Type 2422 as main valve balanced by a bellows

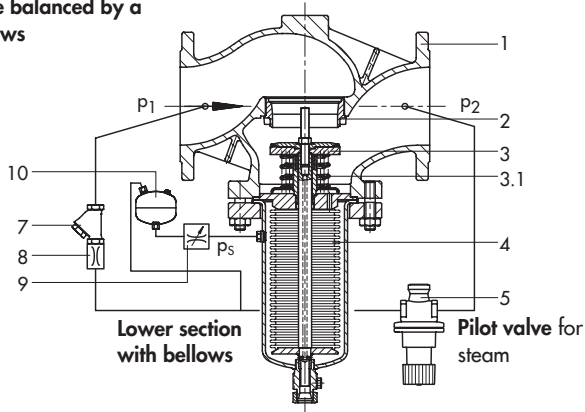

Version suitable for vapors

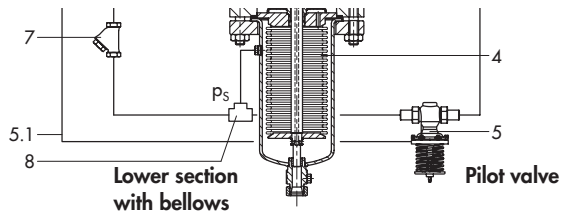

Version suitable for liquids and gases

- | | | | |
|-----|--|-------|---|
| 1 | Globe valve (main valve) | 8 | Fixed restriction (version for steam) |
| 2 | Valve seat | 9 | Needle valve (version for steam) |
| 3 | Plug with plug stem | 10 | Condensation chamber (only for steam or medium temperatures above 150 °C) |
| 3.1 | Positioning spring | p_s | Control pressure |
| 4 | Balancing bellows | p_1 | Upstream pressure |
| 5 | Pilot valve | p_2 | Downstream pressure |
| 6 | Venturi nozzle (for gases and liquids) | | |
| 7 | Strainer | | |

Fig. 1: Functional diagram of valve balanced by a bellows

Type 2335 Excess Pressure Valve · Type 2422 Valve, **balanced by a diaphragm** · DN 125 to 400

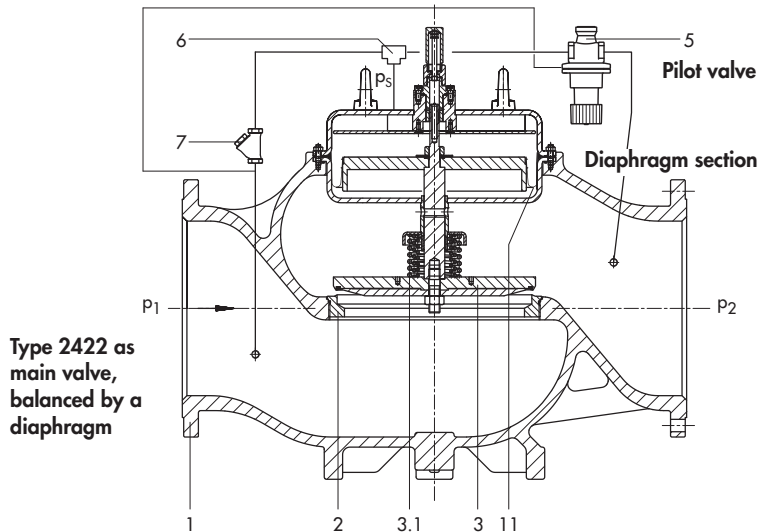

- | | | | |
|-----|-------------------------|-------|---------------------|
| 1 | Valve body (main valve) | p_s | Control pressure |
| 2 | Valve seat | p_1 | Upstream pressure |
| 3 | Plug with plug stem | p_2 | Downstream pressure |
| 3.1 | Positioning spring | | |
| 5 | Pilot valve | | |
| 6 | Venturi nozzle | | |
| 7 | Strainer | | |
| 11 | Balancing diaphragm | | |

Fig. 2: Functional diagram of valve balanced by a diaphragm

4 Installation

See Fig. 3 on page 10.

Select the installation location making sure that the regulator is installed at a distance of at least six times the nominal size (DN) away from pipe fittings or instruments that cause flow turbulence (e.g. pipe bends, manifolds, pressure measuring points or other valves). They can change the flow conditions which may lead to an instable control process especially in applications with gases, air or steam. Contact SAMSON to obtain the TV-SK 17041 documentation which contains more details on installation requirements.

4.1 Notes on installation

Install the ready-assembled regulator in horizontal pipelines.

- Flush and clean the pipeline thoroughly before installing the regulator. Otherwise, impurities in the pipeline may impair the proper functioning of the valve, above all the tight shut-off.
- Direction of flow must match the direction indicated by the arrow on the body.
- Install the regulator free of stress. If necessary, support the pipeline near to the connecting flanges. Do not attach supports directly to the valve or actuator.
- Install a strainer upstream of the regulator.
- Protect the regulator from icing up when controlling media that can freeze. If necessary, depressurize and drain the reg-

ulator and remove it from the pipeline while the plant is shut down.



Note:

The side on which the operating elements (hook-up of the pilot valve) are located varies depending on whether a valve balanced by a bellows or a diaphragm is used.

Mounting position

Install the regulators in horizontal pipelines. Observe the flow direction.

Valve balanced by a bellows

Bellows including housing suspended downward



Valve balanced by a diaphragm

- Balancing diaphragm (diaphragm section) pointing upward

Insulation · To insulate cold systems, we recommend first filling the plant and carefully rinsing it (see section 5.1). The regulator must not be insulated until the set point is adjusted.

- Start up the plant and adjust the set point. Shut down the plant again and let it warm up until the condensation water has dried off.
- Afterwards, insulate the regulator and pipes conveying the process medium using insulation material with a water vapor barrier. If the pilot valve has a spring, it must be protected by a sleeve to allow it to move. The

spring-loaded actuator stem must not touch the insulation.

Thermal insulation



Note:

Do not insulate the pilot valve as well in applications with medium temperatures above 80 °C.

- The filter element must be installed to hang downwards or sideways for applications with steam.



Tip:

Remember to leave enough space to remove the filter element.

Pressure testing of the plant · The pressure must not exceed the maximum permissible pressure of the regulator and plant on testing the pressure of the plant when the regulator is already installed. An excessive test pressure can damage the balancing bellows or diaphragm. If necessary, remove the regulator from the pipeline or isolate the regulator in the pipeline and install a bypass.

4.2 Strainer

Install a strainer (e.g. SAMSON Type 1/ Type 2) upstream of the excess pressure valve.

- The direction of flow must correspond to the arrow on the body.

4.3 Shut-off valve

Install a hand-operated shut-off valve both upstream of the strainer and downstream of the regulator. This allows the plant to be shut down for cleaning and maintenance, and when the plant is not used for longer periods of time.

4.4 Pressure gauge

Install a pressure gauge both upstream and downstream of the regulator to monitor the pressures prevailing in the plant.

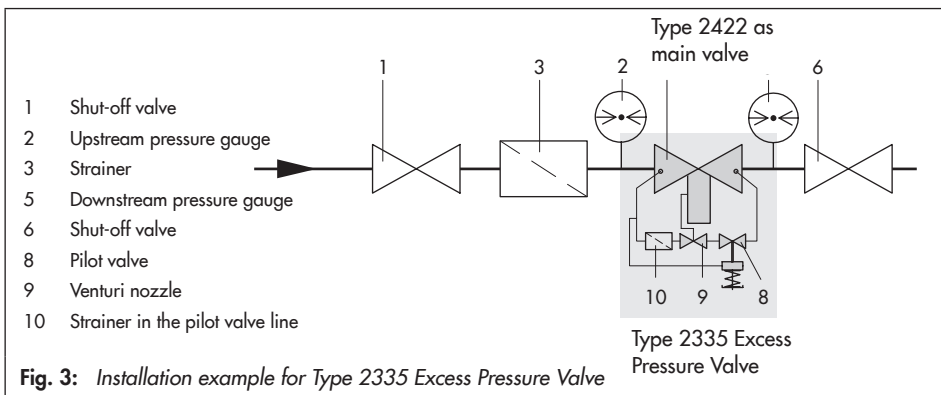

Fig. 3: Installation example for Type 2335 Excess Pressure Valve

5 Operation

See Fig. 1 on page 7 and Fig. 2 on page 8.

5.1 Start-up

First start up the regulator after mounting all parts (e.g. valve and control line). Open control line with needle valve and check to ensure it is connected correctly.

Rinsing the plant · After filling the plant, first completely open the consumer and adjust the regulators to achieve the maximum flow rate. Rinse out the pipeline at full flow rate for several minutes. Check the installed strainer (e.g. by measuring the pressure drop). Clean the strainer, if necessary.

- Slowly fill the plant. Make sure that the pressure rises simultaneously upstream and downstream of the regulator to avoid damaging the balancing bellows/diaphragm.
- Open all the valves on the consumer side. Slowly open the shut-off valves starting on the flow pipe side in small steps waiting a few minutes in between.

5.2 Steam applications

Observe the following points for applications with steam:

- Before start-up, all pipes conveying the process medium must be completely drained and dry (to prevent steam hammering).

- Before start-up, fill the condensation chamber (10) with water (also at the pilot valve, if necessary).
- Slowly start up the plant and allow time for the pipes and valves to warm up.
- Air and condensate must be allowed to escape from the plant.

Install steam trap (e.g. SAMSON Type 13 E) or air vent for steam-operated systems (e.g. SAMSON Type 3) at a suitable location.

5.3 Set point adjustment

Adjust the required pressure set point while the plant (consumer) is open by turning the set point adjuster at the pilot valve (5).

When the adjusted upstream pressure (set point) is reached, the pilot valve opens, causing the main valve to open as well.

Turn clockwise (↻):

- To increase the pressure set point

Turn counterclockwise (↺):

- To reduce the pressure set point

The pressure gauge located on the upstream pressure side allows the adjusted set point to be monitored.

First set the maximum set point by turning the set point adjuster clockwise (↻).

Wait until the excess pressure valve starts to regulate before adjusting the set point by slowly turning the adjuster counterclockwise (↺).

! NOTICE

Incorrectly adjusted set point or set point cannot be adjusted.

Malfunction

Start by turning the set point adjuster by one turn at a time and wait until the upstream pressure reaches the set point. As soon as the excess pressure valve starts to work, you can adjust the set point by making larger changes. Wait several minutes until the pressure conditions have stabilized and check the set point. Correct the set point, if necessary.

After start-up and set point adjustment, avoid fast changes in pressure.

5.4 Decommissioning

Depressurize the plant. Close the shut-off valves starting from the flow side (high-pressure line).

6 Maintenance

See Fig. 1 on page 7 and Fig. 2 on page 8.

The regulator does not require any maintenance. Nevertheless, it is subject to natural wear, particularly at the seat, plug and operating diaphragm.

Depending on the operating conditions, check the regulator at regular intervals to avoid possible malfunctions.



WARNING!

Performing work on pressurized or hot plant sections!

Hot process medium can escape uncontrolled on dismantling the regulator. Risk of scalding!

Allow the regulator to cool down before depressurizing and draining it and remove it from the pipeline!

Details on faults and how to remedy them can be found in Table 2 on page 14.

The listed examples of malfunctions are caused by mechanical faults in the main valve or pilot valve as well as incorrect regulator sizing.

In the simplest case, the functioning can be restored following the recommended action. To repair the pilot valve, read the operating instructions for the corresponding regulator (pilot valve). As in many cases, special tools are required, we advise you to contact SAMSON after-sales service to find out how to proceed to repair the regulator or replace a component (see section 10 on page 22).

Exceptional operating and installation conditions can lead to changed situations that may affect the control response and lead to malfunctions. In such cases, check the installation conditions, process medium, temperature and pressure conditions. A thorough analysis may often require the on-site assistance of SAMSON after-sales service.

The table is not intended to be exhaustive as there are diverse reasons for malfunctions.

Table 2: Troubleshooting

Malfunction	Possible reasons	Recommended action	Note
Upstream pressure does not reach the adjusted pressure set point	Malfunction only occurs when the consumer is closed or during low load:		
	Pilot valve · Leakage between seat and plug	Remove valve from the pipeline and clean seat and plug. Renew plug, if necessary. If this is not possible, return regulator to SAMSON for repair.	Install a shut-off valve instead of the pilot valve. If the main valve closes when the shut-off valve is closed, the pilot valve has caused the malfunction.
	Main valve · Leakage between seat and plug	Remove valve from the pipeline and clean seat and plug. Renew plug, if necessary. If this is not possible, return regulator to SAMSON for repair.	
	Balancing bellows/diaphragm of the main valve defective.	Replace bellows/diaphragm.	Install a shut-off valve instead of the pilot valve. If the main valve does not open when the shut-off valve is opened, the main valve has caused the malfunction. Particularly in steam applications, steam hammering can damage the bellows. Therefore, make sure that no water or condensate is present in the pipeline before start-up.
Upstream pressure is much higher than the adjusted pressure set point	Malfunction occurs when the consumer is open or at maximum load:		
	The pilot valve does not function. Balancing bellows/diaphragm defective. Medium leaks from the actuator.	Replace the defective component.	Install a shut-off valve instead of the pilot valve. If the main valve opens when the shut-off valve is opened, the pilot valve has caused the malfunction.
	Pilot valve seized up	Clean the pilot valve. Apply grease to plug stem guides, if necessary. Replace defective parts.	
	Main valve seized up	Clean main valve.	Install a shut-off valve instead of the pilot valve. If the main valve does not open when the shut-off valve is opened, the main valve has caused the malfunction.
	In steam applications: plant started up too quickly.	Fill condensation chambers with water. Slowly start up the plant.	

Troubleshooting (continued)

Malfunction	Possible reasons	Recommended action	Note
The pressure does not reach the set point.	Strainer in the line in which the pilot valve is installed is clogged up	Clean strainer.	
	The required minimum differential pressure to operate the regulator is not available	Raise upstream pressure or reduce downstream pressure	
	Set point range of the pilot valve is too low	Convert or replace pilot valve.	
	Main valve seized up	Clean main valve.	Install a shut-off valve instead of the pilot valve. If the main valve does not open when the shut-off valve is opened, the main valve has caused the malfunction.
	Pilot valve seized up	Clean pilot valve. Clean internal control line used to tap the upstream pressure.	
	Needle valve (steam) installed between fixed restriction and main valve is blocked or closed.	Clean the needle valve. Check setting (open).	
	Main valve is sized to be too small (K_{VS}/C_V)	Resize the valve. Replace main valve.	
Regulator's reaction is sluggish	Strainer in the line in which the pilot valve is installed is clogged up.	Clean strainer.	
	Inside the pilot valve is clogged up, impairing the flow through the valve	Clean inside the pilot valve.	
	Needle valve (steam) installed between fixed restriction and main valve is blocked.	Clean the needle valve. Check setting (open).	
	The fixed restriction is clogged up.	Clean fixed restriction.	
	Control line or Venturi nozzle blocked	Clean parts.	Improve steam conditioning, if necessary.

Troubleshooting (continued)

Malfunction	Possible reasons	Recommended action	Note
Control loop hunts	K_{VS}/C_V of pilot valve too large (after valve has been replaced).	Install pilot valve with suitable K_{VS}/C_V coefficient.	
	The flow conditions in the plant at the location where the regulator is installed are not suitable for the regulator.	Pipe reducers, instruments and diversions can change the flow conditions which may lead to an instable control process especially in applications with gases, air or steam. Refer to the SAMSON document TV-SK 17041 for minimum distances.	If this is the case, send a sketch of the plant to SAMSON for a thorough analysis.
	K_{VS}/C_V of main valve too large	Resize the valve. Replace main valve or reduced the flow rate (smaller K_{VS}/C_V coefficient).	
	Occasional vibrational excitation originating from the plant	Contact SAMSON.	Possibly change the natural frequency, e.g. over the needle valve (9) when there is resonance in the plant.

7 Nameplate

Nameplate of main valve

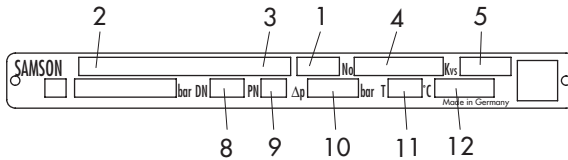

DIN version

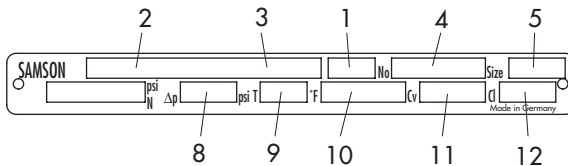

ANSI version

Valve

- 1 Valve type
- 2 Model number
- 3 Model number index
- 4 Order number or date
- 5 K_{VS} coefficient
- 8 Nominal size
- 9 Nominal pressure
- 10 Perm. differential pressure in bar
- 11 Perm. temperature in °C
- 12 Body material

For ANSI version

- 5 Nominal size
- 8 Perm. differential pressure in psi
- 9 Perm. temperature in °F
- 10 Body material
- 11 C_V coefficient ($K_{VS} \times 1.17$)
- 12 ANSI Class (pressure rating)

Fig. 4: Nameplate of Type 2335 Excess Pressure Valve

8 Technical data

Table 3: Technical data · All pressures in bar (gauge)
Type 2422 Valve · Balanced by a bellows · Suitable for liquids, gases or vapors

Nominal size	DN 125	DN 150	DN 200	DN 250
Nominal pressure	PN 16 to 40			
Standard K_{VS} coefficients				
K_{VS} coefficient	200	360	520	620
K_{VS} I (with flow divider St I)	150	270	400	500
K_{VS} III (with flow divider St III)	100	180	260	310
Minimum differential pressure Δp_{\min}				
Version for water	1.0 bar	1.0 bar	0.7 bar	0.7 bar
Version for steam	1.9 bar	2.0 bar	1.4 bar	1.4 bar
Max. permissible differential pressure Δp_{\max}	16 bar	12 bar	10 bar	10 bar
Reduced K_{VS} coefficients (only for valves balanced by a bellows)				
K_{VS} coefficient	80	125	360	360
K_{VS} I (with flow divider St I)	60	95	270	270
K_{VS} III (with flow divider St III)	40	60	180	180
Minimum differential pressure Δp_{\min}				
Version for water/air	0.2 bar ¹⁾	0.2 bar ¹⁾	1.0 bar	1.0 bar
Version for steam	–	–	1.9 bar	1.9 bar
Max. perm. differential pressure Δp_{\max}	20 bar	16 bar	12 bar	12 bar
x_{FZ} value	0.35	0.3	0.3	0.3
Leakage class according to IEC 60534-4	$\leq 0.05\%$ of K_{VS} coefficient ²⁾			
Compliance	CE · EAC			
Max. permissible temperature Depending on the pilot valve	Type 44-7: 150 °C · Type 44-6 B: 150 °C ³⁾ Type 2406: 150 °C · Type 41-73: 150 °C ⁴⁾			
Set point ranges in bar Continuously adjustable at the pilot valve	Type 44-7: 2 to 4.4, 2.4 to 6.6, 6 to 11 Type 44-6 B: 2 to 6, 4 to 10, 8 to 20 Type 2406: 2 to 5, 4.5 to 10 · Type 41-73: 2 to 5, 4.5 to 10, 8 to 16, 10 to 22, 20 to 28			

¹⁾ With Type 2420 Diaphragm Actuator, 640 cm²
²⁾ $\leq 0.1\%$ of K_{VS} coefficient with metal-seated plug

³⁾ Version for steam up to 200 °C

⁴⁾ Version for steam up to 350 °C

Type 2422 Valve · Balanced by a diaphragm · Suitable for liquids and gases

Nominal size	DN 125	DN 150	DN 200	DN 250	DN 300	DN 400
Nominal pressure	PN 16 to 40					
K_{VS} coefficient	250	380	650 ¹⁾	800 ¹⁾	1250	2000
x_{FZ} value	0.35	0.35	0.3 ¹⁾	0.3 ¹⁾	0.2	0.2
Minimum differential pressure Δp_{min}	0.8 bar	0.8 bar	0.4 bar ¹⁾	0.4 bar ¹⁾	0.5 bar	0.3 bar
Max. permissible differential pressure Δp_{max}	12 bar	12 bar	10 bar ¹⁾	10 bar ¹⁾	10 bar ¹⁾	6 bar
Leakage class according to IEC 60534-4	≤ 0.01 % of K_{VS} coefficient					
Compliance	CE · ENEC					
Max. permissible temperature Depending on the pilot valve	Type 44-7: 150 °C · Type 44-6 B: 150 °C · Type 2406: 150 °C · Type 41-73: 150 °C · Steam pressure regulator as special version on request					
Set point ranges in bar Continuously adjustable at the pilot valve	Type 44-7: 2 to 4.4, 2.4 to 6.6, 6 to 11 · Type 44-6 B: 2 to 6, 4 to 10, 8 to 20 · Type 2406: 2 to 5, 4.5 to 10 · Type 41-73: 2 to 5, 4.5 to 10, 8 to 16, 10 to 22, 20 to 28					

¹⁾ Version with reduced K_{VS} coefficient possible. Same technical data as DN 150

9 Dimensions

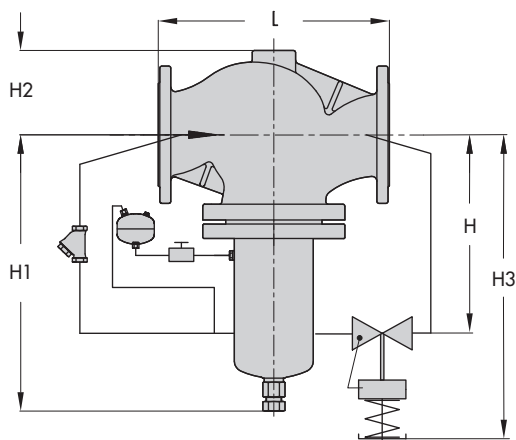

Type 2422 Valve · DN 125 to 250 · Balanced by a bellows

Nominal size	DN 125	DN 150	DN 200	DN 250
Length L	400 mm	480 mm	600 mm	730 mm
Height H	285 mm	315 mm	390 mm	390 mm
Height H1	460 mm	590 mm	730 mm	730 mm
Height H2	145 mm	175 mm	235 mm	260 mm
Max. height H3 ²⁾	≤ 725 mm	≤ 825 mm	≤ 890 mm	≤ 890 mm
Weight ¹⁾ (PN 16 with Type 44-6 B Pilot Valve)	75 kg	118 kg	260 kg	305 kg

¹⁾ +10 % for cast iron 1.0619/PN 25 and spheroidal graphite iron EN-JS1049/PN 25

²⁾ Depending on the pilot valve used

Fig. 5: Dimensions and weights · Type 2422 Valve *balanced by a bellows*

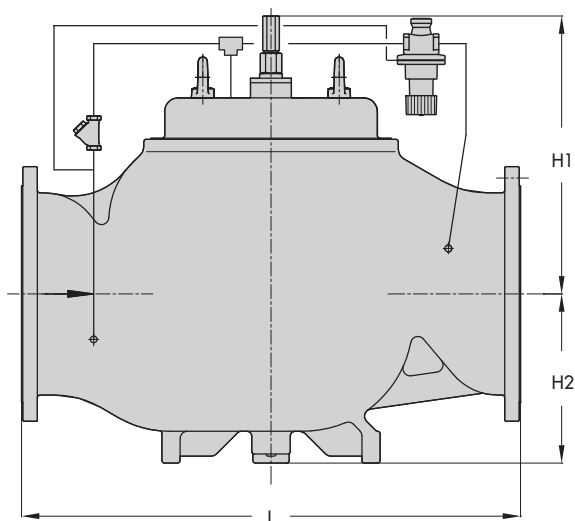

Type 2422 Valve · DN 125 to 400 · Balanced by a diaphragm

Nominal size	DN 125	DN 150	DN 200	DN 250	DN 300	DN 400
Length L	400 mm	480 mm	600 mm	730 mm	850 mm	1110 mm
Height H1	285 mm	310 mm	380 mm	380 mm	510 mm	610 mm
Height H2	145 mm	175 mm	260 mm	260 mm	290 mm	390 mm
Weight ¹⁾ (PN 16 with Type 44-6 B Pilot Valve)	50 kg	70 kg	210 kg	305 kg	315 kg	625 kg

¹⁾ +10 % for cast iron 1.0619/PN 25 and spheroidal graphite iron EN-JS1049/PN 25

Fig. 6: Dimensions and weights · Type 2422 Valve *balanced by a diaphragm*

10 Customer service

If malfunctions or defects occur, contact the SAMSON After-sales Service Department for support.

The addresses of SAMSON AG, its subsidiaries, representatives and service facilities worldwide can be found on the SAMSON website (► www.samson.de), in all SAMSON product catalogs or on the back of these Mounting and Operating Instructions.

Please send your inquiries to: service@samson.de

To assist diagnosis, specify the following details (see section 7):

- Type and nominal size of the valve
- Order and model number
- Order number or date
- Upstream and downstream pressure
- Temperature and process medium
- Min. and max. flow rate in m³/h
- Is a strainer installed?
- Installation drawing showing the exact location of the regulator and all the additionally installed components (shut-off valves, pressure gauge, etc.)
- Photo of the installed regulator, if possible



Note:

Conversion from chromate coating to iridescent passivation

We at SAMSON are converting the surface treatment of passivated steel parts in our production. As a result, you may receive a device assembled from parts that have been subjected to different surface treatment methods. This means that the surfaces of some parts show different reflections. Parts can have an iridescent yellow or silver color. This has no effect on corrosion protection.

For further information go to ► www.samson.de/chrome-en.html



SAMSON AG · MESS- UND REGELTECHNIK
Weismüllerstraße 3 · 60314 Frankfurt am Main, Germany
Phone: +49 69 4009-0 · Fax: +49 69 4009-1507
samson@samson.de · www.samson.de

EB 2552-2 EN

2016-03-11 · English