

### 1. Design and principle of operation

The excess pressure valve consists of a balanced control valve and a closing actuator equipped with springs and an operating diaphragm. A pilot valve with a strainer, needle valve and condensation chambers is attached to the excess pressure valve.

The excess pressure valve is designed to maintain the pressure upstream of the valve to a set point adjusted on the pilot valve.

The valve opens when the upstream pressure rises.

The medium flows through the free area between the seat (2) and the plug (3) in the direction indicated by the arrow. The plug position determines the upstream pressure (excess pressure) to be controlled.

In order to achieve this excess pressure as required, different forces are compared. These are produced by the upstream pressure  $p_1$  acting on the top surface of the diaphragm (7), by the control pressure  $p_s$  (determined by the pilot valve and the needle valve) acting on the bottom surface of the diaphragm and by the actuator springs (8).

When the upstream pressure ( $p_1$ ) rises, the pilot valve (10) opens further and this causes the differential pressure ( $p_1 - p_s$ ) to rise at the operating diaphragm. The actuator and plug stem move in the opening direction against the force of the actuator springs (8) until a new pressure equilibrium is reached and the upstream pressure ( $p_1$ ) corresponds again to the set point adjusted.

If the upstream pressure starts to decrease, the process described above is reversed. The pilot valve closes further, causing the differential pressure ( $p_1 - p_s$ ) to decrease again and

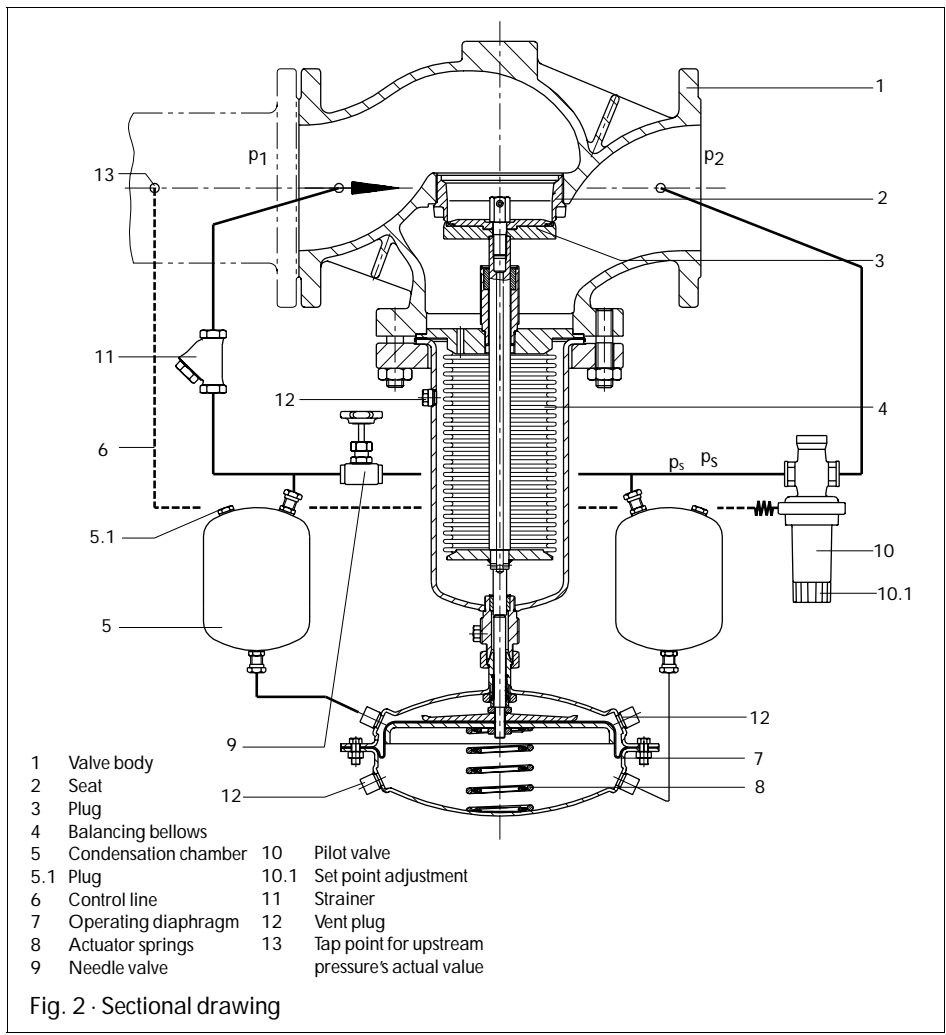

Fig. 2 · Sectional drawing

the actuator spring force has more effect. The valve plug also moves in the closing direction until the set point is reached.

## 2. Installation

### 2.1 Installation of the excess pressure valve

The excess pressure valve with the attached pilot valve, strainer and condensation chambers must be installed into a horizontal pipeline and with the actuator suspended downwards. The direction of the medium flow must coincide with the arrow on the valve body.

When selecting the location of installation, ensure that the regulator remains easily accessible after the plant has been installed.

Do not put excessive stress on the valve body when installing it into the plant. If necessary, support the piping near the valve flanges. **Do not, however, mount any supports on the valve, actuator or control line.**

The pipeline should be laid both sides of the valve with a slight slope in order to allow any condensation forming to drain off. If the piping upstream and downstream of the valve is laid vertically, a steam trap (SAMSON Type 13E Steam Trap) must be fitted.

**Do not install under any circumstances any devices which restrict the piping's cross-section (e.g. temperature regulator or shut-off valve) between the pressure tap point for the control line and the control valve.**

If a bypass has been equipped, its inlet must be upstream of the pressure tap point. A shut-off valve must be installed in the bypass pipe. Before installing the regulator, flush out thoroughly the pipeline, in order to ensure that any sealing parts, globules and other impurities carried along by the medium cannot impair the proper functioning of the valve, especially the tight shut-off. Always install a strainer (SAMSON Type 2) upstream of the excess pressure valve (see section 2.2).

#### 2.1.1 Control line

When the excess pressure valve is equipped with the Type 44-6 Pilot Valve, a control line (to be provided by the customer) with a 6 mm pipe diameter must be installed and when equipped with the Type 41-73 Pilot Valve with a 3/8" pipe.

Connect the control line at least 1 metre or 20 x DN away from the valve for tapping the upstream pressure in the pipeline.

Weld the control line onto the side of the pipeline and in the middle. Run the vertical part of the control line with an approx. 1:10 slope down towards the pilot valve.

Depending on the set point range, the Type 41-73 Pilot Valve can be equipped with a diaphragm actuator. In this case, an additional condensation chamber must be installed.

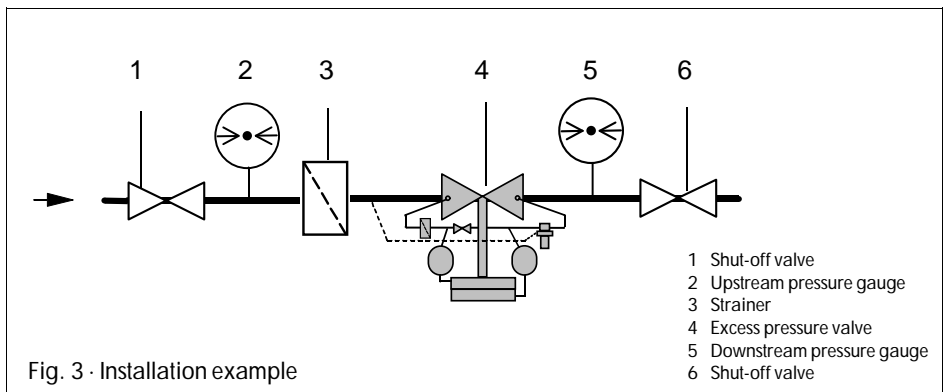

## 2.2 Strainer

Install the strainer upstream of the excess pressure valve. The direction of medium flow must correspond with the arrow on the body. Make sure the filter element is vertically suspended and that there is sufficient space available to remove the filter.

## 2.2 Shut-off valves and pressure gauges

We recommend the installation of hand-operated shut-off valves both upstream of the strainer and downstream of the valve. This allows the plant to be isolated for cleaning and maintenance purposes or when left unused for extended periods.

Install a pressure gauge both upstream and downstream of the regulator in order to be able to observe the pressures prevailing in the plant.

## 3. Operation

### 3.1 Start-up

**The condensation chambers must be filled with water before starting up the plant.**

In order to do this, remove the plugs (5.1) on the condensation chambers.

Pour in water using a funnel until the water starts to overflow. Then loosen the vent plugs (12) at the top and bottom of the actuator and screw them tight again when the water starts to leak out of the vent holes. Pour water again into the condensation chambers until it starts to overflow and then screw tight again the plugs (5.1).

Make sure the needle valve (9) is not closed. It has been opened 2 revolutions by the manufacturer.

Take the regulator into operation by slowly opening the shut-off valve upstream of the valve. Then slowly open the shut-off valve downstream of the valve.

This must be carried out carefully in order to prevent any condensation hammering.

## 3.2 Set point adjustment

Adjust the upstream pressure required by turning the set point adjustment (8.1) on the pilot valve (8).

Turn it clockwise to increase the upstream pressure and anti-clockwise to reduce the pressure. The set point adjusted can be checked by reading the upstream pressure gauge.

## 4. Faults

If the upstream pressure (see the pressure gauge upstream of the valve) deviates considerably from the set point adjusted, first check the passage of the control lines, then the associated needle valve and the strainer.

When faults occur due to other reasons, such as an untight operating diaphragm, or damaged seat and plug, we recommend you to contact our after sales service or to return the valve to the manufacturer for repair.

If the performance of the valve is unstable, the control pressure can be further reduced at the needle valve in order to improve the control stability. This however increases the closing time of the regulator.

**Attention:** If the needle valve is closed, the excess pressure valve cannot close when it is taken into operation. This means the downstream pressure  $p_2$  inevitably increases to the same level as the upstream pressure  $p_1$ .

## 5. Dimensions in mm and weights

Nominal size	DN	125	150	200	250
Length	L	400	480	600	730
Height	H 1	460	590	730	730
Height	H 2	145	175	270	270
Weight for PN 16 <sup>1)</sup>	kg	75	118	260	305

<sup>1)</sup> 10 % for steel and spheroidal graphite iron PN 25

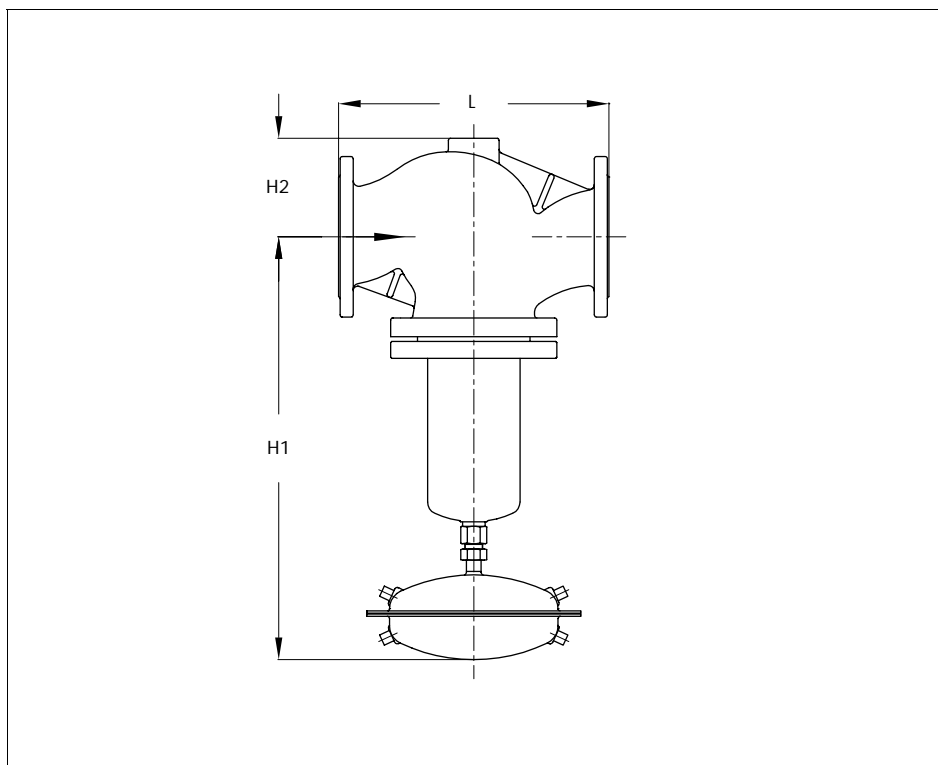

## 6. Customer inquiries

Should you have any inquiries about the valve, please submit the following details:

(see also the name plate)

1. Type and nominal size of the regulator
2. Product and order number
3. Upstream and downstream pressure
4. Temperature of the medium
5. Flow rate in m<sup>3</sup>/h
6. Has a strainer been installed?
7. Installation drawing



SAMSON AG · MESS- UND REGELTECHNIK  
Weismüllerstraße 3 · D-60314 Frankfurt am Main  
Postfach 10 19 01 · D-60019 Frankfurt am Main  
Telefon (0 69) 4 00 90 · Telefax (0 69) 4 00 95 07

**EB 2553-2 EN**

S/C 02.98