



### **1. Design and principle of operation**

The excess pressure valve consists of a globe valve with a plug, stem and balancing bellows as well as a black plastic section with a spring-loaded operating diaphragm and a set point adjustment.

The valve is designed to maintain the upstream pressure to an adjusted set point value.

The medium flows between the seat (2) and the plug (3) in the direction indicated by the arrow. The valve plug position determines the upstream pressure (excess pressure).

The upstream pressure is transmitted through a bore (6) in the valve body to the operating diaphragm (7) where it is converted into a positioning force. This positioning force is used to move the valve plug depending on the force of the spring(s) (8). The spring force can be adjusted by the set point adjustment (9).

## 2. Installation

### 2.1 Installation position

The excess pressure valve can be installed as desired. However, when handling liquids and

at temperatures above 60 °C, the valve must be installed in a horizontal pipe with the actuator hanging downwards.

The medium must flow through the valve in the direction indicated by the arrow on the valve body.

### 2.2 Strainer

Since sealing parts, globules and other impurities carried along by the medium can impair the proper functioning of the valve and particularly the tight shut-off of the valve, a strainer (SAMSON Type 1NI) must be installed upstream of the valve.

The strainer should be installed so that the medium flows through it in the direction indicated by the arrow on the strainer body. The

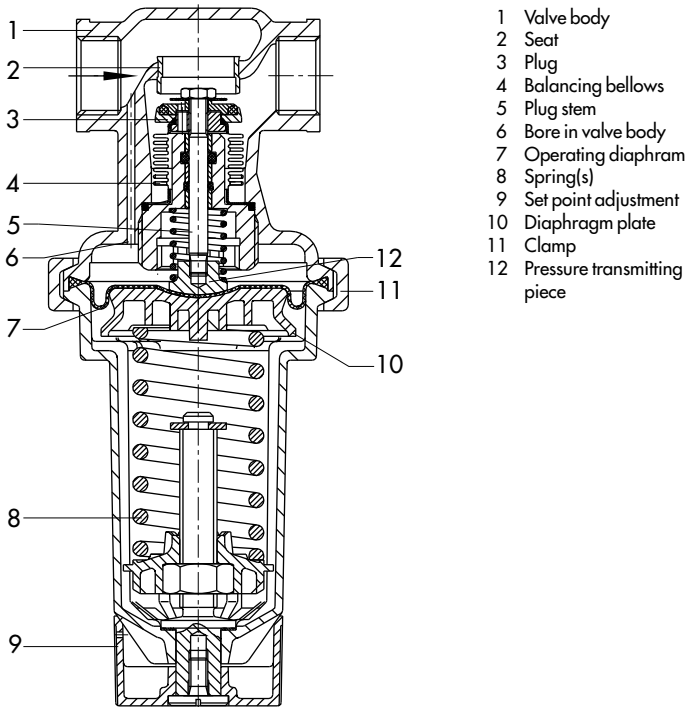

Fig. 2 · Sectional drawing

filter element must hang downwards when the strainer is installed in horizontal pipes and facing upwards when installed in vertical pipes. Make sure that there is sufficient space available to remove the filter.

### 2.3 Shut-off valves, pressure gauges

We recommend the installation of hand-operated shut-off valves both upstream of the strainer and downstream of the excess pressure valve. This allows the plant to be isolated for cleaning and maintenance work or when the plant is left unused for extended periods.

Install a pressure gauge both upstream and downstream of the excess pressure valve in order to be able to observe the pressures prevailing in the plant.

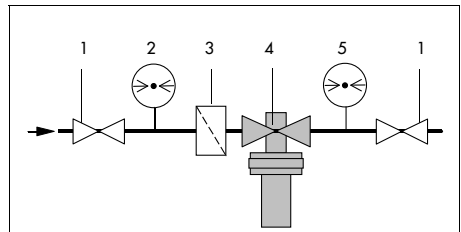

- 1 Shut-off valve
- 2 Upstream pressure gauge
- 3 Strainer
- 4 Excess pressure valve
- 5 Downstream pressure gauge

Fig. 3 · Typical installation

## 3. Operation

### 3.1 Set point adjustment

Adjust the required excess pressure by turning the set point adjustment (9). Turning it **clockwise** increases the upstream pressure and **anti-clockwise** reduces the upstream pressure.

Use the upstream pressure gauge to check the set point adjusted.

### 3.2 Faults

Should the excess pressure (upstream pressure gauge) deviate considerably from the adjusted set point, it may be caused by a dirty or worn seat and plug or due to natural wear. If the valve starts to leak, check the diaphragm and renew it, if necessary.



**When performing any assembly work on the excess pressure valve, it must first be removed from the pipeline. Prior to this, relieve the pressure from the corresponding part of the plant and drain it.**

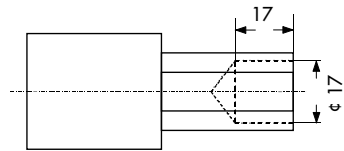

Fig. 4 · Socket wrench

### 3.2.1 Cleaning or replacing the plug

To disassemble the plug (3), a socket wrench (Order No. 1280-3001) is required. This wrench can also be made from, for example, a GEDORE screwdriver bit (IN 19-19) by boring a hole into the 19 mm hexagonal bit as illustrated in Fig. 4.

Completely relieve the tension from the spring(s) by turning the set point adjustment (9) anti-clockwise.

Unscrew the clamp (11) with caution as the spring is still slightly pre-tensioned.

Remove the black plastic section with the spring (8), diaphragm plate (10) and diaphragm (7). Remove the pressure transmitting piece (12).

Unscrew and take out the whole plug section (3).

Thoroughly clean the seat and plug.

If either the plug or metal bellows are damaged, the whole plug section must be renewed.

To reassemble, proceed in the reverse order. (Tightening torque for the plug section is 100 Nm).

### 3.2.2 Exchanging the diaphragm

Completely release the tension from the spring (8) by turning the set point adjustment (9) anti-clockwise.

Unscrew the clamp (11) with caution as the spring is still slightly pre-loaded.

Remove the black plastic section with the spring (10) and the diaphragm plate (10).

Take out the diaphragm and replace with a new one.

To reassemble the regulator, proceed in the reverse order.

### 5. Customer inquiries

In case of inquiries, please specify the following details:

(see also the name plate)

1. Type and nominal size of the excess pressure valve
2. Order and product number
3. Upstream and downstream pressure
4. Process medium and flow rate in  $\text{m}^3/\text{h}$
5. Has a strainer been installed?
6. Installation diagram

### 4. Dimensions and weights

Thread size	G 1/2	G 3/4	G 1
Length L	65	75	90
Weights, approx. kg	0.8	0.9	1

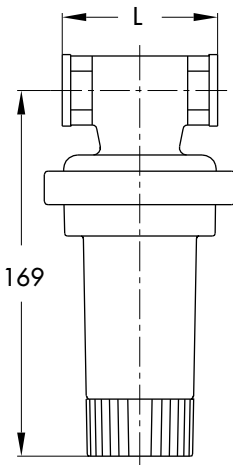

SAMSON AG · MESS- UND REGELTECHNIK  
Weismüllerstraße 3 · D-60314 Frankfurt am Main  
Postfach 10 19 01 · D-60019 Frankfurt am Main  
Telefon (0 69) 4 00 90 · Telefax (0 69) 4 00 95 07

**EB 2621-2 E**

S/C 02.97