

Self-operated Pressure Regulators



Pressure Reducing Valves

Type 44-0 B · Steam Pressure Reducing Valve

Type 44-1 B · Pressure Reducing Valve



Type 44-0 B Steam Pressure Reducing Valve, body with screwed ends, red brass



Type 44-1 B Pressure Reducing Valve, body with screwed ends, stainless steel

Mounting and Operating Instructions

EB 2626-1 EN

Edition December 2010



Contents

1	Design and principle of operation	4
1.1	Process medium, application	4
2	Installation	4
2.1	Mounting position	4
2.2	Strainer	6
2.3	Shut-off valve	6
2.4	Pressure gauge	6
3	Operation	7
3.1	Start-up	7
3.1.1	Steam regulation using Type 44-0 B	7
3.2	Adjusting the set point	7
3.3	Decommissioning	8
4	Maintenance and troubleshooting	8
4.1	Cleaning and replacing the plug	8
4.2	Replacing the operating bellows	9
4.3	Replacing the set point spring	9
5	Nameplate	11
6	Service	11
7	Technical data	12
8	Dimensions and weights	13

Definitions of the signal words used in these instructions

CAUTION!

indicates a hazardous situation which, if not avoided, could result in minor or moderate injury.

NOTICE

indicates a risk of property damage.

Note: *Supplementary explanations, information and tips.*

General safety instructions

Observe the following instructions on installation, start-up and operation of the regulator for your own safety:



- ▶ The regulator is to be mounted, started up or serviced by fully trained and qualified personnel only, observing the accepted industry codes and practices. Make sure employees or third persons are not exposed to any danger. All safety instructions and warnings in these mounting and operating instructions, particularly those concerning assembly, start-up and maintenance, must be observed.
- ▶ According to these mounting and operating instructions, trained personnel refers to individuals who are able to judge the work they are assigned to and recognize possible dangers due to their specialized training, their knowledge and experience as well as their knowledge of the applicable standards.
- ▶ The regulator fulfils the requirements of the European Pressure Equipment Directive 97/23/EC.
- ▶ For appropriate operation, make sure that the regulator is only used in areas where the operating pressure and temperatures do not exceed the sizing data specified in the order.
- ▶ The manufacturer does not assume any responsibility for damage caused by external forces or any other external influence!
- ▶ Any hazards that could be caused in the regulator by the process medium, the operating pressure or by moving parts are to be prevented by taking appropriate precautions.
- ▶ Proper transport, storage, installation, operation and maintenance are assumed.

Note! *Non-electric valve versions whose bodies are not lined with an insulating material coating do not have their own potential ignition source according to the risk assessment stipulated in EN 13463-1: 2009, section 5.2, even in the rare incident of an operating fault. Therefore, such valve versions **do not** fall within the scope of Directive 94/9/EC.*

For connection to the equipotential bonding system, observe section 6.3 of EN 60079-14: 2008 (VDE 0165-1).

1 Design and principle of operation

Also see Fig. 1 on page 5.

The pressure reducing valve consists of the valve (1) including the seat (3), plug (2) and balancing bellows (6) as well as an actuator section with operating bellows (5), set point spring (7) and set point adjuster (8/9).

The pressure reducing valve is designed to maintain the pressure downstream of the valve constant at the adjusted set point.

In pressureless state, the valve is open. It is closed when the downstream pressure exceeds the adjusted set point. The process medium flows through the valve in the direction indicated by the arrow on the body. The position of the valve plug (2) determines the flow rate across the area released between the plug and seat (3) and thus the pressure downstream of the valve.

The downstream pressure p_2 to be controlled is transmitted through a hole (4) in the valve body to the operating bellows (5) where it is converted into a positioning force. This force is used to move the plug depending on the force of the set point spring (7). The spring force can be adjusted on the set point adjuster (8/9).

1.1 Process medium, application

Type 44-0 B Pressure Reducing Valve for steam and **Type 44-1 B** for liquids and gases

Max. permissible temperatures:

- Gases up to **80 °C**
- Air up to **150 °C**
- Liquids up to **150 °C**
- Nitrogen up to **200 °C**
- Steam up to **200 °C**

2 Installation

Thoroughly flush the pipeline before installing the regulator to remove any sealing parts, weld spatter and other impurities carried along by the process medium that may impair the proper functioning of the valve, above all its tight shut-off.

Make sure the regulator is mounted free of stress. If necessary, support the piping near the connecting flanges. Never attach supports directly to the valve or actuator.

NOTICE

Install a strainer (e.g. SAMSON Type 2 NI with 0.25 mm mesh size) upstream of the regulator (refer to section 2.2).

2.1 Mounting position

Install the regulator with the direction of flow matching the arrow on the body.

- **Type 44-0 B, Type 44-1 B:** installation in horizontal pipelines with the actuator body pointing down.
- **Type 44-1 B:** installation in any desired position for medium temperatures up to 60 °C.



NOTICE

*Make sure no overheating occurs at the place of installation due to excessive ambient temperatures or insufficient heat dissipation. As a result, **never** insulate red brass bodies together with the medium pipeline.*

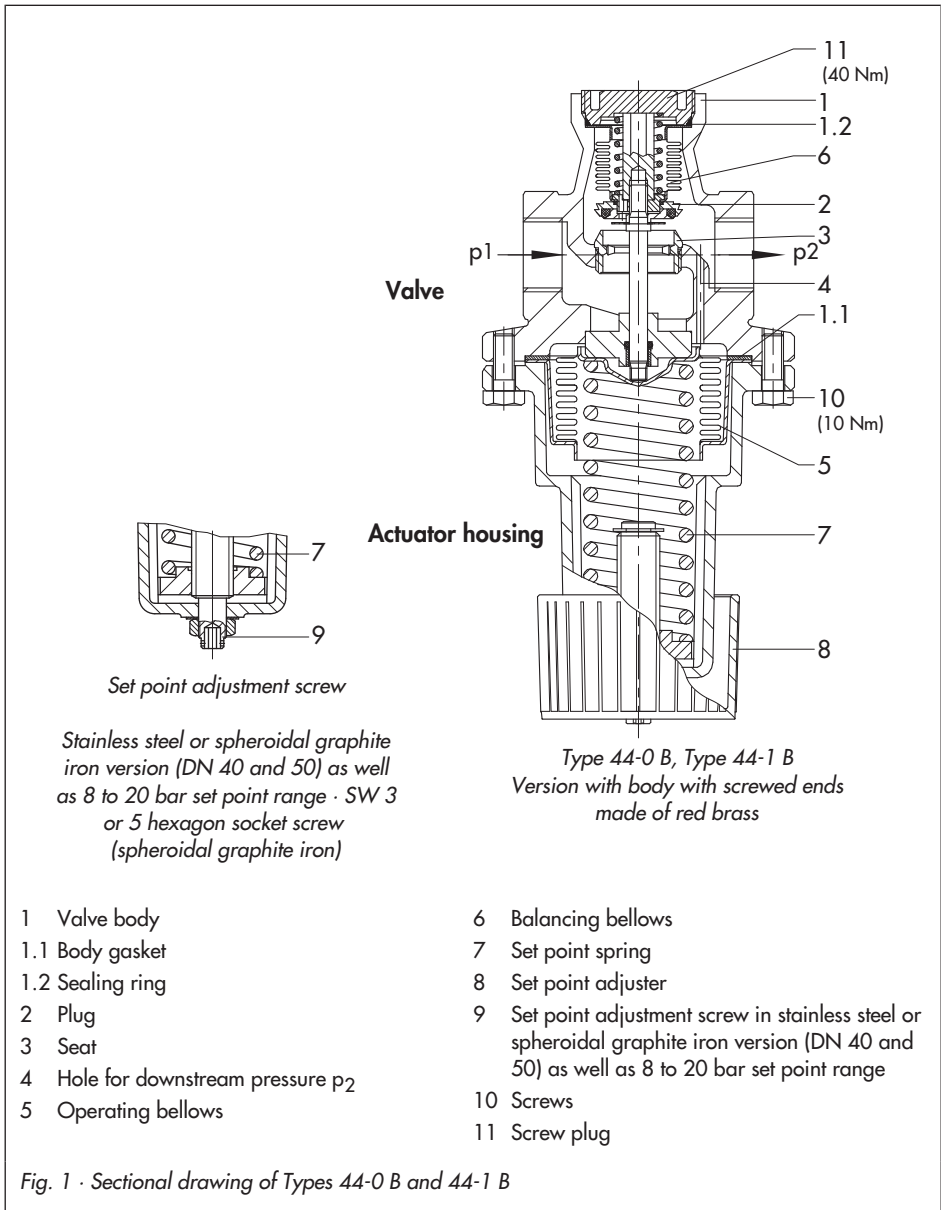

2.2 Strainer

Install a strainer upstream of the regulator (Fig. 2). Install the strainer with the direction of flow matching the arrow on the body.

In horizontal pipelines, install the strainer with the filter element vertically suspended. For steam applications, install the strainer with the filter element pointing to the side.

In vertical pipelines with the direction of flow from bottom to top, the drain flange of the filter element points up. In this case, dirt particles are not collected, but retained.

Remember to leave enough space to remove the filter element.

2.3 Shut-off valve

Install a hand-operated shut-off valve both upstream of the strainer and downstream of the regulator (Fig. 2) to be able to shut down the plant for cleaning and maintenance, and when the plant is not used for longer periods of time.

2.4 Pressure gauge

To monitor the pressures in the plant, install a pressure gauge both upstream and downstream of the regulator (Fig. 2).

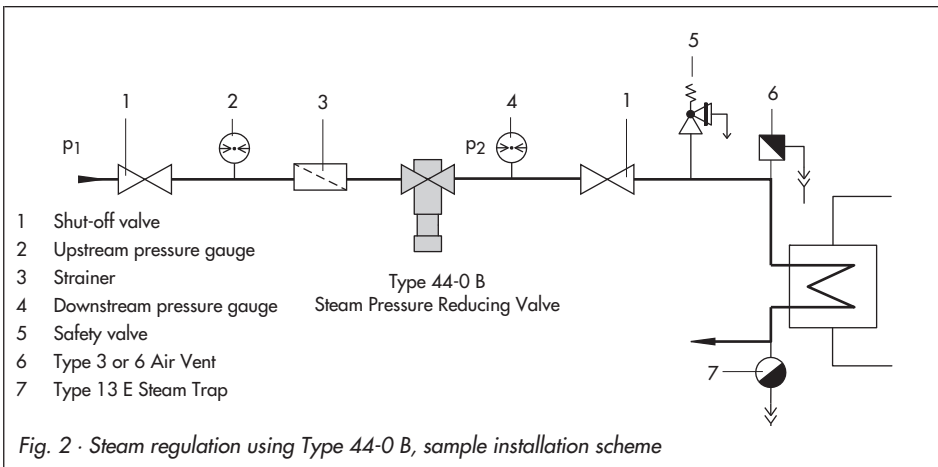

3 Operation

3.1 Start-up

CAUTION!

Do not start up the regulator before all components have been installed.

We recommend to open shut-off valves **slowly** from the upstream side. Avoid pressure surges.

NOTICE

When pressure-testing the pipelines with the regulator installed, make sure the regulator is not damaged by the test pressure.

Make sure the **maximum permissible pressure of 1.5 times the nominal pressure PN** is not exceeded.

Protect the regulator against frost when it is used to control freezing process media (e.g. water). When the regulator is not used for longer periods of time, remove it from the pipeline, if necessary.

3.1.1 Steam regulation using Type 44-0 B

- ▶ Drain the steam line and make sure it is absolutely dry to prevent water surges.
- ▶ Slowly fill the plant with steam so that the pipelines and valves heat up evenly and no excessive flow velocities occur.
- ▶ Drain the condensate produced during the start-up phase before the full capacity is reached.
- ▶ Make sure that the air contained in the plant is vented as quickly as possible.

NOTICE

Safely drain produced condensate from the pipeline (e.g. using a SAMSON Type 13 E Steam Trap).

Properly vent the plant (e.g. using a SAMSON Type 3 or Type 6 Air Vents).

3.2 Adjusting the set point

Also see Fig. 1 on page 5.

Adjust the desired set point by turning the set point adjuster (8) or set point adjustment screw (9).

Turn the set point adjuster or screw:

- ▶ Clockwise ↻
to increase the pressure set point
- ▶ Counterclockwise ↺
to reduce the pressure set point

Version with stainless steel or spheroidal graphite iron body (DN 40 or 50) as well as 8 to 20 bar set point range:

1. Loosen the lock nut.
2. Adjust the set point by turning the set point screw (9) clockwise or counterclockwise using an 3 or 5 mm Allen key (spheroidal graphite iron body).
3. Retighten the lock nut.

Check the adjusted set point on the pressure gauge installed downstream of the regulator (Fig. 2).

The set point range can be changed by replacing the set point spring (7; refer to section 4.3).

3.3 Decommissioning

We recommend to close the upstream shut-off valve before closing the shut-off valve downstream of the regulator.

4 Maintenance and troubleshooting

The pressure regulator is maintenance free. Nevertheless, it is subject to natural wear, particularly at the seat, plug and operating or balancing bellows.

Depending on the operating conditions, check the regulator at regular intervals to detect and remove possible malfunctions.

If external leaks occur, check the operating bellows (refer to section 4.2), and replace it, if necessary.

Refer to **Table 1** to determine the cause of existing faults and remove them. This may help to re-establish the regulator's proper functioning.

Note: Refer to Spare Parts List EL 2626 for original spare parts to be ordered from SAMSON (refer to section 6).

CAUTION!

For installation and maintenance work on the regulator, depressurize the relevant plant section and, depending on the process medium, drain it as well. We recommend to remove the regulator from the pipeline.

If necessary, allow the regulator to cool down to reach ambient temperature before starting any work on it.

As valves are not free of cavities, remember that residual process medium might still be contained in the valve.

4.1 Cleaning and replacing the plug

Also see Fig. 1 on page 5.

1. Relieve the set point spring (7) by turning the set point adjuster (8/9) counter-clockwise .
2. Unscrew the screw plug (11) using an SW 13 socket wrench. Pull out the balancing bellows (6) together with the plug (2) and plug stem.
3. Thoroughly clean the seat and plug. If the plug or balancing bellows are damaged, replace the entire assembly (remember that there is no balancing bellows with the standard plug for 0.2 to 2 bar set point range).
4. Replace the sealing ring (1.2) with a new one.
5. For assembly, proceed in reverse order. Observe the tightening torques given in Fig. 1.

4.2 Replacing the operating bellows

Also see Fig. 1 on page 5.

1. Relieve the set point spring (7) by turning the set point adjuster (8/9) counterclockwise \curvearrowright .

CAUTION!

Be careful when loosening the screws as the set point spring is still slightly pretensioned.

2. Unscrew the screws (10) evenly.
3. Remove the lower actuator section including spring (7) and operating bellows (5).
4. Remove the operating bellows and replace it with a new one.
5. Replace the body gasket (1.1) with a new one.
6. For assembly, proceed in reverse order. Observe the tightening torques given in Fig. 1.

4.3 Replacing the set point spring

Also see Fig. 1 on page 5.

The set point spring is located in the actuator housing. Remove the actuator housing from the valve to replace the spring.

1. Fully relieve the set point spring (7) by turning the set point adjuster (8/9) counterclockwise \curvearrowright all the way.

CAUTION!

Be careful when loosening the screws as the set point spring is still slightly pretensioned.

2. Unscrew the screws (10) evenly.
3. Remove the actuator section including set point spring (7) and operating bellows (5).
4. Remove the set point spring and replace it with a new one.
5. Replace the body gasket (1.1), if necessary.
6. For assembly, proceed in reverse order. Observe the tightening torques given in Fig. 1.

Table 1 · Troubleshooting and fault removal

Fault	Possible cause	Remedy
Pressure exceeds the adjusted set point	Insufficient pressure pulse on the operating bellows	Connect control line in special version without control line. Clean control line and screw joint.
	Pressure tapped in wrong location in special version with external control line	Reroute control line. Do not connect it to pipe elbows or necks.
	Wear on seat and plug due to deposits or foreign particles	Replace damaged parts.
	Plug blocked by foreign particles	Remove foreign particles. Replace damaged parts as necessary.
Pressure drops below the adjusted set point	Valve installed against the direction of flow	Check that valve is installed with the direction of flow matching the arrow on the valve body.
	Plug blocked by foreign particles	Remove foreign particles. Replace damaged parts as necessary.
	Pressure tapped in wrong location in special version with external control line	Reroute control line. Do not connect it to pipe elbows or necks.
	Valve too small or insufficient K_{VS}/C_V coefficient	Check valve sizing. Change K_{VS}/C_V coefficient or install suitable regulator.
Jerky control response	Increased friction, e.g. due to foreign particles in seat-plug trim	Remove foreign particles. Replace damaged parts as necessary.
Slow control response	Dirt inside control line impedes medium flow	Clean control line.
Downstream pressure fluctuates	Valve too large	Check valve sizing. Change K_{VS}/C_V coefficient or install suitable regulator.
	Pressure tapped in wrong location in special version with external control line	Reroute control line. Do not connect it to pipe elbows or necks.
Severe noise emissions	High flow velocity, cavitation	Check valve sizing. If necessary, install a larger regulator.

Special operating and installation conditions can lead to changed situations that may affect the control response and lead to malfunctions. In such cases, check the installation conditions, process medium, temperature and pressure conditions. A thorough analysis may require the on-site assistance of the SAMSON After-sales Service staff (refer to section 6).

5 Nameplate

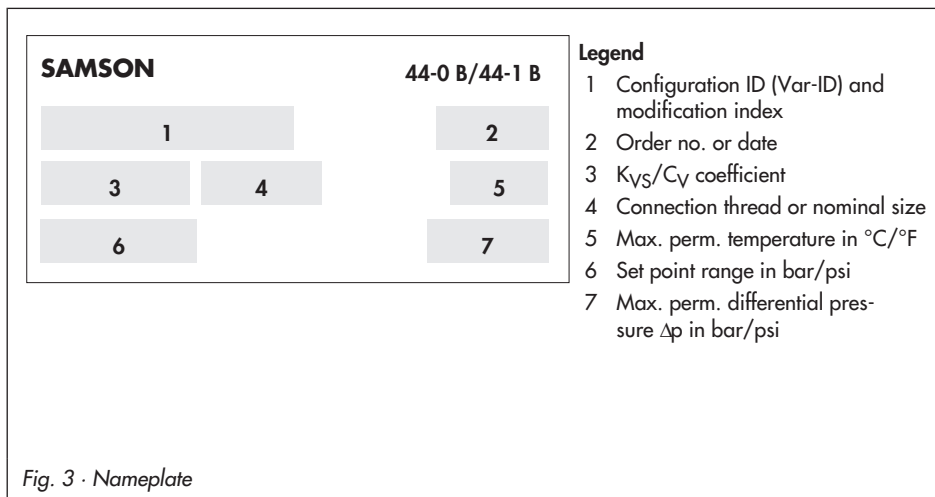

6 Service

If malfunctions or defects occur, contact the SAMSON After-sales Service for support.

The address of SAMSON AG, its subsidiaries, representatives and service facilities worldwide can be found on the Internet at www.samson.de, in a SAMSON product catalog or on the back of these mounting and operating instructions.

Include the following details (refer to section 5) when making inquiries:

- ▶ Type and nominal or thread size of the valve
- ▶ Configuration ID (Var-ID) and modification index
- ▶ Upstream and downstream pressures
- ▶ Temperature and process medium
- ▶ Min. und max. flow rates
- ▶ Has a strainer been installed?
- ▶ Installation drawing indicating the exact location of the regulator and all additionally mounted units (shut-off valves, pressure gauges etc.)

7 Technical data

Table 2 · Technical data · All pressures in bar (gauge)

Pressure reducing valve		Type 44-0 B	Type 44-1 B
Body connection	Stainless steel/red brass body	G ½, G ¾, G 1 female thread	
	Stainless steel body	DN 15 and 25 flanges	
	Sph. graphite iron body	DN 15, 25, 40 and 50 flanges	
Nominal pressure		PN 25	
Max. perm. temperature	Liquids	–	150 °C
	Non-flammable gases and air	–	80 °C
	Nitrogen	–	200 °C
	Steam	200 °C	–
Max. perm. diff. pressure	G ½, G ¾, G 1 · DN 15 and 25	16 bar	
	DN 40 und 50	8 bar	
Set point, continuously adjustable		0.2 to 2 bar · 1 to 4 bar · 2 to 6 bar · 4 to 10 bar 8 to 20 bar ¹⁾	
Leakage rate acc. to IEC 60534-4		≤ 0.05 % of K _{VS}	
Max. permissible ambient temperature		60 °C	

¹⁾ Set point range not for DN 40 and 50

Table 3 · K_{VS} coefficients

Body with screwed ends		G ½	G ¾	G 1
K _{VS} Type 44-1 B	Standard version	3.2 ¹⁾	4 ¹⁾	5 ¹⁾
	Unbalanced special version	0.25 ²⁾ · 0.4 · 1 ¹⁾ · 2.5		
Type 44-0 B	Standard version	1.6 ³⁾ · 3.2	2 ³⁾ · 4	2.5 ³⁾ · 5
	Unbalanced special version	0.25 ²⁾ · 0.4 ²⁾ · 1 ²⁾		

Flanged body	Nominal size	DN 15	DN 25	DN 40	DN 50
K _{VS} Type 44-1 B	Standard version	3.2 ¹⁾	5 ¹⁾	16	20
	Unbalanced special version	0.25 ²⁾ · 0.4 · 1 ¹⁾ · 2.5		8 ²⁾	
Type 44-0 B	Standard version	1.6 ³⁾ · 3.2	2.5 ³⁾ · 5	16	20
	Unbalanced special version	0.25 ²⁾ · 0.4 ²⁾ · 1 ²⁾		8 ²⁾	

¹⁾ Regulators with stainless steel bodies and FFKM soft seal also available as special versions

²⁾ Metal seal

³⁾ Unbalanced

8 Dimensions and weights

Body with screwed ends

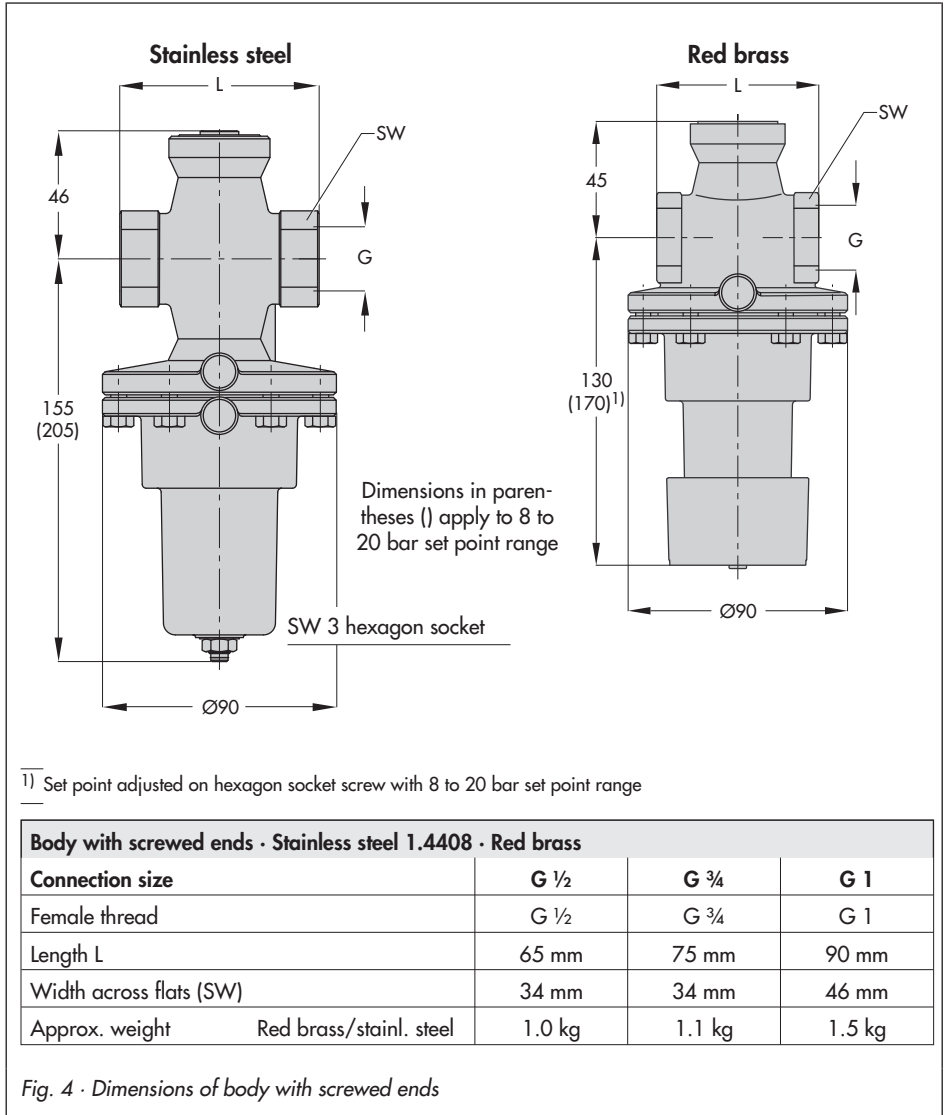
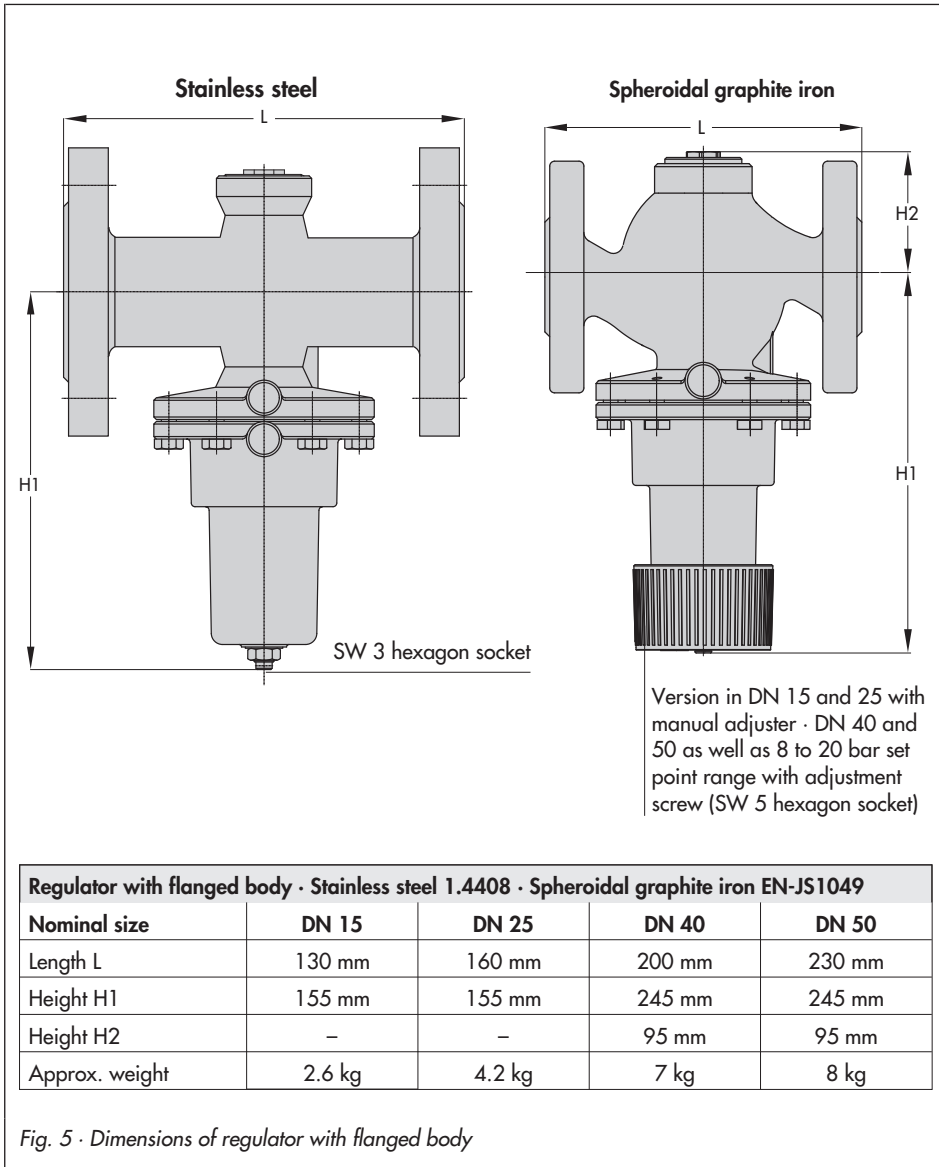

Fig. 4 · Dimensions of body with screwed ends

Flanged body





SAMSON AG · MESS- UND REGELTECHNIK
Weismüllerstraße 3 · 60314 Frankfurt am Main · Germany
Phone: +49 69 4009-0 · Fax: +49 69 4009-1507
Internet: <http://www.samson.de>

EB 2626-1 EN

S/Z/2013-08