

Series 2371 Pressure Regulators

SAMSON

Excess pressure valves for the
food and pharmaceutical industries

Type 2371-00 · Pneumatic set point adjustment

Type 2371-01 · Manual set point adjustment



Type 2371-00 Excess Pressure Valve
with pneumatic set point adjustment



Type 2371-01 Excess Pressure Valve
with manual set point adjustment
and stem locking

Mounting and Operating Instructions

EB 2642 EN

Edition March 2016



Definition of signal words



DANGER!

Hazardous situations which, if not avoided, will result in death or serious injury



WARNING!

Hazardous situations which, if not avoided, could result in death or serious injury



NOTICE

Property damage message or malfunction



Note:

Additional information



Tip:

Recommended action

1	General safety instructions	4
2	Process medium and scope of application	5
2.1	Transportation and storage	5
3	Design and principle of operation	5
4	Installation	10
4.1	Mounting position	10
4.2	Shut-off valve and pressure gauge.....	10
4.3	Safety valve	11
5	Operation	11
5.1	Start-up.....	11
5.2	Adjusting the set point	11
4.4	Leakage line connection	12
5.2.1	Set point · Type 2371-01	14
5.2.2	Set point · Type 2371-00.....	16
5.3	Operation	16
5.4	Decommissioning	16
6	Cleaning and maintenance	17
6.1	Cleaning	17
6.2	Maintenance · Replacing parts.....	21
6.3	Replacing the plug/diaphragm unit.....	21
6.3.1	Replacing the set point springs	24
7	After-sales service	25
8	Nameplate	26
9	Technical data	27
10	Dimensions	28



1 General safety instructions

- The regulator is to be mounted, started up, or serviced by fully trained and qualified personnel only; the accepted industry codes and practices are to be observed. Make sure employees or third persons are not exposed to any danger.
- All safety instructions and warnings given in these mounting and operating instructions, particularly those concerning installation, start-up, and maintenance, must be strictly observed.
- According to these mounting and operating instructions, trained personnel refers to individuals who are able to judge the work they are assigned to and recognize possible dangers due to their specialized training, their knowledge and experience as well as their knowledge of the applicable standards.
- To ensure appropriate use, only use the regulator in applications where the operating pressure and temperatures do not exceed the specifications used for sizing the regulator at the ordering stage.
- The manufacturer does not assume any responsibility for damage caused by external forces or any other external factors.
- Any hazards that could be caused in the regulator by the process medium, operating pressure or by moving parts are to be prevented by taking appropriate precautions.
- Proper transport, storage, installation, operation, and maintenance are assumed.



Note:

Non-electric actuators and control valve versions do not have their own potential ignition source according to the ignition risk assessment stipulated in EN 13463-1: 2009, section 5.2, even in the rare incident of an operating fault. Therefore, they do not fall within the scope of Directive 94/9/EC.

For connection to the equipotential bonding system, observe the requirements specified in section 6.3 of EN 60079-14: 2014-10 (VDE 0165 Part 1).

2 Process medium and scope of application

Excess pressure valves for food processing and pharmaceutical industries for liquids and gases in the pressure range from 0.3 to 6 bar (5 to 90 psi) · K_{VS} 0.1 to 25 (C_V 0.12 to 30) · Nominal size DN 15 to 50 (NPS ½ to 2) · Suitable for liquids and gases from 0 to +160 °C (32 to 320 °F) · Max. operating pressure (input pressure) 10 bar (150 psi)

For controlling the upstream pressure p_1 to the adjusted set point. The valve opens when the upstream pressure rises.



NOTICE

The Type 2371-00 and Type 2371-01 Regulators are designed as safety valves. Exceeding the maximum pressure (10 bar/150 psi) of the regulator may cause it to burst. If necessary, a suitable overpressure protection must be installed on site in the plant section.



Note:

The Type 2371-00 and Type 2371-01 Regulators are shut-off devices that do not guarantee absolute tight shut-off (leakage class according to IEC 60534-4 or ANSI/FCI 70-2, see section 9). As a result, the output pressure p_2 can rise to the same level as the input pressure p_1 in a plant which does not have its own consumption.

2.1 Transportation and storage

The regulators must be carefully handled, transported, and stored. During storage and transportation, protect the regulators against adverse influences, such as dirt, moisture, or temperatures outside the operating temperature range.

3 Design and principle of operation

See Fig. 1 on page 7.

The Type 2371-00 and Type 2371-01 Excess Pressure Valves consist mainly of a single-seated angle valve with operating diaphragm and actuator housing.

The set point of the **Type 2371-00** is adjusted **pneumatically** by an external air supply, e.g. compressed air.

The set point of **Type 2371-01** is adjusted **manually** by tensioning the set point spring.

The medium flows through the valve body (1) in the direction indicated by the arrow. The position of the plug (3) determines the flow rate across the area released between plug and valve seat (2).

The valve is closed in the normal position. The valve opens when the upstream pressure p_1 rises above the adjusted pressure set point. The resulting input pressure p_1 depends on the flow rate.

Any medium escaping from the test connection (11) indicates that the operating diaphragm (4/4.1) may be leaking or the diaphragm has ruptured.

The test connection of Type 2371-00 ($K_{Vs}/C_v = 25/30$) is connected to a flexible pipe elbow to discharge any medium escaping.

Type 2371-01 · Version with manual set point adjustment (see section 5.2.1)

In the idle state, the valve is kept closed by the set point springs (7). The valve opens when the input pressure p_1 acting on the diaphragm (4) and the resulting force exceed the force of the springs.

The set point is adjusted using an Allen key (8 mm), which is inserted through the adjustment opening (6.1) on top of the housing onto the set point screw (6). The blanking plug must first be removed. If necessary, the set point screw can be secured by the locking screw (12) in the upper plug section to prevent the set point screw from loosening due to vibrations, causing the set point to change.

Turning the set point screw clockwise causes the spring plate (7.1) to move upwards and

increases the spring force and the set point. Turning the set point screw counterclockwise relieves the spring tension and reduces the set point.

Type 2371-00 · Version with pneumatic set point adjustment (see section 5.2.2)

In the idle state, the valve is kept closed by the set point pressure p_C applied as the control pressure.

When the force created by the input pressure p_1 acting on the diaphragm exceeds the force resulting from the set point pressure p_C , the plug (3) moves towards the seat (2), opening the passage. In this case, the ratio between p_1 and p_C is not necessarily 1:1.

As the input pressure p_1 drops, the resulting force reduces again. The valve is closed again when the pressure falls below the external set point pressure p_C .

The two diaphragms (4.1) provide a certain amount of safety when one of the diaphragms ruptures and prevents the process medium and external pressure medium (e.g. compressed air) from mixing.

The screw (12) prevents parts from falling apart inadvertently while the regulator is being dismantled.

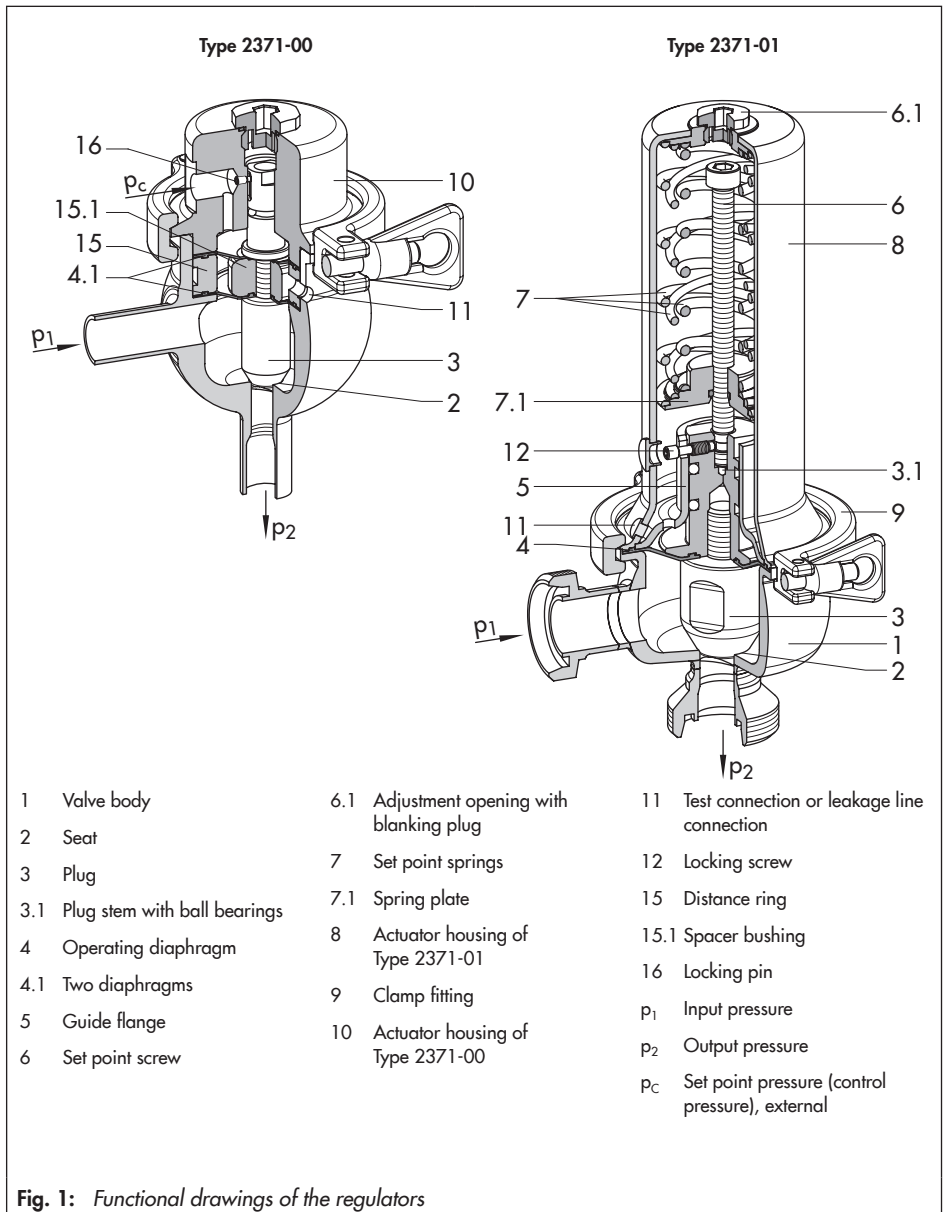

Fig. 1: Functional drawings of the regulators

Stem locking for CIP or SIP

See section 6.1 on page 17.

The Type 2371-00 and Type 2371-01 Excess Pressure Valves can be fitted with a stem locking to keep the plug in the open position.

In the version with stem locking, the plug can be locked in the open position to allow the valve to be cleaned (CIP = Cleaning In Place or SIP = Sterilization In Place) while it is open.

The stem can be locked in place pneumatically by an additional pneumatic actuator with compressed air connection (for Type 2371-00 and Type 2371-01) or manually using a lever with clamping fixture (Type 2371-01 only).

The pneumatic and manual stem locking do not effect the control function of the valve, provided the stem locking is not engaged.

The additional pneumatic actuator for the pneumatic stem locking is located on the top of the regulator. The unit can be mounted in any position since the axial fixture of the unit allows it to turn 360°.

The clamping fixture of the manual stem locking is directly connected with the plug over the set point screw to allow the plug stem and plug to be pushed into the open position and locked in place.

Additional pneumatic actuator for stem locking

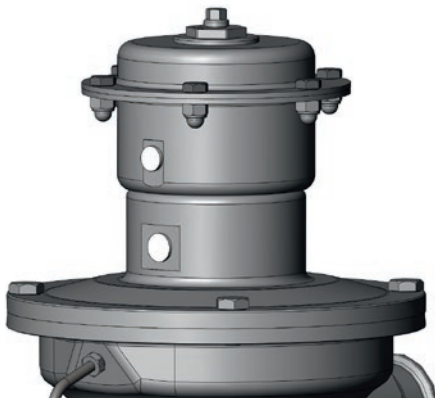

Type 2371-00 · Pneumatic stem locking

Lever with clamping fixture for stem locking



Type 2371-01 · Manual stem locking

Fig. 2: Stem locking for CIP or SIP

Pneumatic stem locking**Type 2371-00**

To open the valve, apply a pressure $p_V = 1$ bar to the additional pneumatic actuator. This causes the plug stem to move together with the plug out of the valve seat. A set point pressure p_C must not be applied to the regulator in this case.

To switch the valve back to its control function, remove the pressure $p_V (= 1 \text{ bar})$. The spring pulls the internal actuating unit back, allowing the plug stem to move again for the control task.

Apply the external set point pressure p_C again for the control task.

Type 2371-01

To open the valve, apply a pressure $p_V (= 6 \text{ bar})$ to the additional pneumatic actuator. This causes the plug stem to move together with the plug out of the valve seat and opens the valve. To switch the valve back to its control function, remove the pressure $p_V (= 6 \text{ bar})$. The spring pulls the internal actuating unit back, allowing the plug stem to move again for the control task.

Manual stem locking**Type 2371-01**

Type 2371-01 can also be fitted with a manually operated stem locking.

The lever together with the clamping fixture is directly connected with the plug over the set point screw.

When the lever is pushed manually to the other side, the plug is pushed, opposing the spring force, into the open position and locked in place.

Push the lever back to allow the regulator to continue its control task.

4 Installation

! NOTICE

Pay particular attention to correct hygiene and ensure that regulators for the food and pharmaceutical industries are kept absolutely clean. The tools used must be free of solvents and grease. Only use a lubricant suitable for foodstuffs (order no. 8150-9002) for parts that must be lubricated.

Choose a place of installation that allows you to freely access the regulator even after the entire plant has been completed and allows unobstructed set point adjustment.

Before installing the regulator in the pipeline, clean the pipeline thoroughly to remove any foreign particles in the plant which could affect the regulator's proper functioning.

The plant must be designed and the pipelines installed in such a way that the regulator can be mounted and operated without any tension. If necessary, support the pipeline near to the connections. Do not attach supports to the regulator itself.

Select a straight section of pipeline without any disturbances as the site of installation for the regulator (to ensure that the control function is not affected by the flow conditions).

! NOTICE

Protect the regulator from icing up when controlling media that can freeze. Remove the regulator from the pipeline when the plant is shut down if the regulator is not installed areas free from frost.

4.1 Mounting position

The regulator has an angle-style valve body.

The actuator housing must face upwards.



The inlet connection for p_1 is in the horizontal position.

- The direction of flow must match the direction indicated by the arrow on the body (inlet at the side and outlet at the bottom).

4.2 Shut-off valve and pressure gauge

Install a manually operated shut-off valve upstream and downstream of the regulator. This allows the plant to be depressurized, if required. In addition, it serves to relieve the operating diaphragm of pressure when the plant is not operated for extended periods.

A pressure gauge upstream of the regulator allows the set point (to control the input pressure p_1) to be monitored.

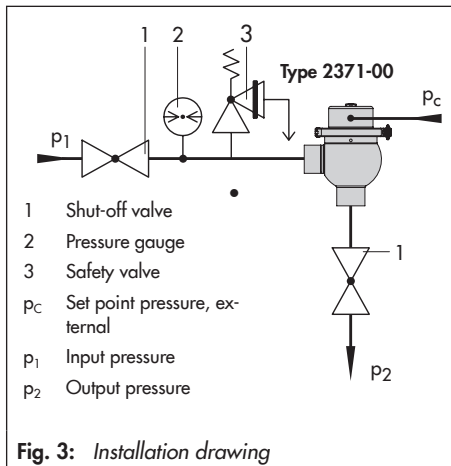

4.3 Safety valve

The Types 2371-00/-01 Excess Pressure Valves are not shut-off devices guaranteeing tight shut-off (leakage class, see section 9).

NOTICE
The pressure in the entire system must not exceed the maximum permissible pressure. Corresponding safety equipment (e.g. safety valve) must be installed upstream of the regulator. Ensure that the regulator itself cannot exceed the maximum pressure of 10 bar (150 psi).

The permissible temperature and pressure limits are specified on the regulator.

¹⁾ External supply air (e.g. compressed air, $p_{\max} = 8$ bar) required

5 Operation

5.1 Start-up

First start up the regulator after mounting all parts.

Fill the plant slowly with the process medium. Avoid pressure surges. Open the shut-off valves first on the upstream pressure side. Afterwards, open all the valves on the consumer side (downstream of the regulator).

Note:
For optimal control, the required pressure set point must be within the top end of the setting range.

5.2 Adjusting the set point

The set point must be adjusted on starting up the plant running under normal operating conditions.

The pressure gauge located on the upstream pressure side allows the adjusted pressure set point to be monitored.

- The set point adjustment in Type 2371-10 is pneumatic ¹⁾ over an external control pressure.
- The set point of Type 2371-01 is adjusted manually by tensioning the set point springs.

4.4 Leakage line connection

A leakage line can be connected to the regulator when toxic or dangerous media are used. In the event of a defective diaphragm (e.g. diaphragm rupture), any process medium that escapes can be fed through a pipe to a safe location.

Adapt the pipe diameter to the connection at the regulator.

5.2.1 Set point · Type 2371-01

Manual set point adjustment · See Fig. 1 on page 7.

The set point is adjusted for the lowest pressure set point in the delivered state. The locking screw (12) is **not** tightened.

NOTICE

Observe the set point range of the regulator. Do not load the set point spring (7) too far with the set point screw (6). Otherwise, the travel will be restricted or the valve blocked in the closed position.

The valve opens when the input pressure p_1 exceeds the pressure adjusted set point.

5. Retighten the locking screw ¹⁾ (12) to prevent the set point screw (6) from being turned.
 - Reinsert the stopper.

How to proceed:

1. Remove the stopper. Use an Allen key (3 mm) to undo the locking screw (12) if it is tightened (two turns counterclockwise).
2. Use an Allen key (8 mm) to remove the blanking plug (6.1).
3. Place the key through the opening to reach the set point screw (6).
4. Turn the set point screw to adjust the set point:
 - Turn clockwise \curvearrowright : increases the pressure set point.
 - Turn counterclockwise \curvearrowleft : reduces the pressure set point.

Monitor the upstream pressure at a pressure gauge (see Fig. 3).

¹⁾ The locking screw only needs to be tightened if the set point may be possibly be affected by, for example, vibrations.

1.

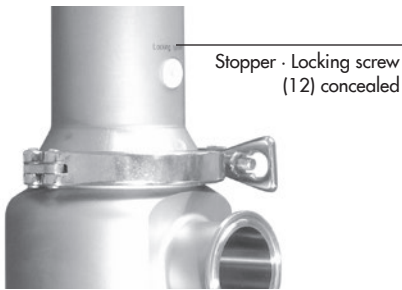

Position of the locking screw (12) with stopper

2.

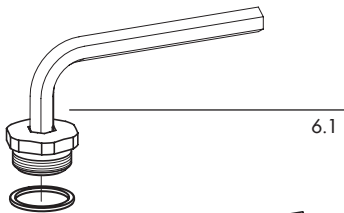

3.

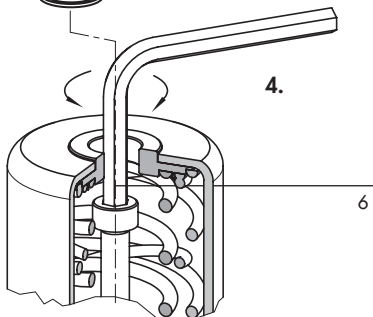

Fig. 4: Set point adjustment of Type 2371-01

5.2.2 Set point · Type 2371-00

Pneumatic set point adjustment · See Fig. 1 on page 7.

How to proceed:

1. Connect the set point pressure line at the G $\frac{1}{4}$ connection. Max. pressure $p_C = 8$ bar.
2. Adjust the set point pressure p_C to obtain and keep the required pressure constant.

Monitor the upstream pressure at a pressure gauge (see Fig. 3).

The valve opens when the input pressure p_1 exceeds the pressure adjusted set point.

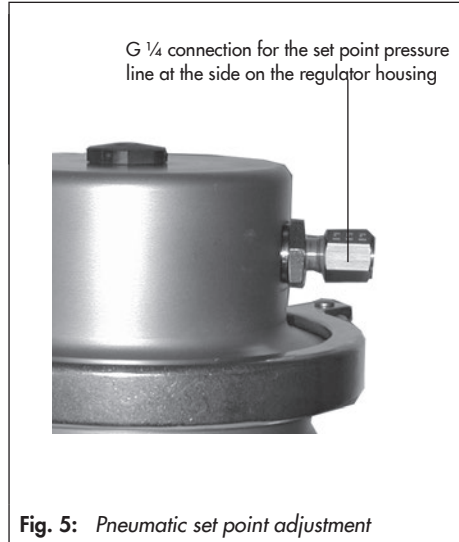

Fig. 5: *Pneumatic set point adjustment*

5.3 Operation

A correctly sized Type 2371-00/-01 Excess Pressure Valve works automatically within its control range.

We recommend after every start-up to check that the regulator functions properly and to adapt it to new operating conditions, if necessary.

5.4 Decommissioning

Close the shut-off valve upstream of the valve and then close the shut-off valve downstream of the valve.



NOTICE

Before performing any work on the regulator, make sure the relevant plant section has been depressurized and, depending on the process medium, drained as well.

6 Cleaning and maintenance

The regulators do not require any maintenance. Nevertheless, they are subject to natural wear, particularly at the seat, plug, and operating diaphragm.

Depending on the operating conditions, check the regulator at regular intervals to avoid possible malfunctions.



WARNING!

Before performing any work on the regulator, make sure the relevant plant section has been depressurized and, depending on the process medium, drained as well. We recommend removing the valve from the pipeline. When used at high temperatures, allow the plant section to cool down to ambient temperature. As valves are not free of cavities, remember that residual process medium might still be contained in the valve.

Check the seat and plug for wear. Check that the PTFE layer of the diaphragm (see Fig. 1, Fig. 9, and Fig. 10) is not damaged (e.g. cracks, milky coloring at the bends). This is necessary for compliance with EU 1935/2004.

If leakage still occurs and there is no visible signs of damage on the diaphragm, check the connection between the plug support and plug stem or the clamped connection between the valve body and bonnet (see section 6.2 on page 21).

Tighten the connection to achieve a leak-proof joint.

6.1 Cleaning

In the version with stem locking, the plug can be locked in the open position to allow the valve to be cleaned (CIP = Cleaning In Place or SIP = Sterilization In Place) while it is open (see Stem locking for CIP or SIP on page 8).

Stem locking: Pneumatic for Type 2371-00 · Manual for Type 2371-01

The disengaged stem locking does not affect the regulator's control function.

Manual stem locking (Type 2371-01 only)

See *Stem locking for CIP or SIP* on page 8.

The lever together with the clamping fixture is directly connected with the plug over the set point screw.

How to proceed:

1. Push the lever manually to the other side. This causes the plug to be pushed, opposing the spring force, into the open position and locked in place.
2. Push the lever back to allow the regulator to continue its control task.

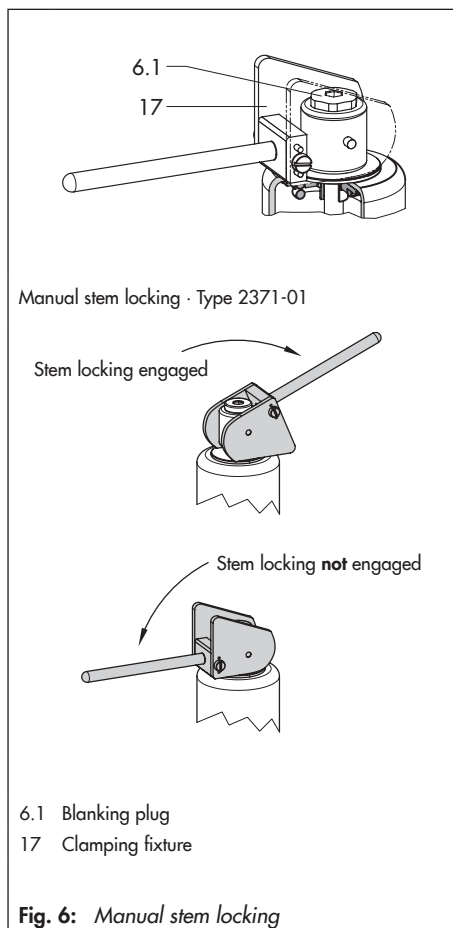

Pneumatic stem locking (Type 2371-01)

See *Stem locking for CIP or SIP* on page 8.

Type 2371-01

To open the valve, apply a pressure $p_V (= 6 \text{ bar})$ to the additional pneumatic actuator. This causes the plug stem to move together with the plug out of the valve seat and opens the valve.

How to proceed:

1. Connect the pressure line with min. 6 mm diameter to the G $\frac{1}{8}$ connection at the side of the additional actuator.
2. Apply a pressure $p_V = 6 \text{ bar}$ to the additional actuator. This causes the set point screw (6) to move and the plug to move out of the valve seat and opens the valve.
3. To switch the valve back to its control function, remove the pressure $p_V = 6 \text{ bar}$ to return the pressure back to atmospheric pressure. The spring (18) pulls the internal actuating unit (17) back, allowing the plug stem to move again for the control task.

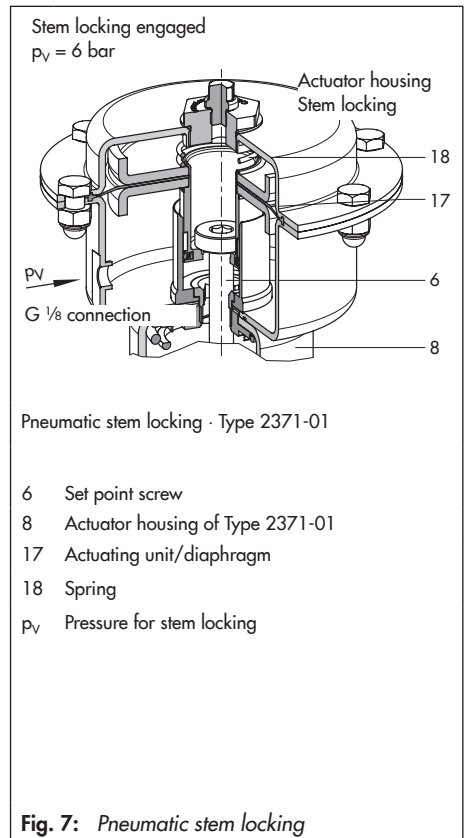

Pneumatic stem locking · Type 2371-00

See *Stem locking for CIP or SIP* on page 8.

Type 2371-00

To open the valve, apply a pressure $p_v (= 1 \text{ bar})$ to the additional pneumatic actuator. This causes the plug stem to move together with the plug out of the valve seat and opens the valve. Do not apply a set point pressure p_c to the regulator in this case.

How to proceed:

1. Connect the pressure line with min. 6 mm diameter to the G $\frac{1}{8}$ connection at the side of the additional actuator.
2. Apply a pressure $p_v = 1 \text{ bar}$ to the additional actuator. This causes the set point screw (6) to move and the plug to move out of the valve seat and opens the valve.
3. To switch the valve back to its control function, remove the pressure $p_v = 1 \text{ bar}$ to return the pressure back to atmospheric pressure. The spring (18) pulls the actuating unit (17) back, allowing the plug stem to move again for the control task.

Apply the set point pressure p_c again for the control task.

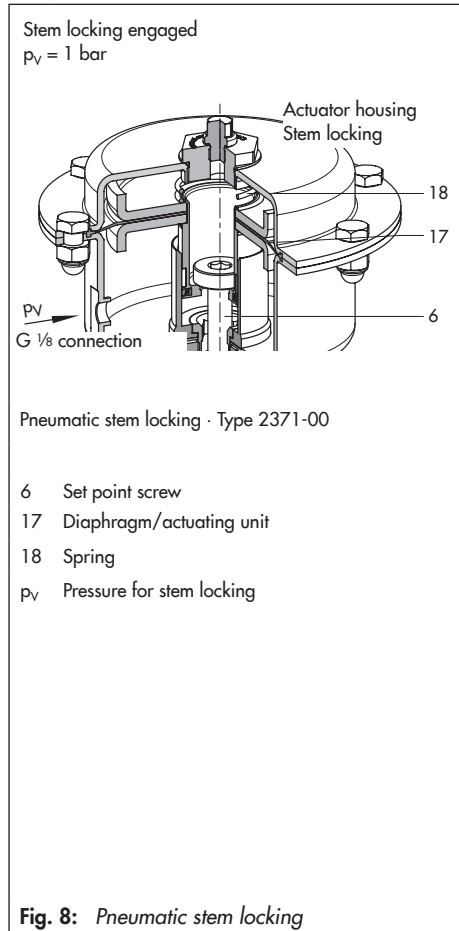

6.2 Maintenance · Replacing parts

See Fig. 1 on page 7.

The regulator is subject to natural wear. Depending on the operating conditions and duration of operation, regularly check the regulator's ability to function.

If the upstream pressure drops even though the set point has not been reached, the valve does not shut off tightly enough. This may happen when the tight shut-off is impaired by either dirt or natural wear on the seat and plug, or if the flow rate of the process medium is smaller than the permissible leakage rate of the regulator. However, it is important to take into account that a maximum leakage of 0.05 % of the K_{VS} or C_V coefficient in the case of metal-seated plugs and 0.01 % in the case of soft-seated plugs is still permissible (see section 9).

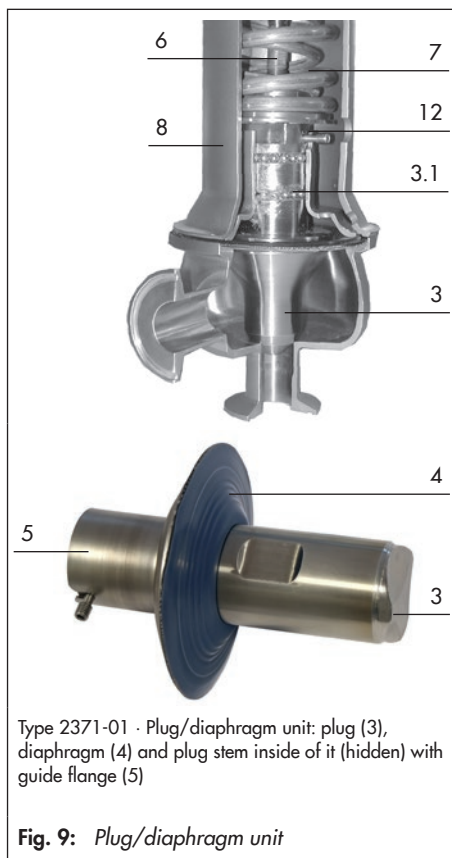

6.3 Replacing the plug/diaphragm unit

In the event that the diaphragm or plug is defective, we recommend replacing the entire plug/diaphragm unit (plug, diaphragm, and plug stem). Contact SAMSON if you intend to replace just the diaphragm or plug.

Type 2371-01

How to proceed:

1. Relieve the tension from the set point springs. See section 5.2.
2. Release clamp fitting. Undo the locking screw (12). Lift out the actuator housing (8) together with set point screw (6) and set point springs (7).

3. Remove the guide flange (5) together with the plug stem, diaphragm (4), and plug (3) out of the valve body.
4. Remove the locking screw (12). Carefully pull off the guide flange (5).



Note:

The ball bearings embedded in food grade lubricant are uncovered. Take the ball bearings out of the grooves and keep them at hand for the reassembly.

Prior to installing the new unit, check the plug seat and facing for damage. In case of damage, replace the entire valve body.

5. Insert the ball bearings with food grade lubricant into the grooves of the plug stem of the new unit. Slide the guide flange (5) over the plug stem. Thread in the locking screw (12). Place the unit into the open valve body. Make sure that the diaphragm rests neatly in place.
6. Carefully place the actuator housing onto the valve body. Make sure that the locking screw (12) does not project into the borehole intended for the set point screw. Ensure that the borehole at the side of the housing is aligned with the locking screw.
7. Position the clamp fitting. Grease the groove and screw with food grade lubricant. Hit the clamp lightly with a plastic hammer and tighten the clamp screw again until the parts fit properly.



Type 2371-01 - Diaphragm with guide flange inserted into the valve body.

Fig. 10: Plug/diaphragm unit with the lower housing section

Type 2371-00

How to proceed:

1. Remove the pressure line(s), if attached, and undo the clamp fitting.
2. Unthread the locking pin (16).
3. Carefully lift off the actuator housing (10).



NOTICE

The plug stem (3.1) with the ball bearings embedded in food grade lubricant are uncovered. Take the ball bearings out of the grooves and keep them at hand for the reassembly.

Prior to installing the new unit, check the plug seat and facing for damage. In case of damage, replace the entire valve body.

4. Place the new unit into the open valve body. Make sure that the diaphragm rests neatly in place. Insert the ball bearings with food grade lubricant into the grooves of the plug stem of the new unit.

5. Carefully slide the actuator housing (10) over the plug stem. Thread in locking pin (16). Stick the locking pin in place with adhesive (order no. 8121-9001).
6. Position the clamp fitting. Grease the groove and screw with food grade lubricant. Hit the clamp lightly with a plastic hammer and tighten the clamp screw again until the parts fit properly.



Note:

The locking pin (16) prevents the actuator housing from being pulled off the plug stem unintentionally. The plug stem must still be able to move axially in the housing. Do **not** clamp the plug stem to the housing with the locking pin.

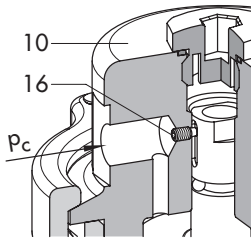

Actuator housing (10) with set point pressure port p_c and locking pin (16)



Actuator housing (10) removed. Plug stem (3.1) with ball bearings and top diaphragm (4.1) accessible.

Fig. 11: Plug/diaphragm unit

6.3.1 Replacing the set point springs

Type 2371-01

The regulator does not need to be removed from the pipeline.

You need to replace the set point springs (7) with both plates to achieve a different set point range. We recommend changing the entire actuator housing (8) with set point springs (7) and set point screw (6).

How to proceed:

1. Relieve the tension from the set point springs. Proceed as described in section 5.2.
2. Release clamp fitting. Lift out the actuator housing (8) together with set point screw (6) and set point springs (7).
3. Place on the new housing with new set point springs.

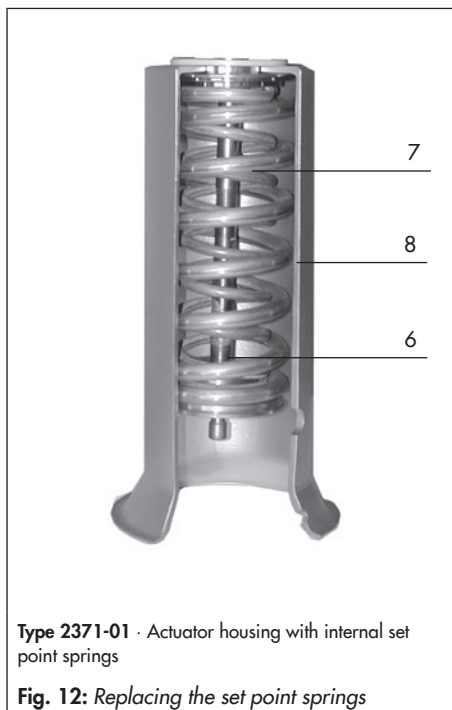

Type 2371-01 · Actuator housing with internal set point springs

Fig. 12: Replacing the set point springs

7 After-sales service

Contact SAMSON's After-sales Service department for support concerning maintenance or repair work or when malfunctions or defects arise.

E-mail

You can reach the After-sales Service Department at aftersaleservice@samson.

Addresses of SAMSON AG and its subsidiaries

The addresses of SAMSON AG, its subsidiaries, representatives, and service facilities worldwide can be found on the SAMSON website (► www.samson.de) in all SAMSON product catalogs or on the back of these Mounting and Operating Instructions.

To assist diagnosis and in case of an unclear mounting situation, specify the following details:

- Type designation and modification index
- Nominal size DN
- Serial number
- Temperature and process medium
- Is a strainer installed?
- Installation drawing showing the exact location of the regulator and all the additionally installed components (shut-off valves, pressure gauge, etc.)

8 Nameplate

The nameplate specifications are located on the regulator housing.

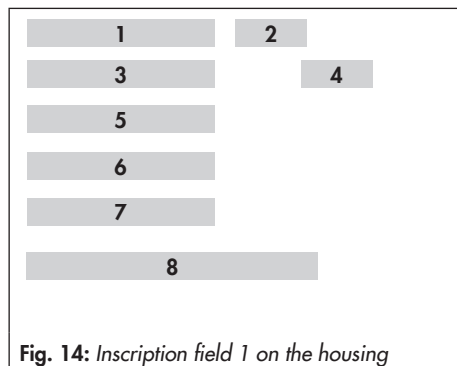

Fig. 14: Inscription field 1 on the housing

Comments:

- 1 Type designation
- 2 Modification index
- 3 Nominal size DN
- 4 Material numbers according to DIN EN
- 5 Maximum pressure in bar at 20 °C
Maximum pressure in psi at 70 °F
- 6 Maximum operating temperature in °C or °F
- 7 Flow coefficient K_{VS} (m³/h)
or C_v (US gal/min)
ME = Metal seal
PK = Soft seal
- 8 Serial number

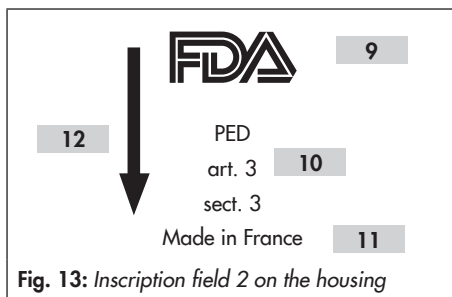

Fig. 13: Inscription field 2 on the housing

Comments:

- 9 Mark of conformity (food)
- 10 PED labeling
- 11 Made in France/year of manufacture
- 12 Arrow indicating the direction of flow



Note:

Each regulator can be clearly identified by the specifications written on the nameplate. Therefore, do not cover or write over the specifications on the nameplate.

9 Technical data

Table 1: Technical data · All pressures (gauge)

Types 2371-00/-01 Excess Pressure Valve		DIN					
Valve size		DN 15	DN 20	DN 25	DN 32	DN 40	DN 50
Set point ranges	Type 2371-00	0.3 to 6 bar					
	Type 2371-01	0.3 to 1.2 bar · 1 to 3 bar · 2.5 to 4.5 bar · 4 to 6 bar					
Maximum pressure		10 bar					
Max. perm. temperatures	Operating temp. range	0 to 160 °C					
	Sterilizing temperature	180 °C for up to 30 minutes					
Leakage class according to IEC 60534	Metal seal	Class I (≤ 0.05 % of K_{VS} coefficient)					
	Soft seal	Class IV (≤ 0.01 % of K_{VS} coefficient)					
Peak-to-valley height and surface finish	External	Glass bead blasted ¹⁾ · $R_a \leq 0.6 \mu\text{m}$, polished					
	Internal	$R_a \leq 0.8 \mu\text{m}$, precision-lathed ¹⁾ · $R_a \leq 0.6 \mu\text{m}$, polished $R_a \leq 0.4 \mu\text{m}$, satin finish · $R_a \leq 0.4 \mu\text{m}$, mirror finish					
Compliance		ERC					
Types 2371-00/-01 Excess Pressure Valve		ANSI					
Valve size		NPS ½	NPS ¾	NPS 1	NPS 1¼	NPS 1½	NPS 2
Set point ranges	Type 2371-00	5 to 90 psi					
	Type 2371-01	5 to 18 psi · 1.5 to 45 psi · 35 to 65 psi · 60 to 90 psi					
Maximum pressure		150 psi					
Max. perm. temperatures	Operating temp. range	32 to 320 °F					
	Sterilizing temperature	356 °F for up to 30 minutes					
Leakage class according to ANSI/FCI 70-2	Metal seal	Class I (≤ 0.05 % of C_V coefficient)					
	Soft seal	Class IV (≤ 0.01 % of C_V coefficient)					
Peak-to-valley height and surface finish	External	Glass bead blasted ¹⁾ · $R_a \leq 0.6 \mu\text{m}$, polished					
	Internal	$R_a \leq 0.8 \mu\text{m}$, precision-lathed ¹⁾ · $R_a \leq 0.6 \mu\text{m}$, polished $R_a \leq 0.4 \mu\text{m}$, satin finish · $R_a \leq 0.4 \mu\text{m}$, mirror finish					
Compliance		ERC					

¹⁾ Standard version

10 Dimensions

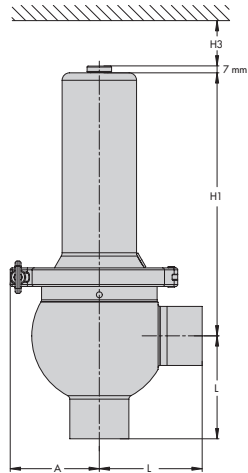
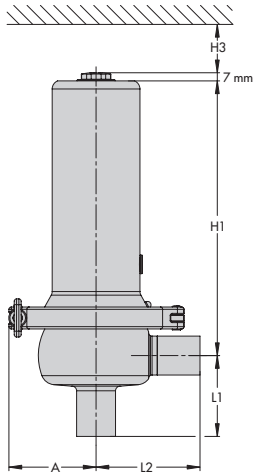

The clamp fitting is turned 90° in the drawing.

Type 2371-01 · DN 15 to 25 · NPS ½ to 1

Type 2371-01 · DN 32 to 50 · NPS 1¼ to 2

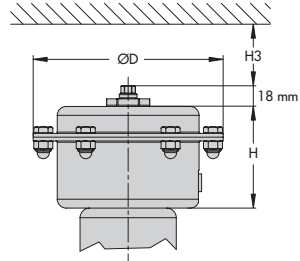
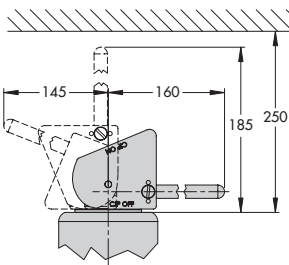

Type 2371-01 · With manual stem locking

Type 2371-01 · With pneumatic stem locking

The dimensions of the regulator are listed in Table 2 on page 31.

Type 2371-01 with welding ends is shown in these drawings.

The dimensions of the stem locking are the same for all versions and valve sizes of the regulators.

Fig. 15: Dimensional drawings for Type 2371-01

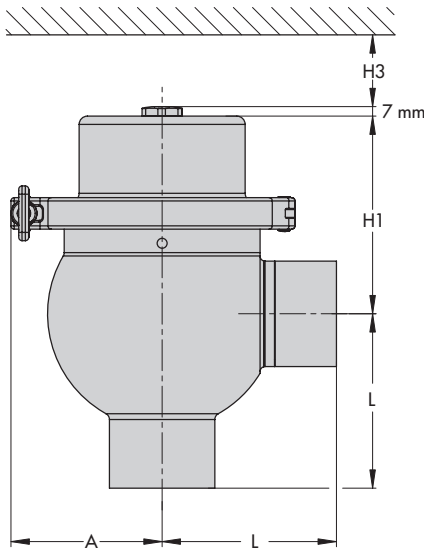

The clamp fitting is turned 90° in the drawing.

Type 2371-00 · DN 15 to 25 · NPS ½ to 1 · With welding ends

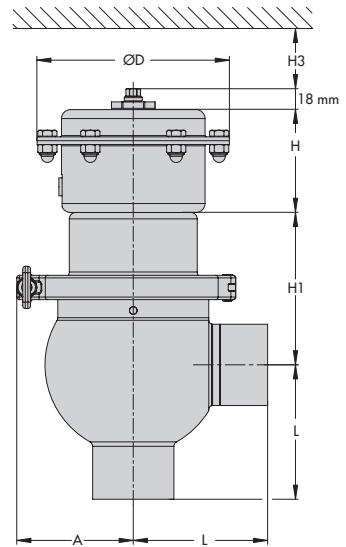

Type 2371-00 · DN 32 to 50 · NPS 1¼ to 2 · With pneumatic stem locking · With welding ends

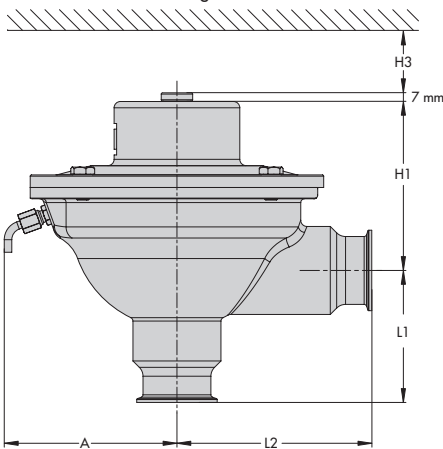

Type 2371-00 · DN 32 to 50, K_{VS} 25 · NPS 1¼ to 2, C_v 30 · Without stem locking · With clamp connections

The dimensions of the regulator are listed in Table 2 on page 31.

The dimensions of the stem locking are the same for all versions and valve sizes of the regulators.

Fig. 16: Dimensional drawings for Type 2371-00

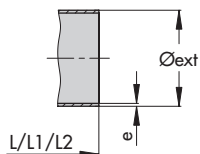

Welding ends

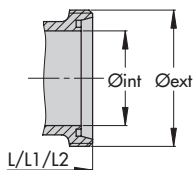

Threaded connections

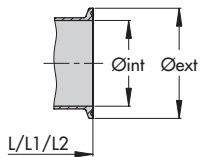

Clamp connections

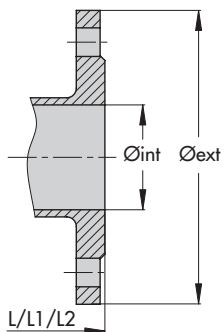

Flanges

Fig. 17: Dimensional drawings · Various types of end connection for Type 2371-00/-01 (see Table 3, Table 4, Table 5, and Table 6)

Table 2: Dimensions of the regulator · General dimensions (see section 10 on page 28)

Type 2371-00 and Type 2371-01							Type 2371-00 (K _{vS} /C _v 25/30)			
Valve size	DN 15 NPS ½	DN 20 NPS ¾	DN 25 NPS 1	DN 32 NPS 1¼	DN 40 NPS 1½	DN 50 NPS 2	DN 32 NPS 1¼	DN 40 NPS 1½	DN 50 NPS 2	
Common dimensions	A (Type 2371-00)	70 mm		100 mm			145 mm			
	A (Type 2371-01)	85 mm		100 mm			–			
	H	80 mm								
	H1 (Type 2371-00)	80 mm		120 mm			135 mm			
	H1 (Type 2371-01)	240 mm		290 mm			–			
	H3	≥200 mm								
	ØD	150 mm								
	Weight, approx.									
Type 2371-00	3 kg		11 kg			15 kg				
Type 2371-01	8.5 kg		12 kg			–				
Stem locking										
Additional pneumatic actuator					2.5 kg					
Manual stem locking					0.7 kg					

Table 3: Threaded connections

Valve size		Type 2371-00 and Type 2371-01						Type 2371-00 (K _{vs} /C _v 25/30)		
		DN 15 NPS ½	DN 20 NPS ¾	DN 25 NPS 1	DN 32 NPS 1¼	DN 40 NPS 1½	DN 50 NPS 2	DN 32 NPS 1¼	DN 40 NPS 1½	DN 50 NPS 2
DIN 11864-1 GS Form A Series A	P _{max}	10 bar/150 psi								
	L	64	64	64	100	100	100	–	–	–
	L1	60	60	60	100	100	100	105	105	105
	L2	90	90	90	100	100	100	155	155	155
	Ø _{int}	16	20	26	32	38	50	32	38	50
	Ø _{ext}	RD34x1/8"	RD44x1/6"	RD52x1/6"	RD58x1/6"	RD65x1/6"	RD78x1/6"	RD58x1/6"	RD65x1/6"	RD78x1/6"
DIN 11864-1 GS Form A Series B	P _{max}	10 bar/150 psi								
	L	64	64	64	100	100	100	–	–	–
	L1	60	60	60	100	100	100	105	105	105
	L2	90	90	90	100	100	100	155	155	155
	Ø _{int}	18.1	23.7	29.7	38.4	44.3	56.3	38.4	44.3	56.3
	Ø _{ext}	RD44x1/6"	RD52x1/6"	RD58x1/6"	RD65x1/6"	RD78x1/6"	RD95x1/6"	RD65x1/6"	RD78x1/6"	RD95x1/6"
DIN 11864-1 GS Form A Series C	P _{max}	10 bar/150 psi								
	L	64	64	64	–	100	100	–	–	–
	L1	60	60	60	–	100	100	–	105	105
	L2	90	90	90	–	100	100	–	155	155
	Ø _{int}	9.4	15.75	22.1	–	34.8	47.5	–	34.8	47.5
	Ø _{ext}	RD28x1/8"	RD34x1/8"	RD52x1/6"	–	RD65x1/6"	RD78x1/6"	–	RD65x1/6"	RD78x1/6"
DIN 11887 A Series 1	P _{max}	10 bar/150 psi								
	L	64	64	64	100	100	100	–	–	–
	L1	60	60	60	100	100	100	105	105	105
	L2	90	90	90	100	100	100	155	155	155
	Ø _{int}	16	20	26	32	38	50	32	38	50
	Ø _{ext}	RD34x1/8"	RD44x1/6"	RD52x1/6"	RD58x1/6"	RD65x1/6"	RD78x1/6"	RD58x1/6"	RD65x1/6"	RD78x1/6"
ISO 2853 = IDF	P _{max}	10 bar/150 psi								
	L	–	–	64	100	100	100	–	–	–
	L1	–	–	60	100	100	100	105	105	105
	L2	–	–	90	100	100	100	155	155	155
	Ø _{int}	–	–	22.6	31.3	35.6	48.6	31.3	35.6	48.6
	Ø _{ext}	–	–	37x1/8"	45.9x1/8"	50.6x1/8"	64.1x1/8"	45.9x1/8"	50.6x1/8"	64.1x1/8"
SMS 1146	P _{max}	10 bar/150 psi								
	L	–	–	55	105	105	105	–	–	–
	L1	–	–	60	105	105	105	105	105	105
	L2	–	–	90	105	105	105	155	155	155
	Ø _{int}	–	–	22.6	29.6	35.6	48.6	29.6	35.6	48.6
	Ø _{ext}	–	–	RD40x1/6"	RD48x1/6"	RD60x1/6"	RD70x1/6"	RD48x1/6"	RD60x1/6"	RD70x1/6"

Table 4: Clamp connections

Valve size		Type 2371-00 and Type 2371-01						Type 2371-00 (K _V /C _V 25/30)		
		DN 15 NPS ½	DN 20 NPS ¾	DN 25 NPS 1	DN 32 NPS 1¼	DN 40 NPS 1½	DN 50 NPS 2	DN 32 NPS 1¼	DN 40 NPS 1½	DN 50 NPS 2
DIN 11864-3 NKS Form A Series A	p _{max}	10 bar/150 psi								
	L	60.3	60.3	60.3	88.9	88.9	88.9	–	–	–
	L1	60	60	60	88.9	88.9	88.9	105	105	105
	L2	90	90	90	88.9	88.9	88.9	155	155	155
	∅ _{int}	16	20	26	32	38	50	32	38	50
	∅ _{ext}	34	50.5	50.5	50.5	64	77.5	50.5	64	77.5
DIN 11864-3 NKS Form A Series B	p _{max}	10 bar/150 psi								
	L	60.3	60.3	60.3	88.9	88.9	88.9	–	–	–
	L1	60	60	60	88.9	88.9	88.9	105	105	105
	L2	90	90	90	88.9	88.9	88.9	155	155	155
	∅ _{int}	18.1	23.7	29.7	38.4	44.3	56.3	38.4	44.3	56.3
	∅ _{ext}	34	50.5	50.5	64	64	91	64	64	91
DIN 11864-3 NKS Form A Series C	p _{max}	10 bar/150 psi								
	L	60.3	60.3	60.3	–	88.9	88.9	–	–	–
	L1	60	60	60	–	88.9	88.9	–	105	105
	L2	90	90	90	–	88.9	88.9	–	155	155
	∅ _{int}	9.4	15.75	22.1	–	34.8	47.5	–	34.8	47.5
	∅ _{ext}	34	34	50.5	–	64	77.5	–	64	77.5
DIN 32676, Series A	p _{max}	10 bar/150 psi								
	L	60.3	60.3	60.3	88.9	88.9	88.9	–	–	–
	L1	60	60	60	88.9	88.9	88.9	105	105	105
	L2	90	90	90	88.9	88.9	88.9	155	155	155
	∅ _{int}	16	20	26	32	38	50	32	38	50
	∅ _{ext}	34	34	50.5	50.5	50.5	64	50.5	50.5	64
DIN 32676 Series B	p _{max}	10 bar/150 psi								
	L	60.3	60.3	60.3	88.9	88.9	88.9	–	–	–
	L1	60	60	60	88.9	88.9	88.9	105	105	105
	L2	90	90	90	88.9	88.9	88.9	155	155	155
	∅ _{int}	18.1	23.7	29.7	38.4	44.3	56.3	38.4	44.3	56.3
	∅ _{ext}	50.5	50.5	50.5	64	64	77.5	64	64	77.5
DIN 32676 Series C	p _{max}	10 bar/150 psi								
	L	60.3	60.3	60.3	–	88.9	88.9	–	–	–
	L1	60	60	60	–	88.9	88.9	–	105	105
	L2	90	90	90	–	88.9	88.9	–	155	155
	∅ _{int}	9.4	15.75	22.1	–	34.8	47.5	–	34.8	47.5
	∅ _{ext}	25	25	50.5	–	50.5	64	–	50.5	64
ISO 2852	p _{max}	10 bar/150 psi								
	L	–	–	60.3	88.9	88.9	88.9	–	–	–
	L1	–	–	60	88.9	88.9	88.9	105	105	105
	L2	–	–	90	88.9	88.9	88.9	155	155	155
	∅ _{int}	–	–	22.6	31.3	35.6	48.6	31.3	35.6	48.6
	∅ _{ext}	–	–	50.5	50.5	50.5	64	50.5	50.5	64
BS 4825 Part 3 = ASME BPE	p _{max}	10 bar/150 psi								
	L	60.3 ¹⁾	60.3 ¹⁾	60.3	–	88.9	88.9	–	–	–
	L1	60 ¹⁾	60 ¹⁾	60	–	88.9	88.9	–	105	105
	L2	90 ¹⁾	90 ¹⁾	90	–	88.9	88.9	–	155	155
	∅ _{int}	9.4 ¹⁾	15.75 ¹⁾	22.2	–	34.9	47.6	–	34.9	47.6
	∅ _{ext}	25 ¹⁾	25 ¹⁾	50.5	–	50.5	64	–	50.5	64

¹⁾ Version according to ASME BPE only

Table 5: Welding ends

Valve size		Type 2371-00 and Type 2371-01						Type 2371-00 (K _{vS} /C _v 25/30)		
		DN 15 NPS ½	DN 20 NPS ¾	DN 25 NPS 1	DN 32 NPS 1¼	DN 40 NPS 1½	DN 50 NPS 2	DN 32 NPS 1¼	DN 40 NPS 1½	DN 50 NPS 2
DIN 11866 Series A = DIN 11850 Series 2	p _{max}	10 bar/150 psi								
	L	70	70	70	105	105	105	–	–	–
	L1	70	70	70	105	105	105	105	105	105
	L2	90	90	90	105	105	105	155	155	155
	Ø _{ext}	19	23	29	35	41	53	35	41	53
	e	1.5	1.5	1.5	1.5	1.5	1.5	1.5	1.5	1.5
DIN 11866 Series B	p _{max}	10 bar/150 psi								
	L	70	70	70	105	105	105	–	–	–
	L1	70	70	70	105	105	105	105	105	105
	L2	90	90	90	105	105	105	155	155	155
	Ø _{ext}	21.3	26.9	33.7	42.4	48.3	60.3	42.4	48.3	60.3
	e	1.6	1.6	2	2	2	2	2	2	2
DIN 11866 Series C = ASME-BPE 2007 = ASTM A-270 = BS 4825	p _{max}	10 bar/150 psi								
	L	70	70	70	–	105	105	–	–	–
	L1	70	70	70	–	105	105	–	105	105
	L2	90	90	90	–	105	105	–	155	155
	Ø _{ext}	12.7	19.05	25.4	–	38.1	50.8	–	38.1	50.8
	e	1.65 ⁺⁰ _{-0.1}	1.65 ⁺⁰ _{-0.1}	1.65 ⁺⁰ _{-0.1}	–	1.65 ⁺⁰ _{-0.1}	1.65 ⁺⁰ _{-0.1}	–	1.65 ⁺⁰ _{-0.1}	1.65 ⁺⁰ _{-0.1}
DIN EN ISO 1127 Series 1	p _{max}	10 bar/150 psi								
	L	70	70	70	105	105	105	–	–	–
	L1	70	70	70	105	105	105	105	105	105
	L2	90	90	90	105	105	105	155	155	155
	Ø _{ext}	21.3	26.9	33.7	42.4	48.3	60.3	42.4	48.3	60.3
	e	1.6	1.6	2	2	2	2.6	2	2	2.6
ISO 2037	p _{max}	10 bar/150 psi								
	L	70	70	70	105	105	105	–	–	–
	L1	70	70	70	105	105	105	105	105	105
	L2	90	90	90	105	105	105	155	155	155
	Ø _{ext}	17.2	21.3	25	33.7	38	51	33.7	38	51
	e	1	1	1.2	1.2	1.2	1.2	1.2	1.2	1.2
SMS 3008 = NF A 49-249	p _{max}	10 bar/150 psi								
	L	–	–	70	105	105	105	–	–	–
	L1	–	–	70	105	105	105	105	105	105
	L2	–	–	90	105	105	105	155	155	155
	Ø _{ext}	–	–	25	33.7	38	51	33.7	38	51
	e	–	–	1.2	1.2	1.2	1.2	1.2	1.2	1.2

Table 6: Flanges

Valve size		Type 2371-00 and Type 2371-01						Type 2371-00 (K_{VS}/C_V 25/30)		
		DN 15 NPS 1/2	DN 20 NPS 3/4	DN 25 NPS 1	DN 32 NPS 1 1/4	DN 40 NPS 1 1/2	DN 50 NPS 2	DN 32 NPS 1 1/4	DN 40 NPS 1 1/2	DN 50 NPS 2
DIN 11864-2 NF Form A Series A	P_{max}	10 bar/150 psi								
	L	90	95	100	105	115	125	–	–	–
	L1	90	95	100	105	115	125	105	105	105
	L2	90	95	100	105	115	125	155	155	155
	\varnothing_{int}	16	20	26	32	38	50	32	38	50
	\varnothing_{ext}	59	64	70	76	82	94	76	82	94
DIN 11864-2 NF Form A Series B	P_{max}	10 bar/150 psi								
	L	90	95	100	105	115	125	–	–	–
	L1	90	95	100	105	115	125	105	105	105
	L2	90	95	100	105	115	125	155	155	155
	\varnothing_{int}	18.1	23.7	29.7	38.4	44.3	56.3	38.4	44.3	56.3
	\varnothing_{ext}	62	69	74	82	88	103	82	88	103
DIN 11864-2 NF Form A Series C	P_{max}	10 bar/150 psi								
	L	90	90	100	–	115	125	–	–	–
	L1	90	90	100	–	115	125	–	105	105
	L2	90	90	100	–	115	125	–	155	155
	\varnothing_{int}	9.4	15.75	22.1	–	34.8	47.5	–	34.8	47.5
	\varnothing_{ext}	54	59	66	–	79	92	–	79	92
DIN EN 1092-1 B2 or ASME B16.5 Cl 150	On request									



SAMSON AG · MESS- UND REGELTECHNIK
Weismüllerstraße 3 · 60314 Frankfurt am Main, Germany
Phone: +49 69 4009-0 · Fax: +49 69 4009-1507
samson@samson.de · www.samson.de

EB 2642 EN

2016-03-21 · English