

Series 45 Self-operated Regulators



Type 45-9 Flow Regulator



Type 45-9 Flow Regulator

Mounting and Operating Instructions

EB 3128 EN

Edition March 2016



Note on these mounting and operating instructions

These mounting and operating instructions assist you in mounting and operating the device safely. The instructions are binding for handling SAMSON devices.

- For the safe and proper use of these instructions, read them carefully and keep them for later reference.
- If you have any questions about these instructions, contact SAMSON's After-sales Service Department (aftersaleservice@samson.de).



The mounting and operating instructions for the devices are included in the scope of delivery. The latest documentation is available on our website (www.samson.de) > Product documentation. You can enter the document number or type number in the [Find:] field to look for a document.

Definition of signal words



DANGER!

Hazardous situations which, if not avoided, will result in death or serious injury



NOTICE

Property damage message or malfunction



WARNING!

Hazardous situations which, if not avoided, could result in death or serious injury



Note:

Additional information



Tip:

Recommended action

1	General safety instructions	4
2	Process medium and scope of application	5
3	Transportation and storage	5
4	Design and principle of operation	6
5	Installation	8
5.1	Mounting position	8
5.2	Pressure gauge	8
5.3	Strainer (filter).....	8
5.4	Shut-off valve.....	8
6	Operation	9
6.1	Start-up.....	9
6.2	Adjusting the set point	9
7	Maintenance · Replacing parts	12
7.1	Cleaning or replacing the plug.....	13
7.2	Replacing the diaphragm	13
8	Customer inquiries	15
9	Nameplate	16
10	Technical data	17
11	Dimensions and weights	18

1 General safety instructions

- All safety instructions and warnings given in these mounting and operating instructions, particularly those concerning installation, start-up and maintenance, must be strictly observed.
- The device must be mounted, started up or serviced by fully trained and qualified personnel only; the accepted industry codes and practices are to be observed. Make sure employees or third persons are not exposed to any danger.
- According to these mounting and operating instructions, trained personnel refers to individuals who are able to judge the work they are assigned to and recognize possible dangers due to their specialized training, their knowledge and experience as well as their knowledge of the applicable standards.
- The devices comply with the requirements of the European Pressure Equipment Directive 97/23/EC. Devices with a CE marking have a declaration of conformity, which includes information about the applied conformity assessment procedure. This declaration of conformity can be provided on request.
- To ensure appropriate use, only use the device in applications where the operating pressure and temperatures do not exceed the specifications used for sizing the device at the ordering stage.
- The manufacturer does not assume any responsibility for damage caused by external forces or any other external factors.
- Any hazards that could be caused in the regulator by the process medium, operating pressure or by moving parts are to be prevented by taking appropriate precautions.
- Proper transport, storage, installation, operation and maintenance are assumed.



Note:

Non-electric valve versions whose bodies are not lined with an insulating material coating do not have their own potential ignition source according to the risk assessment stipulated in EN 13463-1: 2009, section 5.2, even in the rare incident of an operating fault. Therefore, such valve versions do not fall within the scope of Directive 94/9/EC.

For connection to the equipotential bonding system, observe the requirements specified in section 6.3 of EN 60079-14: 2011 (VDE 0165 Part 1).

2 Process medium and scope of application

Flow regulator for district heating supply networks, large pipeline systems and industrial plants · Differential pressure across the restriction $\Delta p_{\text{restriction}}$ **0.2** or **0.3 bar** · Nominal size **DN 15 to 50** · Nominal pressure **PN 16** or **PN 25** · Suitable for liquids up to **150 °C**, air and nitrogen up to **150 °C** ¹⁾

The valve closes when the flow rate rises

¹⁾ Diaphragm and seals made of FPM (FKM) and PN 25 version

3 Transportation and storage

The regulator must be carefully handled, transported and stored. Protect the regulator against adverse influences, such as dirt, moisture or frost, during storage and transportation.

4 Design and principle of operation

See Fig. 1 on page 7.

Valve made of red brass with welding ends (special versions with threaded ends or screwed-on flanges)

Nominal sizes DN 32, 40 and 50 also available with flanged valve body made of spheroidal graphite iron.

The flow regulator basically consists of a valve with restriction, seat and plug as well as a closing actuator with an operating diaphragm.

The regulator is designed to maintain the flow rate at the adjusted set point in heating and district heating systems.

The medium flows through the valve in the direction indicated by the arrow on the valve body. The flow rate depends on the area released by the valve plug (3) and the adjustable restriction (1.2). The integral spring (5) determines the differential pressure across the restriction (0.2 or 0.3 bar).

The high pressure upstream of the restriction (1.2) is transmitted to the high-pressure side of the diaphragm actuator through the attached control line (11).

The low pressure downstream of the restriction acts on the low-pressure side of the operating diaphragm (6.1) through a hole in the valve plug.

The differential pressure generated at the restriction is converted into a positioning force by the operating diaphragm. This force is used to move the valve plug depending on the force of the set point springs (5).

Table 1: Tightening torques in Nm

Nominal size	Guide nipple (3)	Screws (6.2)	Restriction (1.2)
DN 15 to 25	70 Nm	8 Nm	70 Nm
DN 32	110 Nm	8 Nm	110 Nm
DN 40, 50	110 Nm	18 Nm	110 Nm

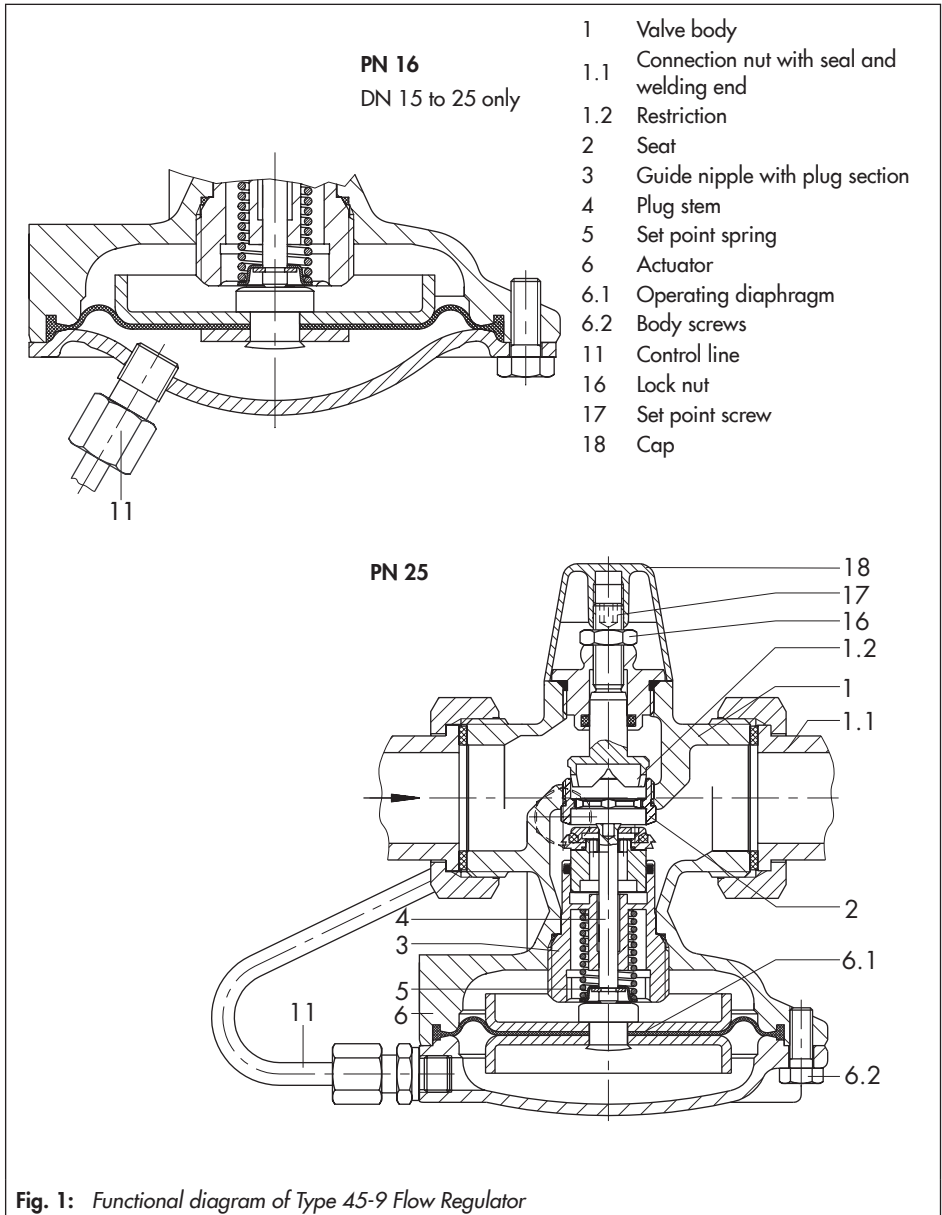

Fig. 1: Functional diagram of Type 45-9 Flow Regulator

5 Installation

5.1 Mounting position

See Fig. 1 on page 7.

Standard installation · Install the regulators in **horizontal** pipelines with the actuator facing down.



NOTICE

*Incorrectly installed regulator
The regulator can be damaged.
Make sure the regulator is installed
free of stress. Observe permissible
mounting position.*



NOTICE

*Possible malfunction and damage
due to adverse effects of weather
conditions (temperature, humidity).
Do not install the regulator outdoors
or in rooms prone to frost. If such a
location cannot be avoided, protect
the regulator against freezing up if
the process medium flowing through
the valve can freeze up. Either heat
the regulator or remove it from the
plant and completely drain the resid-
ual medium.*

The regulator in nominal sizes **DN 15 to 25** can also be installed in vertical pipes.

The following generally applies:

- Choose a place of installation that allows you to freely access the regulator even after the entire plant has been completed.
- Install a strainer (e.g. SAMSON Type 1 NI) upstream of the regulator (see section 5.3).
- The direction of flow must match the direction indicated by the arrow on the body.
- Make sure the regulator is installed free of stress.

5.2 Pressure gauge

Install a pressure gauge at a suitable point to monitor the pressures prevailing in the plant.

5.3 Strainer (filter)

A strainer installed upstream in the flow pipe holds back any dirt or other foreign particles. For example, the SAMSON Type 1 NI Strainer is suitable (▶ T 1010).

- Install the strainer upstream of the regulator.
- The direction of flow must correspond to the arrow on the body.
- The filter element must be installed to hang downwards.
- Remember to leave enough space to remove the filter element.

5.4 Shut-off valve

Install a hand-operated shut-off valve both upstream of the strainer and at the outlet of the return flow pipe. This allows the plant to be shut down for cleaning and maintenance, and when the plant is not used for longer periods of time.

6 Operation

6.1 Start-up

See Fig. 1 on page 7.

- First start up the regulator after mounting all parts.
- Open the shut-off valves slowly preferably starting from the return flow pipe.
- Slowly fill the plant.



Note:

Before starting up or pressurizing the regulator, make sure the restriction (1.2) is open by turning the set point screw (17) counterclockwise (↺) as far as it will go.

Pressure testing of the plant · All plant components must be designed for the test pressure. Replace the regulator, if necessary.



NOTICE

Impermissible excessive pressure. The diaphragm actuator can be damaged.

*The pressure at the actuator must not exceed **the nominal pressure by 1.5 times** nor the maximum permissible differential pressure on testing the pressure of the plant when the regulator is already installed.*

6.2 Adjusting the set point

See Fig. 1 on page 7.

To adjust or change the flow rate set point, proceed as follows:

- Unscrew cap (18), undo the lock nut (16) and turn the set point screw (17):
- Turn clockwise ↻:
The restriction closes. The flow rate drops.
- Turn counterclockwise ↺:
The restriction opens. The flow rate rises.

The adjustment diagrams (Fig. 2 or Fig. 3) can be used as a guide to adjust the flow rate. The required number of turns of the set point screw (17) is based on a closed restriction (1.2).

Refer to the nameplate on the regulator or to Table 2 to find out the adjustable set point range of the relevant nominal size.

All flow rate curves refer to a differential pressure across the restriction of 0.2 bar, except for the dotted curve which refers to a differential pressure of 0.3 bar.

Different K_{VS} coefficients are available for valve size DN 15 to provide several flow set point ranges.

Retighten the lock nut and screw the cap (18) back on after the required flow rate is reached.

For the special version with a scaled cap, the set point can be adjusted directly using the scaled cap (one marked scale division corresponds to one turn of the set point screw).

Table 2: Flow rate set points in m³/h for water

Nominal size DN	DN 15				DN 20	DN 25	DN 32	DN 40 ¹⁾	DN 50 ¹⁾
K _{VS} coefficient	0.4 ²⁾	1 ²⁾	2.5 ²⁾	4	6.3	8	12.5	16/20 ³⁾	20/25 ³⁾
Flow rate set point range in m ³ /h at a diff. pressure across restriction	0.2 bar	0.01 to 0.2	0.12 to 0.64	0.2 to 1.2	0.1 to 2.5	0.1 to 3.6	0.1 to 4.2	0.3 to 10	0.4 to 12.5
	0.3 bar	–	–	–	0.1 to 3	–	0.1 to 5	–	–

¹⁾ Also as version with flanged valve body

²⁾ Special versions

³⁾ K_{VS} coefficient with flanged valve body

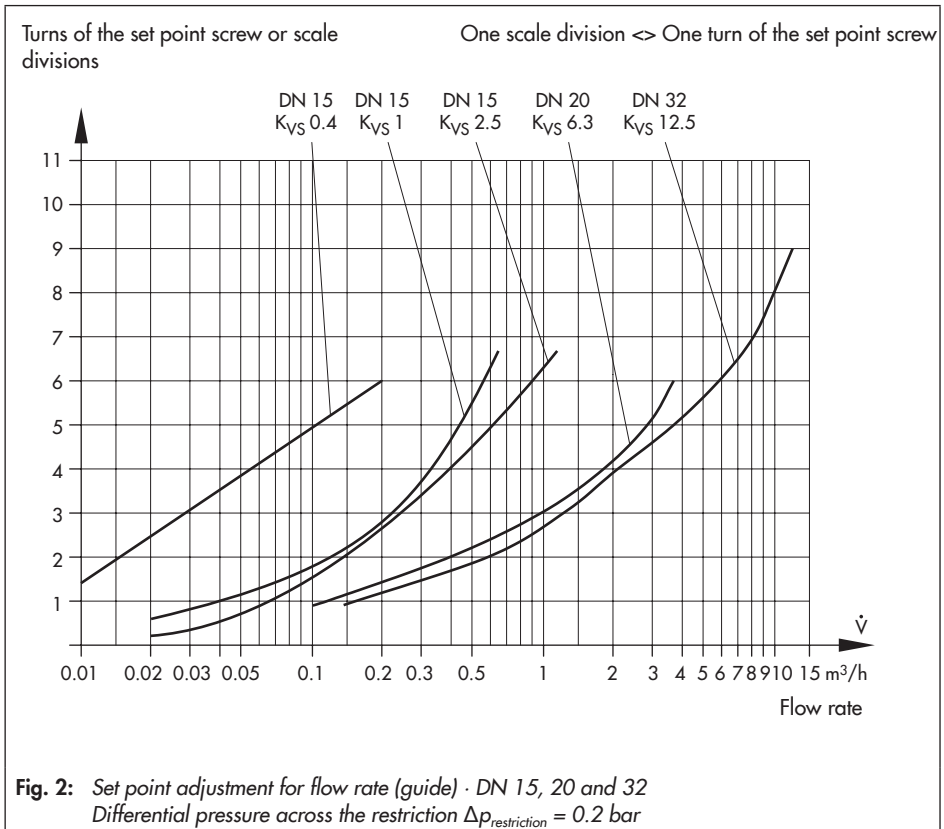

Type 45-9 Flow Regulator in special version with external scaled cap (five scale divisions) for adjustment of the flow rate set point



Fig. 4: Type 45-9 with scaled cap for set point adjustment

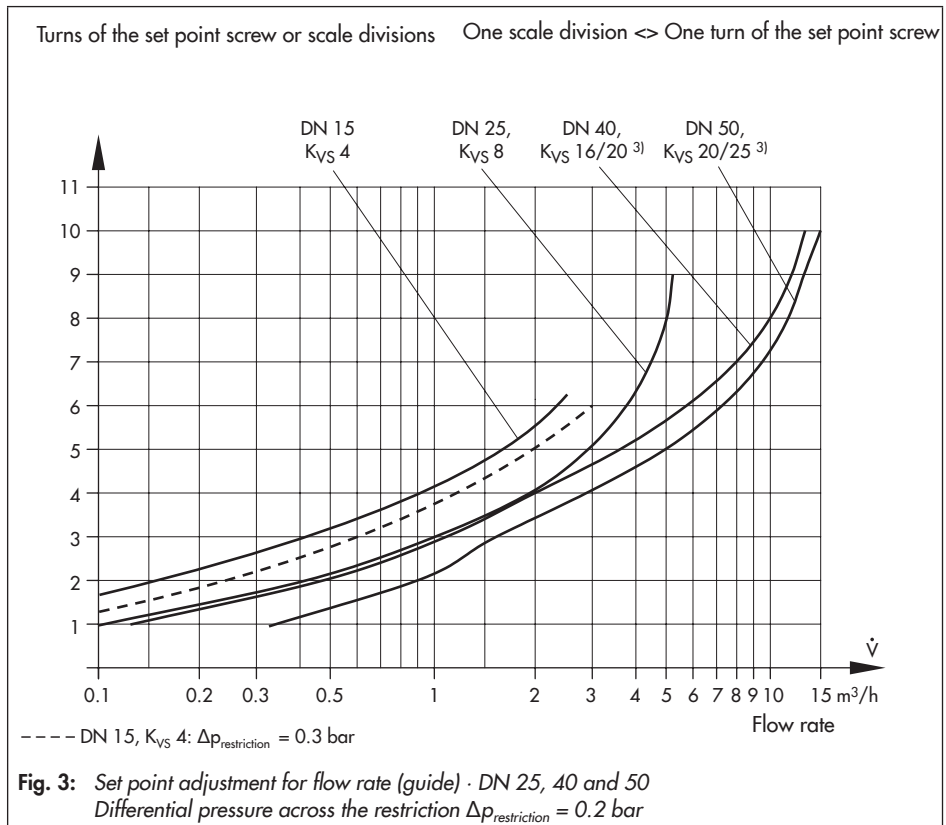

7 Maintenance · Replacing parts

The regulator does not require any maintenance. Nevertheless, it is subject to natural wear, particularly at the seat, plug and operating diaphragm. Depending on the operating conditions, check the regulator at regular intervals to avoid possible malfunctions.

If the valve does not close tightly, this may be caused by a dirty seat and plug or due to wear.

If the flow rate deviates considerably from the adjusted set point, e.g. rapidly increasing flow rate, check the operating diaphragm for ruptures and replace it, if necessary.

Before carrying out any maintenance work on the flow regulator, remove it from the pipeline. Depressurize the relevant plant section and drain it.

Details on faults and how to remedy them can be found in Table 3.

If faults cannot be remedied following the recommended action, contact SAMSON.



WARNING!

Before performing any work on the regulator, make sure the relevant plant section has been depressurized and, depending on the process medium, drained as well. We recommend removing the valve from the pipeline. When used at high temperatures, allow the plant section to cool down to ambient temperature. Disconnect or shut off the control line to prevent the risk of moving regulator parts. As valves are not free of cavities, remember that residual process medium might still be contained in the valve.

7.1 Cleaning or replacing the plug

See Fig. 1 on page 7.

1. Remove the device from the pipeline
2. Unscrew the control line (11).
3. Unscrew the screws (6.2). Remove the bottom diaphragm case together with the operating diaphragm (6.1) and diaphragm plate.
4. For valve sizes DN 15 to 25, unscrew and pull out the guide nipple with plug section (3) using a socket wrench (order no. 1280-3001).

For valve sizes DN 32 to 50, unscrew the stopper first and pull out the plug section.

5. Clean the seat and plug thoroughly.
Check the control line for any blockages.

If the plug is damaged, replace the entire plug section with a new one.

To reassemble, proceed in reverse order.



Note:

On reassembly, make sure that the diaphragm has been inserted properly into the ring groove before screwing back on the diaphragm case.

Observe tightening torques specified in Table 1 on page 6.

7.2 Replacing the diaphragm

See Fig. 1 on page 7.

1. Remove the device from the pipeline
2. Unscrew the control line (11).
3. Unscrew the screws (6.2). Remove the bottom diaphragm case together with the operating diaphragm (6.1) and diaphragm plate.
4. Replace the diaphragm together with the diaphragm plates with new ones.
5. To reassemble, proceed in reverse order.

Table 3: Troubleshooting

Malfunction	Possible reasons	Recommended action
Flow rate exceeds adjusted set point	Leak between seat and plug	Remove valve from the pipeline and clean seat and plug. Renew plug, if necessary (see section 7.1). If this is not possible, return regulator to SAMSON for repair.
	Defective operating diaphragm	Replace diaphragm (see section 7.2) or return regulator to SAMSON for repair.
	Control line blocked	Remove control line and clean it.
	Valve too large for control task	Recalculate K_{VS} and contact SAMSON for further action.
Flow set point not reached	Leak between seat and plug	Remove valve from the pipeline and clean seat and plug. Renew plug, if necessary (see section 7.1). If this is not possible, return regulator to SAMSON for repair.
	Incorrect set point range selected.	Check set point range and contact SAMSON for further action.
	Safety device, e.g. pressure limiter, has been triggered.	Check plant. Unlock safety device.
	Plant differential pressure too low	Compare differential pressure in the plant with the plant's drag.
	Strainer blocked	Drain and clean filter of the strainer.
	Incorrectly installed valve (direction of flow).	Install the valve in such a way that the flow of direction corresponds with the direction indicated by the arrow on the valve body.
Control loop hunts.	Valve too large for control task	Recalculate K_{VS} and contact SAMSON for further action.

8 Customer inquiries

Contact SAMSON's After-sales Service department for support concerning maintenance or repair work or when malfunctions or defects arise.

E-mail

You can reach the After-sales Service Department at aftersaleservice@samson.

Addresses of SAMSON AG and its subsidiaries

The addresses of SAMSON AG, its subsidiaries, representatives and service facilities worldwide can be found on the SAMSON website (► www.samson.de) in all SAMSON product catalogs or on the back of these Mounting and Operating Instructions.

To assist diagnosis and in case of an unclear mounting situation, specify the following details (so far as possible):

- Device type and nominal size
- Model number or configuration ID (Var.-ID)
- Threaded connection or flanges
- Upstream and downstream pressure
- Temperature and process medium
- Min. and max. flow rate
- Is a strainer installed?
- Installation drawing showing the exact location of the regulator and all the additionally installed components (shut-off valves, pressure gauge, etc.)

9 Nameplate

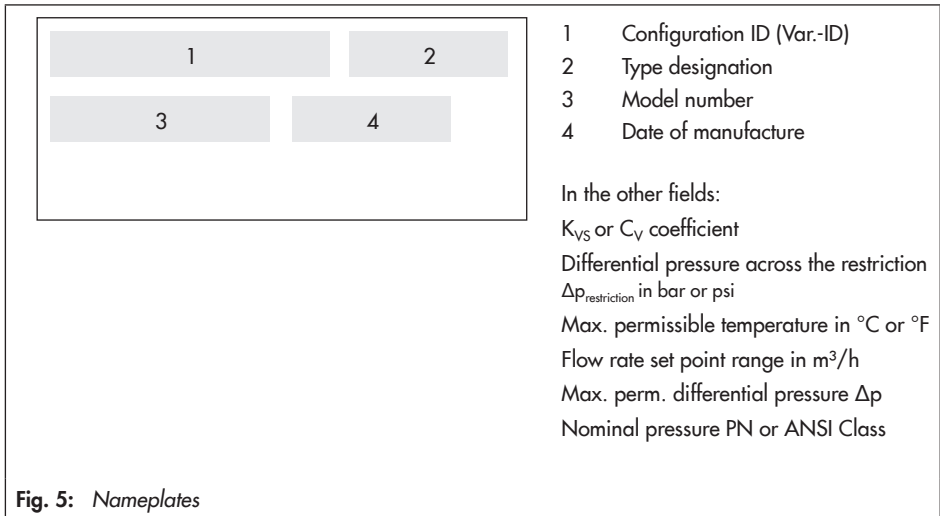

Note:

Conversion from chromate coating to iridescent passivation

We at SAMSON are converting the surface treatment of passivated steel parts in our production. As a result, you may receive a device assembled from parts that have been subjected to different surface treatment methods. This means that the surfaces of some parts show different reflections. Parts can have an iridescent yellow or silver color. This has no effect on corrosion protection.

For further information go to ► www.samson.de/chrome-en.html

10 Technical data

Nominal size	DN 15				DN 20	DN 25	DN 32 ²⁾	DN 40 ²⁾	DN 50 ²⁾
K _{VS} coefficient	0.4 ¹⁾	1 ¹⁾	2.5	4 ¹⁾	6.3	8	12.5	16	20
Flanged body	-						12.5	20	25
x _{FZ} value	0.6	0.6	0.6	0.6	0.6	0.55	0.5	0.5	0.45
Flanged body	-						0.45	0.45	0.40
Nominal pressure PN	16/25	16/25	16/25	16/25	16/25	16/25	25	25	25
Max. permissible differential pressure Δp across the valve	10 ³⁾ /20 bar						16 bar		
Max. permissible temperature	Liquids: 130 °C (PN 16)/150 °F (PN 25) · Nitrogen and air: 150 °C ⁴⁾								
Compliance	CE EAC								

1) Special versions

2) Additional version: Valve with flanged body made of spheroidal graphite iron (EN-JS1049)

3) For PN 16 version

4) Only in PN 25 version and diaphragm and seals made of FPM (FKM)

The minimum required differential pressure Δp_{min} across the valve is calculated as follows:

$$\Delta p_{\min} = \Delta p_{\text{restriction}} + \left(\frac{V}{K_{VS}} \right)^2$$

Δp_{min} Minimum differential pressure across the valve in bar

Δp_{restriction} Differential pressure created at the restriction for measuring the flow rate

V̇ Adjusted flow rate in m³/h

K_{VS} Valve flow coefficient in m³/h

11 Dimensions and weights

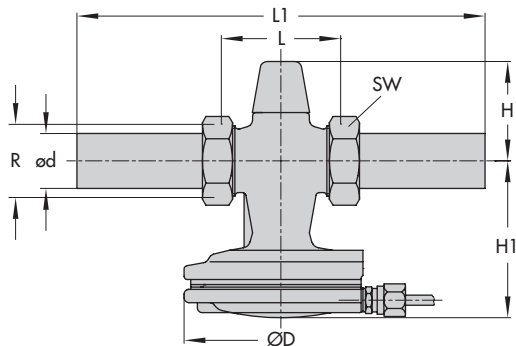

Red brass valve with welding ends (standard version)

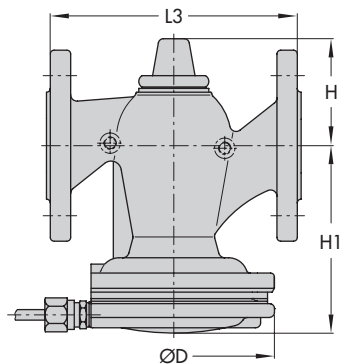

Valve made of spheroidal graphite iron with flanges (DN 32, 40 and 50)

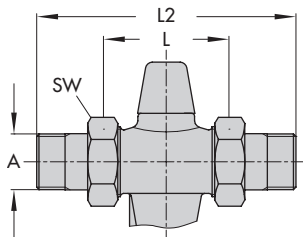

With threaded ends

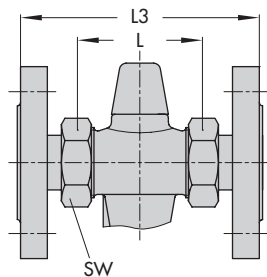

With screw-on flanges

Fig. 6: Dimensional drawings

Table 4: Regulator *with* connecting parts · Dimensions in mm and weights in kg

Valve size	DN 15	DN 20	DN 25	DN 32	DN 40	DN 50
With welding ends						
Length L1	210	234	244	268	294	330
Weight, approx. kg	1.6	1.7	1.8	3	5.5	6
With threaded ends						
Length L2	129	144	159	192	206	228
Male thread A	G 1½	G ¾	G 1	G 1¼	G 1½	G 2
Weight, approx. kg	1.6	1.7	1.8	3	5.5	6
With flanges ^{1) 2)} or with flanged body (DN 32 to 50)						
Length L3	130	150	160	180	200	230
Weight, approx. kg	3	3.7	4.3	6.2	9.5	11

¹⁾ PN 16/25

²⁾ Flanges are already mounted on valves in DN 40 and 50

The dimensions and weights of valves with flanged bodies (DN 32, 40 and 50) are the same as valves with screwed-on flanges.

Table 5: Regulators *without* connecting parts · Dimensions in mm

Valve size	DN 15	DN 20	DN 25	DN 32	DN 40	DN 50
Connecting thread R	G ¾	G 1	G 1¼	G 1¾	G 2	G 2½
Pipe Ød	21.3	26.8	32.7	42	48	60
Width across flats SW	30	36	46	59	65	82
Length L	65	70	75	100	110	130
H	65	65	65	85	85	85
H1	85	85	85	105	140	140
ØD	116	116	116	116	160	160



SAMSON AG · MESS- UND REGELTECHNIK
Weismüllerstraße 3 · 60314 Frankfurt am Main, Germany
Phone: +49 69 4009-0 · Fax: +49 69 4009-1507
samson@samson.de · www.samson.de

EB 3128 EN

2016-04-29 · English