

**Automation System TROVIS 5500  
Programmable Logic Controller (PLC)  
TROVIS 5571**



**Mounting and  
Operating Instructions**

**EB 5571 EN**

Firmware version 1.0x

Edition August 2006



### Disclaimer of liability

We are constantly developing our products and therefore, reserve the right to change the product or the information contained in this document at any time without notice.

We do not assume any liability for the accuracy or completeness of these mounting and operating instructions. Moreover, we do not guarantee that the buyer can use the product for an intended purpose. SAMSON rejects any liability for claims by the buyer, especially claims for compensation including lost profits or any other financial loss, except the damage was caused intentionally or by gross negligence. If an essential term of the contract is breached by negligence, SAMSON's liability is limited to the foreseeable damage.

### Safety instructions



- ▶ The device may only be assembled, started up or operated by trained and experienced personnel familiar with the product. Proper shipping and appropriate storage are assumed.
- ▶ The device has been designed for use in electrical power systems. For wiring and maintenance, you are required to observe the relevant safety regulations.

## Contents

<b>1</b>	<b>Operation</b>	<b>4</b>
1.1	Operating elements	4
1.1.1	Operating keys	4
1.2	Display	5
1.2.1	Adjusting the contrast of the display	6
1.3	Displaying data	7
1.4	Setting the system time	8
<b>2</b>	<b>Start-up</b>	<b>10</b>
2.1	Programming	10
2.2	Changing PLC settings	11
2.3	Configuring universal inputs	13
2.4	Resetting to default values	15
<b>3</b>	<b>Manual operation</b>	<b>16</b>
<b>4</b>	<b>Operational faults</b>	<b>17</b>
<b>5</b>	<b>Communication</b>	<b>18</b>
5.1	Modbus slave interface	18
5.2	Modbus master interface	20
5.3	Description of communication parameters to be adjusted	21
5.4	Meter bus interface	23
5.4.1	Activating the meter bus	23
<b>6</b>	<b>Installation</b>	<b>26</b>
<b>7</b>	<b>Electrical connection</b>	<b>28</b>
<b>8</b>	<b>Appendix</b>	<b>31</b>
8.1	Setting level	31
8.2	Sensor resistance tables	33
8.3	Technical data	34
8.4	Customer data	36
	Index	38

## 1 Operation

The programmable logic controller (PLC) is freely programmable. The controller is delivered **without** an executable program in the memory. The program must be developed separately for the desired purpose on a personal computer using ISaGRAF® (programming as in IEC 61131-1) and then transferred to the controller.

On start-up, after transferring the generated program, the **current time and date** must be set in the controller (-> section 1.4).

### 1.1 Operating elements

#### 1.1.1 Operating keys

The keys are located in the front panel of the PLC and protected by a Plexiglas door.



#### **Changeover key**

(press with pen or other pointed item)

Switch between levels (after entering the key number)



#### **Reset key**

(press with pen or other pointed item)

Reset freely accessible parameters and function blocks to their default values (factory settings)



#### **Cursor key(s)**

⬆️⬇️ Pressing both keys together:

- Switch to information level

⬇️ Pressing one of the keys separately:

- Navigate in levels (also in the program developed with ISaGRAF®)

- Set data points



#### **Enter key**

- Open levels (also in the program developed with ISaGRAF®)

- Activate editing mode for parameters and function blocks

- Confirm entered settings

## 1.2 Display

The programmable logic controller has a **plain text display**.

The display is automatically illuminated when entering or setting the controller.

After connecting the controller to the power supply, "System wird initialisiert..." (System is being initialized) appears briefly on the display.













Should the display not be illuminated or the contrast is too strong/weak, you can adapt the display illumination. Refer to section 1.2.1.

28.11.2005 10:00:05 V1.0x
Anwendung: ...
Version: ...
Datum: ...
CRC: ...
Größe: ... kB
Zykluszeit: ... ms

**If a program is not saved on the PLC**, the normal display (left) contains the date, time and current firmware version .

**If a program is saved on the PLC**, the normal display contains program-related information.

The current status of the three communication interfaces "RS-232/Slave", "RS-485/Master" and "RS-232/Prog" appears at the bottom of the display:

RS-232/Slave (left icon)		RS-485/Master (middle icon)		RS-232/Prog (right icon)	
	Interface inactive		Interface inactive		Interface inactive
	Direct connection to control station active		Modbus master active		Connection to ISaGRAF® Workbench active
	Modem inactive				
	Modem initialization active				
	RING, calling active				
	Connection established/canceled				
	Connection to control station active				
	Error				

### Note!

If no key is pressed for two minutes, the PLC returns to the normal display. The background illumination of the display is switched off automatically.

Any settings that have not been confirmed are not saved and must be re-entered.

### 1.2.1 Adjusting the contrast of the display

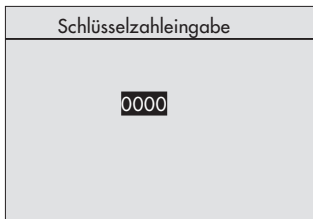

Activate the editing mode.

Display: Schlüsselzahleingabe (key number entry)

**0000** blinks



Confirm the **0000** reading.



Set the contrast.



Confirm the changed setting.

Display: Normal display (depending on the program)

### 1.3 Displaying data

The states of the inputs and outputs as well as information on the connected meter bus instruments can be retrieved in the information level. In addition, the analog and binary outputs can be changed (refer to section 3 on manual operation).

The information level is divided into individual menu items:

- ▶ **Analogeingänge (Analog inputs)** · Measured data from connected sensors
- ▶ **Analogausgänge (Analog outputs)** · Output data from four analog outputs \*)
- ▶ **Binäreingänge (Binary inputs)** · States of the binary sensors (on/off)
- ▶ **Binärausgänge (Binary outputs)** · States of the binary outputs (on/off) \*)
- ▶ **Zählerbus (Meter bus)** · Output data of the meters connected over meter bus

\*) The analog and binary output settings can be changed after entering the key number.

Proceed as follows:

Informationsebene
<b>Analogeingänge</b>
Analogausgänge
Binäreingänge
Binärausgänge
Zählerbus
Systeminfo
<i>Zurück</i>

- Switch to the information level.  
Display: Informationsebene (Information level)  
The menu item "Analogeingänge" is highlighted.
- Select required menu item, e.g. binary outputs.
- Activate the menu item.
- Select required data point.

Binärausgänge
BA07=AUS
BA08=AUS
BA09=AUS
BA10=AUS
BA11=AUS
BA12=AUS
<b><i>Zurück</i></b>

#### Returning to the information level

- Select *Zurück* (back) to return to the information level.
- Exit the menu item.  
Display: Informationsebene (Information level)

Informationsebene
Analogeingänge
Analogausgänge
Binäreingänge
Binärausgänge
Zählerbus
Systeminfo
<b><i>Zurück</i></b>

#### Exiting the information level

- Select *Zurück* (back).
- Exit the information level.  
Display: Normal display (depending on the program)

#### Note!

If no key is pressed for two minutes, the PLC automatically returns to the normal display.

## 1.4 Setting the system time

The current time and date need to be set immediately after start-up and after a power failure lasting more than 24 hours.

Set the **system time** in the setting level under the menu item "Datum/Uhrzeit". The **Automatic summer time** function can also be activated or deactivated in this menu item.

- ▶ **Systemzeit (System time):** Time-dependent functions of the saved program are based on the system time set in the PLC.
- ▶ **Automatische Sommerzeit (Automatic summer time):** The summer time is automatically set on the last Sunday in March at 02:00 h and the winter time on the last Sunday in October at 03:00 h.

Proceed as follows:

<div style="border: 1px solid black; padding: 5px;"> <p style="text-align: center; margin: 0;">Schlüsselzahleingabe</p> <hr/> <p style="text-align: center; margin: 10px 0 10px 40px;">0000</p> </div>	⇒	<p>Activate the editing mode.                  Display: Schlüsselzahleingabe (key number entry)  <b>0000</b> blinks</p>
<div style="border: 1px solid black; padding: 5px;"> <p style="text-align: center; margin: 0;">Einstellungsebene</p> <hr/> <p style="margin: 0;">Datum / Uhrzeit</p> <p style="margin: 0;">RS232/Slave</p> <p style="margin: 0;">RS485/Master</p> <p style="margin: 0;">RS232/Prog</p> <p style="margin: 0;">Zählerbus</p> <p style="margin: 0;">Universaleingangstyp</p> <hr/> <p style="text-align: center; margin: 0;">Zurück</p> </div>	⇩	<p>Enter the key number.</p>
<div style="border: 1px solid black; padding: 5px;"> <p style="text-align: center; margin: 0;">Einstellungsebene</p> <hr/> <p style="margin: 0;">28.11.2005 10:00</p> <p style="margin: 0;">RS232/Slave</p> <p style="margin: 0;">RS485/Master</p> <p style="margin: 0;">RS232/Prog</p> <p style="margin: 0;">Zählerbus</p> <p style="margin: 0;">Universaleingangstyp</p> <hr/> <p style="text-align: center; margin: 0;">Zurück</p> </div>	⊗	<p>Confirm the key number entered.                  Display: <u>Einstellungsebene</u> (Setting level)                  The "Datum/Uhrzeit" menu item is highlighted.</p>
<div style="border: 1px solid black; padding: 5px;"> <p style="text-align: center; margin: 0;">Einstellungsebene</p> <hr/> <p style="margin: 0;">28.11.2005 10:00</p> <p style="margin: 0;">RS232/Slave</p> <p style="margin: 0;">RS485/Master</p> <p style="margin: 0;">RS232/Prog</p> <p style="margin: 0;">Zählerbus</p> <p style="margin: 0;">Universaleingangstyp</p> <hr/> <p style="text-align: center; margin: 0;">Zurück</p> </div>	⊗	<p>Activate the menu item "Datum/Uhrzeit".                  Display: System time (DD.MM.YYYY HH:MM)</p>
<div style="border: 1px solid black; padding: 5px;"> <p style="text-align: center; margin: 0;">Einstellungsebene</p> <hr/> <p style="margin: 0;">28.11.2005 10:00</p> <p style="margin: 0;">RS232/Slave</p> <p style="margin: 0;">RS485/Master</p> <p style="margin: 0;">RS232/Prog</p> <p style="margin: 0;">Zählerbus</p> <p style="margin: 0;">Universaleingangstyp</p> <hr/> <p style="text-align: center; margin: 0;">Zurück</p> </div>	⊗	<p>Activate the editing mode for the system time.                  Display: Date (<b>DD</b>) blinks.</p>
<div style="border: 1px solid black; padding: 5px;"> <p style="text-align: center; margin: 0;">Einstellungsebene</p> <hr/> <p style="margin: 0;">28.11.2005 10:00</p> <p style="margin: 0;">RS232/Slave</p> <p style="margin: 0;">RS485/Master</p> <p style="margin: 0;">RS232/Prog</p> <p style="margin: 0;">Zählerbus</p> <p style="margin: 0;">Universaleingangstyp</p> <hr/> <p style="text-align: center; margin: 0;">Zurück</p> </div>	⇩	<p>Enter date.</p>
<div style="border: 1px solid black; padding: 5px;"> <p style="text-align: center; margin: 0;">Einstellungsebene</p> <hr/> <p style="margin: 0;">28.11.2005 10:00</p> <p style="margin: 0;">RS232/Slave</p> <p style="margin: 0;">RS485/Master</p> <p style="margin: 0;">RS232/Prog</p> <p style="margin: 0;">Zählerbus</p> <p style="margin: 0;">Universaleingangstyp</p> <hr/> <p style="text-align: center; margin: 0;">Zurück</p> </div>	⊗	<p>Confirm date entered.                  Display: Month (<b>MM</b>) blinks.</p>



Einstellungsebene
Autom. Sommerzeit ? Ein
RS232/Slave
RS485/Master
RS232/Prog
Zählerbus
Universaleingangstyp
Zurück

Einstellungsebene
28.11.2005 10:00
RS232/Slave
RS485/Master
RS232/Prog
Zählerbus
Universaleingangstyp
Zurück

Einstellungsebene
Datum / Uhrzeit
RS232/Slave
RS485/Master
RS232/Prog
Zählerbus
Universaleingangstyp
Zurück

- ⏴ Enter month.
- ⊗ Confirm month entered.  
Display: Year (YYYY) blinks.
- ⏴ Enter year.
- ⊗ Confirm year entered.  
Display: Time (HH) blinks.
- ⏴ Enter hour.
- ⊗ Confirm hour entered.  
Display: Minutes (MM) blink.
- ⏴ Enter minutes.
- ⊗ Confirm minutes entered.  
Display: "Autom. Sommerzeit ? \_\_" blinks  
If required, change the current setting (on/off) of the **Automatic summer time** function.
- ⏴ Activate function: Autom. Sommerzeit ? Ein
- ⏴ Deactivate function: Autom. Sommerzeit ? Aus
- ⊗ Exit the menu item "Datum/Uhrzeit".  
Display: Einstellungsebene (Setting level)

### Exiting the setting level

- ⏴ Select *Zurück* (back).
- ⊗ Exit the setting level.  
Display: Normal display (depending on the program)

### Note!

If no key is pressed for two minutes, the PLC automatically returns to the normal display.

## 2 Start-up

### 2.1 Programming

Programming the PLC requires a PC with ISaGRAF® software.

The ISaGRAF® software enables you to program a control system that is tailored to the specific needs of your plant (ISaGRAF® development environment 1400-7621). Programming must follow the structures and rules stipulated in IEC 61131-3. The PLC may be programmed with the languages defined in the standard: Sequential Function Chart (SFC), Instruction List (IL), Flow Chart (FC), Function Block Diagram (FBD), Ladder Diagram (LD), and Structured Text (ST).

There are 128 KB of memory available in the PLC for the ISaGRAF® program.

The program is compiled to machine code in the PC environment. This code is then transferred to the PLC over the front **RJ-45 jack** (connecting cable 1400-7308).

#### Programming languages:

Sequential Function Chart (SFC):	Used to describe operations of a sequential process with a simple graphic representation
Instruction List (IL):	Low-level textual language for logic and arithmetic operations
Flow Chart (FC):	High-level language used to visualize the data flow
Function Block Diagram (FBD):	Graphics-based language for building and combining complex functions (logical, arithmetic)
Ladder Diagram (LD):	Simple graphics-based language for logical operations (boolean)
Structured Text (ST):	High level language similar to PASCAL and C especially designed for control applications

For operation and application of the ISaGRAF® environment, refer to the documentation included in the software package. To enable simple and clear programming, ready-made functions and function blocks, e.g. for boiler systems, heat exchanger sequence control, ventilation systems, heating circuits or domestic hot water systems, are available from SAMSON.

Parameters*	WE	Setting level / Range of values
Station address	255	RS232/Prog / 1 to 247, 255
Baud rate	9600	RS232/Prog / 9600, 19200

\* -> Section 5.3 (Description of communication parameters to be adjusted)

**Note!**

In ISaGRAF®, internal variables can be assigned (hexadecimal) network addresses. The status or value of the internal variable is written to the associated holding register and can be read over Modbus. The PLC holding registers 42001 to 46999 are reserved for this purpose.

**Important!** The PLC program must be reloaded after a cold start.

## 2.2 Changing PLC settings

PLC settings can only be changed after entering the valid key number.

The valid key number can be found on page 35. To avoid unauthorized use, remove the page or make the key number unreadable.

Change PLC settings in the setting level, which contains the following menu items:

- ▶ Datum/Uhrzeit (Date/time), refer to section 1.4
- ▶ RS232/Slave, refer to section 5.1
- ▶ RS485/Master, refer to section 5.2
- ▶ RS232/Prog, refer to section 2.1
- ▶ Zählerbus (Meter bus), refer to section 5.4
- ▶ Universaleingangstyp (Type of universal input), refer to section 2.3

### Proceed as follows:

Schlüsselzahleingabe
0000



Activate the editing mode.  
Display: Schlüsselzahleingabe (key number entry)  
**0000** blinks



Enter the valid key number.

Einstellungsebene
Datum / Uhrzeit
RS232/Slave
RS485/Master
RS232/Prog
Zählerbus
Universaleingangstyp
Zurück

- ⊗ Confirm the key number.  
Display: Einstellungsebene (Setting level)  
The menu item "Datum/Uhrzeit" is highlighted.
- ↓ Select the menu item in which the settings are to be changed, e.g. "RS232/Slave".
- ⊗ Activate the selected menu item.
- ↓ Select the data point which you want to change.
- ⊗ Activate the editing mode of the data point.  
Display: Data point blinks.
- ↓ Set the data point.
- ⊗ Confirm the setting.

RS232/Slave
Modbus Slave
Modem
Baudrate
Zurück

### Returning to the setting level

- ↓ Select *Back* to return to return to the setting level.
- ⊗ Exit the menu item.  
Display: Einstellungsebene (Setting level)

Einstellungsebene
Datum / Uhrzeit
RS232/Slave
RS485/Master
RS232/Prog
Zählerbus
Universaleingangstyp
Zurück

### Exiting to the setting level

- ↓ Select *Zurück (back)* to return.
- ⊗ Exit the setting level.  
Display: Normal display (depending on the program)

---

### Note!

If no key is pressed for two minutes, the PLC automatically returns to the normal display.

---

## 2.3 Configuring universal inputs

There are 17 universal inputs, which may be used as binary inputs, analog inputs (0 to 10 V, 0/4 to 20 mA) or as sensor inputs. The hardware must be configured accordingly (sensor initialization).

Refer to page 33 for the resistance values of the PTC, Pt 100 and Pt 1000 sensors.

You can also configure each universal input separately.

The following configurations are available: Pt 100/500/1000/2000, Ni 200/1000/2000, PTC, NTC, 1–2 k $\Omega$  BE, 0/4 to 20 mA and 0 to 10 V.

### Proceed as follows:

Schlüsselzahleingabe
0000

- ⇨ Activate the editing mode.  
Display: Schlüsselzahleingabe (key number entry)  
**0000** blinks

Einstellungsebene
<b>Datum / Uhrzeit</b>
RS232/Slave
RS485/Master
RS232/Prog
Zählerbus
Universaleingangstyp
Zurück

- ⏴ Enter the valid key number.
- ⊗ Confirm the key number.  
Display: Einstellungsebene (Setting level)  
The "Datum/Uhrzeit" menu item is highlighted.

Universaleingangstyp
<b>UE01=PT100↔PT1000</b>
UE02=PT100↔PT1000
UE03=PT100↔PT1000
UE04=PT100↔PT1000
UE05=PT100↔PT1000
UE06=PT100↔PT1000
↓
Zurück

- ⏴ Select the menu item "Universaleingangstyp".
- ⊗ Activate this selected menu item.  
The first universal input UE01 is highlighted.
- ⏴ Select the universal input.
- ⊗ Activate the universal input.  
Display: **UE\_** blinks.

- Select the type of universal input.  
 The inputs are available in the following order:  
 PT100↔PT1000, PT100↔PTC, NI2000, PT2000,  
 PT500, 0 – 10V, BE, 1000 – 2000Ω, PT100,  
 PT1000, NTC, PTC, NI1000, NI200, 4 – 20mA,  
 0 – 20mA

**Note!**

On selecting the universal input types PT100↔PT1000 or PT100↔PTC, this configuration applies then to all 17 universal inputs. Any inputs that have a different type need to be configured separately afterwards.

Binary inputs with terminal 10 functioning as GND are slow (delay of approx. 3 s).

Binary inputs with terminal 9 functioning as GND are fast (ms).

**If a resistance input has been selected:**

(PT100↔PT1000, PT100↔PTC, NI2000, PT2000, PT500, PT100, PT1000, NTC, PTC, NI1000 or NI200)

Universaleingangstyp
Kalibrieren ? Nein UE02=PT100↔PT1000 UE03=PT100↔PT1000 UE04=PT100↔PT1000 UE05=PT100↔PT1000 UE06=PT100↔PT1000
Zurück

- Confirm the type of universal input.  
 Display: "Kalibrieren ? Nein" blinks.

If the temperature sensor connected at the input is not to be calibrated:

- Exit the universal input.

If the temperature sensor connected at the input is to be calibrated:

- Set to "Kalibrieren ? Ja".

- Confirm calibration.  
 Display: **Temperature measured** by the sensor blinks.

Compare the temperature measured by the sensor with the temperature measured by a reference thermometer installed directly at the point of measurement.

If both temperatures are not the same:

- Correct the sensor temperature.
- Confirm corrected temperature.

Universaleingangstyp	
UE12=PT100↔PT1000	↑
UE13=PT100↔PT1000	
UE14=PT100↔PT1000	
UE15=PT100↔PT1000	
UE16=PT100↔PT1000	
UE17=PT100↔PT1000	
<b>Zurück</b>	

**If another type of universal input is selected:**

- Confirm the universal input type.

**Returning to the setting level**

- Select *Zurück (back)* to return to the setting level.
- Exit the menu item.  
Display: Einstellungsebene (Setting level)

Einstellungsebene	
Datum / Uhrzeit	
RS232/Slave	
RS485/Master	
RS232/Prog	
Zählerbus	
Universaleingangstyp	
<b>Zurück</b>	

**Exiting to the setting level**

- Select *Zurück (back)* to return.
- Exit the setting level.  
Display: Normal display (depending on the program)

## 2.4 Resetting to default values

The values in the setting level can be reset to their default values.

### **Important!**

*Resetting to default values causes a program saved in the PLC to be deleted.*

**Proceed as follows:**

1. Cut the power supply to the PLC.
2. Restart the PLC, while pressing down the reset key ↵ with a pointed object.  
„System wird initialisiert... Kaltstartwerte eingelesen!“ appears briefly on the display before the normal display with the current firmware version (displays on page 5) appears.  
The values of the setting level are the same as the default values (see section 8.1).

### 3 Manual operation

All outputs configured in manual operating mode. Refer to the wiring plan (→ section 7).





#### Note!

If the analog and binary output menus are activated without entering the key number beforehand, the key icon  appears at the top of the display when you press the enter key to confirm the setting. This setting is locked.

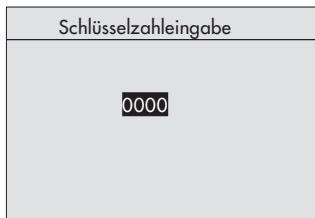



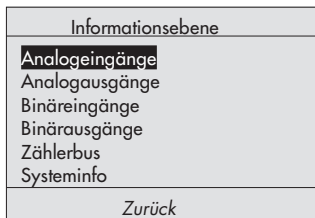

You can only change this setting after entering the key number first.

#### Proceed as follows:



-  Activate the editing mode.  
Display: Schlüsselzahleingabe (key number entry)  
**0000** blinks
-  Enter the valid key number.
-  Confirm the key number.  
Display: Einstellungsebene (Setting level)  
The "Datum/Uhrzeit" menu item is highlighted.
-  Select *Zurück* (back) to return.
-  Exit the editing mode.  
Display: Normal display (depending on program)



-   Switch to the information level.  
Display: Informationsebene (Information level)  
"Analogeingänge" menu item is highlighted.
-  Select required menu item ("Analogausgänge" (Analog outputs) or "Binärausgänge" (Binary outputs)).
-  Activate the menu item.
-  Select the required output.
-  Activate the selected output.  
Display: **AA...** or **BA...** blinks.





**Analog output setting: 0 to 10 V**

- Increase the value.
- Reduce the value.

**Setting with binary outputs: on/off**

- Binary input = on (= Ein)
- Binary input = off (= Aus)

- Exit the output.  
Display:  indicates manual intervention.

Informationsebene	
Analogeingänge	
Analogausgänge	
Binäreingänge	
Binärausgänge	
Zählerbus	
Systeminfo	
<b>Zurück</b>	

**Exiting the information level**

- Select *Zurück (back)* to return.
- Exit the information level.  
Display: Normal display (depending on program)

## 4 Operational faults

---

*Displaying errors in the error status register and sending fault alarms to a mobile phone over the SMS function or to a fax machine can be configured in ISaGRAF® to match the program. The corresponding function blocks exist for this purpose.*

---

## 5 Communication

### 5.1 Modbus slave interface

The PLC can communicate with a control system using the RS-232 Modbus slave interface. Together with the suitable process visualization software and communication software, a complete control system can be implemented.

The following interface settings are possible:

– **Operation with a dial-up modem on the RS-232 Modbus slave interface**

Basically, communication is only established automatically when events defined in the program occur. The controller works autonomously. Nevertheless, the modem can dial up to the controller at any time to read data from it or change settings, if necessary. The use of the modem connecting cable (1400-7139) is recommended.

– **Operation with a leased line modem on the RS-232 Modbus slave interface**

Communication is established over a permanent connection between two leased line modems. This setup is applied for long-distance transmissions or when different signal level converters are used. The connection between the controller and the modem can also be established over the modem connecting cable (1400-7139).

– **Operation on a four-wire bus**

To link the controller and the bus line, the signal level needs to be converted by an appropriate converter (SAMSON cable converter 1400-7308).

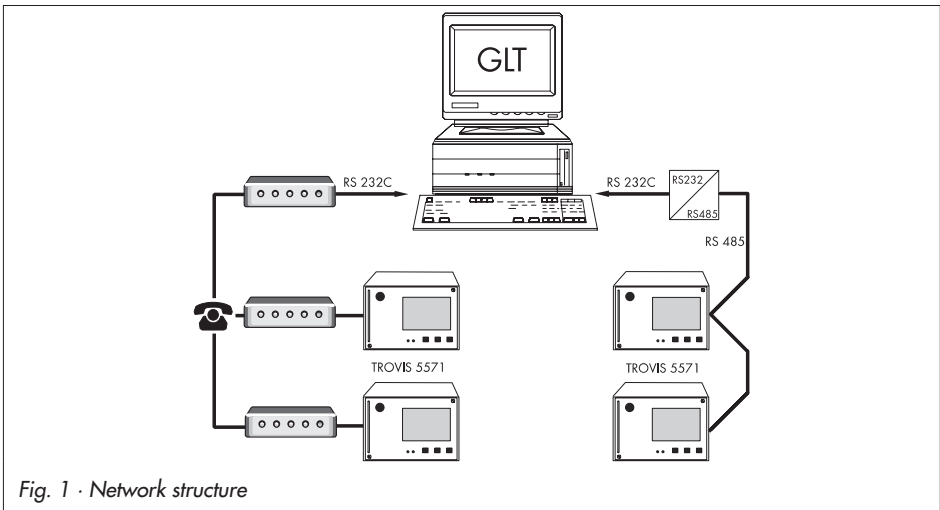

Fig. 1 · Network structure

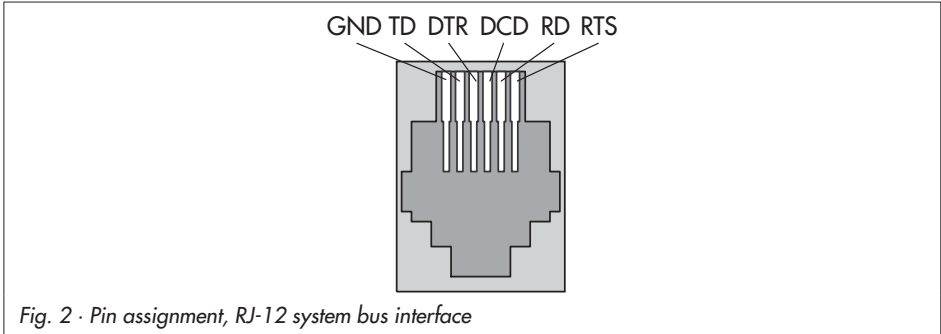

Fig. 2 · Pin assignment, RJ-12 system bus interface

### Modbus slave interface RS-232

The Modbus connection is located on the rear panel of the controller housing (RJ 12 connector). The controller can be connected either directly to the serial interface of a PC (point-to-point connection) or to a (dial-up) modem. A dial-up modem is required if the controller is to be connected to the telecommunications network. In this case, the controller operates autonomously and issues an alarm to the building control station (GLT) when faults occur. In addition, the building control station can dial up to the controller and read data from it.

Parameters*	WE	Setting level / Range of values
Station address	255	RS232/Slave > Modbus Slave / 1 to 247, 255
16-bit addressing ?	No	RS232/Slave > Modbus Slave > Station address / Yes, No
Control system monitoring	30 min	RS232/Slave > Modbus Slave / 1 to 300 min
Modem	Off	RS232/Slave Modem = On: PLC connected to telecommunications network Modem = Off: PLC directly connected to a computer
Cyclical initialization	30 min	RS232/Slave > Modem = On / 1 to 300 min
Automatic disconnection	5 min	RS232/Slave > Modem = On / 1 to 300 min
Baud rate	9600	RS232/Slave / 9600, 19200

\* -> Section 5.3 (Description of communication parameters to be adjusted)

### Modbus slave interface in combination with RS-232/RS-485 cable converters (for four-wire bus)

Operating the PLC in combination with cable converters requires a permanent bus connection (data cable). The bus line links the devices/control units in an open ring. At the end of the bus line, the data cable is connected to the control station using an RS-485/RS-232 converter (e.g. TROVIS 5484). The maximum extension (cable length) of the bus line is 1,200 m. A maximum of 32 devices can be connected to such a segment. If you wish to use more than 32 devices or need to bridge greater distances, make sure repeaters (e.g. TROVIS 5482) are installed to replicate the signal. In all, a maximum of 246 devices can be connected to a bus line.

**⚠ Caution!**

*Make sure that the relevant standards and regulations concerning lightning and overvoltage protection are observed upon installation.*

Parameters*	WE	Setting level / Range of values
Station address	255	RS232/Slave > Modbus Slave / 1 to 247, 255
16-bit addressing ?	No	RS232/Slave > Modbus Master > Station address / Yes, No
Control system monitoring	30 min	RS232/Slave > Modbus Slave / 1 to 300 min
Modem	Off	RS232/Slave / Modem = Off
Baud rate	9600	RS232/Slave / 9600, 19200

\* -> Section 5.3 (Description of communication parameters to be adjusted)

## 5.2 Modbus master interface

Modbus instruments can be connected to the PLC using the RS-485 Modbus master interface. The maximum bus line is 1,200 m. If you need to bridge greater distances, make sure repeaters (e.g. TROVIS 5482) are installed to replicate the signal.

Terminals 1 and 2 are used for connection (see Fig. 4).

**⚠ Caution!**

*Make sure that the relevant standards and regulations concerning lightning and overvoltage protection are observed upon installation.*

Parameters*	WE	Setting level / Range of values
Gateway	Off	RS485/Master / On, Off
Addressing	8 bit	RS485/Master / 8 bit, 16 bit
Baud rate	9600	RS485/Master / 9600, 19200
Frame	Off	RS485/Master / On, Off
Bias voltage	Off	RS485/Master / On, Off
Validity	600 s	RS485/Master / 0 to 600 s
Pause	0 ms	RS485/Master / 0 to 100 ms
Timeout	100 ms	RS485/Master / 100 to 10000 ms
Extension device	0	RS485/Master > Station address / 0 to 255

\* -> Section 5.3 (Description of communication parameters to be adjusted)

## 5.3 Description of communication parameters to be adjusted

### Station address (Stationsadresse)

This address is used to identify the PLC in bus or modem operation. In a system, each controller needs to be assigned a unique address.

### Addressing/16-bit addressing (Adressierung)

Selection between 16-bit addressing or 8-bit-addressing

Select RS232/Slave menu item (under *Station address*):

- ▶ 16-bit addressing? Yes – 16-bit addressing
- ▶ 16-bit addressing? No – 8-bit addressing

### Baud rate (Baudrate)

The baud rate setting refers to the transfer speed between the Modbus instruments.

### Control system monitoring (Leitsystemüberwachung)

Any intervention made by the control system on dynamic processes are restricted in time, provided that communication between the control system and the controller is not established. The controller resets the time monitoring after every valid retrieval of the station address. After the defined maximum time has elapsed, all even bits are reset to "autonomous".

### Modem (Modem)

- ▶ Modem = On (Ein):  
PLC connected to telecommunications network (RS-232 Modbus slave interface)
- ▶ Modem = Off (Aus):  
PLC directly connected to a computer (RS-232 Modbus slave interface) and on operating the PLC in combination with cable converters (RS-232/RS-485)

### Cyclical initialization (Zykl. Intialisierung)

This parameter defines the period of time for a cyclical issue of the initialization command "ATZ". The command is not issued during dial-up or when connected.

### Automatic disconnection (Autom. Abwahl)

When the controller connects to the building control station but without addressing a Modbus data point, the PLC closes the connection after the time specified for *Automatic disconnection* has elapsed.

### Gateway (Gateway)

- ▶ Gateway = On:  
Any polling by the building control station to the Modbus instruments connected to the PLC is passed directly on to the slaves.
- ▶ Gateway = Off:  
Any polling by the building control station to the Modbus instruments connected to the PLC is not passed directly on to the slaves.

### Frame (Frame)

- ▶ Frame = On:        Framing function activated
- ▶ Frame = Off:      Framing function deactivated

### Bias voltage (Vorspannung)

We recommend applying a bias voltage on the bus to keep the signal level stable. This bias voltage is usually applied to the bus by the Modbus master.

- ▶ Bias voltage = On (Ein):        Bias voltage on the bus
- ▶ Bias voltage = Off (Aus):      No bias voltage on the bus

**Validity** (Gültigkeit)

The values saved in the PLC, which have been sent by the slaves, have a time-dependent *Validity*.

If the building control station polls the saved data within the valid period of time, the PLC sends the saved data directly to the building control station. However, if the polling to the PLC is outside of this valid time period, the PLC first polls the slaves and then sends these updated data to the building control station.

**Pause** (Pause)

The time entered in *Pause* is the time that elapses before the PLC polls a slave after it has responded to the last polling by the PLC.

**Timeout** (Timeout)

If the slave does not respond to a PLC polling after the time in *Timeout* has elapsed, an alarm is generated.

**Extension device** (Erweiterungsgerät)

Extension devices are connected by specifying their station address.

## 5.4 Meter bus interface

Thanks to the meter bus interface, the PLC can communicate with up to 3 heat and water meters according to EN 1434-3.

Details on the use of the different heat and water meters can be found in the technical documentation TV-SK 6311.

### 5.4.1 Activating the meter bus

To successfully transfer data from the heat meter (WMZ) to the PLC, the heat meter must use a standardized protocol in accordance with EN 1434-3. It is impossible to make a general statement about which specific data can be accessed in each meter. For details on the different meter makes, refer to the technical documentation TV-SK 6311.

Zählerbus
<b>WMZ#1: EN1434/Cont. 250</b> WMZ#2: kein WMZ#3: kein
Zurück

All settings that are made for communication with heat or water meters are stored in Einstellungsebene (Setting level) > Zählerbus (Meter bus) > WMZ#\_.

Set the parameters in the following sequence:

- Model code
- Reading mode
- Meter bus address

- ▶ **Model code** (Typenschlüssel) [None, P15, PS2, EN1434, CAL3, APAto, SLS]  
The model code, which needs to be set for the respective heat meter, can be found in TV-SK 6311. In general, the default setting of 1434 can be used for most devices.
- ▶ **Reading mode** (Abfragemodus) [Coil, Cont, 24h]  
The meters can be read either automatically approx. every 24 hours (24h), continuously (con) or when the coils (= Modbus data points) assigned to the heat meters WMZ1 to WMZ3 are overwritten with the value 1 over the system bus interface (Coil).

**Note!**

With reading mode "24h", the displayed values are not updated by reading the status information again; the values read during the last cycle remain unchanged.

With reading mode "con", the values in the levels are not continuously updated. Reopen the specific level to get current values.

- ▶ **Meter bus address** (Adr ?) [0 to 255]  
A meter bus address must be unique and correspond with the address preset in the WMZ. If the preset meter bus address is unknown, a single heat meter connected to the controller can be assigned meter bus address 254. Address 255 deactivates communication with the respective heat meter.

Parameters	WE	Setting level / Range of values
Model code	None	Meter bus > WMZ#_ / None, P15, PS2, EN1434, CAL3, APAto, SLS
Reading mode		Meter bus > WMZ#_ / Coil, Cont, 24h
Meter bus address		Meter bus > WMZ#_ / 0 to 255

In the information level, "EN1434" is displayed when the meter bus is activated. Press the enter key to get to the display referring to the meter bus. The following information is displayed about the selected heat meter:



WMZ#1 (EN1434)	
Ident Nr.:	FFFFFFF
Durchfluß:	-.___ l/h
Volumen:	-.___ m <sup>3</sup>
Leistung:	-.___ kW
Arbeit:	-.___ Mwh
Vorlauf:	- °C
Zurück	

- ▶ Ident Nr. (ID)
- ▶ Durchfluß (Flow rate) [l/h]
- ▶ Volumen (Volume) [m<sup>3</sup>]
- ▶ Leistung (Capacity) [kW]
- ▶ Arbeit (Energy) [Mwh]
- ▶ Vorlauf (Flow temperature) [°C]
- ▶ Rücklauf (Return flow temperature) [°C]
- ▶ Zählerbusadresse (Meter bus address)
- ▶ Status (Status)

---

### Note!

A blinking icon <sup>1</sup> at the end of the header "WMZ#\_ (EN1434)" indicates an operational fault.

Check the heat/water meter connection to the meter bus interface and check the parameters set in the *Einstellungsebene (Setting level)* > *Zählerbus (Meter bus)* > *WMZ#\_*.

---

## 6 Installation

The controller consists of the housing with the electronics and the back panel with the terminals. It is suitable for panel, wall, and top hat rail mounting (Fig. 3).

### Panel mounting

1. Remove both screws (1).
2. Pull apart the controller housing and back panel.
3. Make a cut-out of 138 x 92 mm (width x height) in the control panel.
4. Insert the controller housing through the panel cut-out.
5. Insert one mounting clamp (2) each at the top and bottom or at the sides. Screw the threaded rod towards the panel with a screwdriver such that the housing is clamped against the control panel.
6. Install the electrical connections at the back of the housing as described in section 7.
7. Fit the controller housing.
8. Fasten both screws (1).

### Wall mounting

1. Remove both screws (1).
2. Pull apart the controller housing and back panel.
3. If necessary, bore holes with the specified dimensions in the appropriate places. Fasten the back panel with four screws.
4. Install the electrical connections at the back of the housing as described in section 7.
5. Fit the controller housing.
6. Fasten both screws (1).

### Top hat rail mounting

1. Fasten the spring-loaded hook (4) at the bottom of the top hat rail (3).
2. Slightly push the controller upwards and pull the upper hooks (5) over the top hat rail.

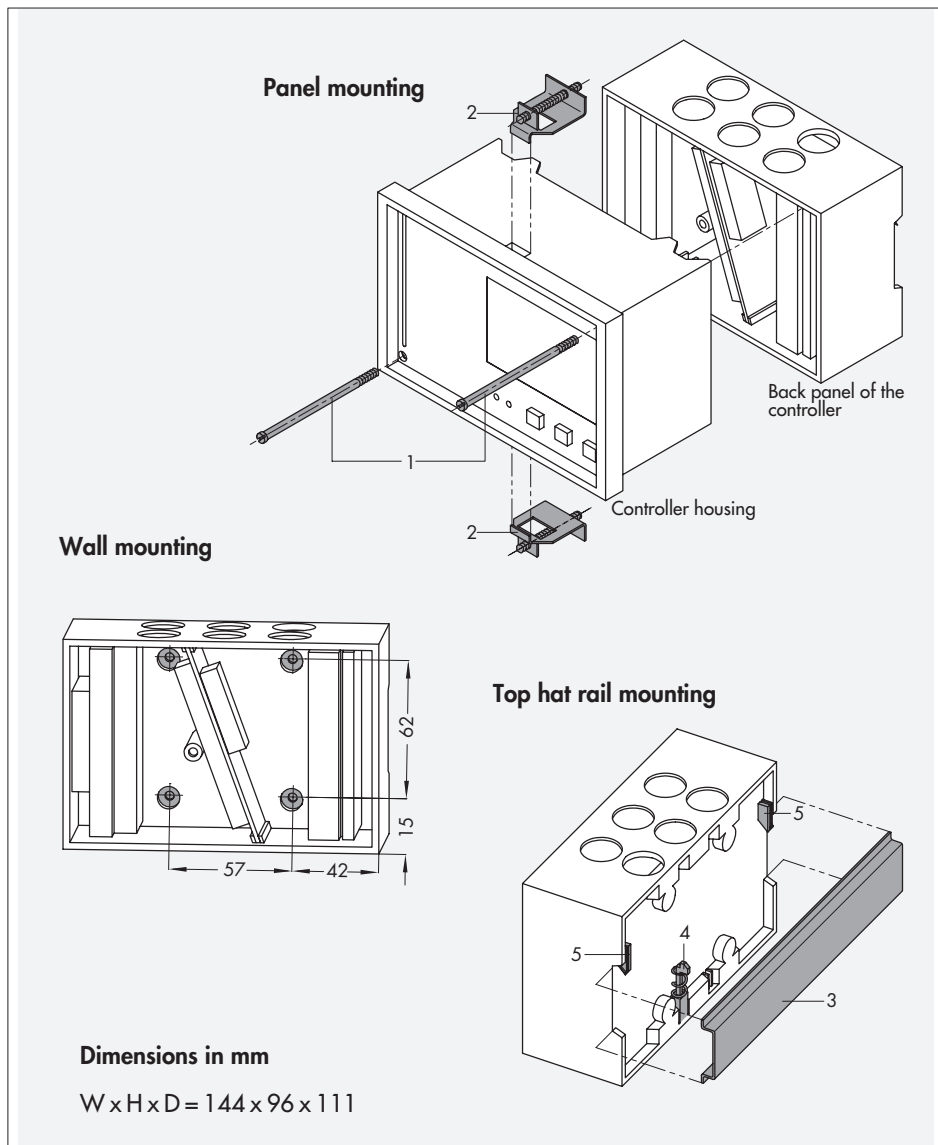

Fig. 3 · Installation

## 7 Electrical connection

---

### **Caution!**

*For electrical connection of the PLC, you are required to observe the relevant electrotechnical regulations of the country of use as well as the regulations of the local power supplier. Make sure all electrical connections are installed by trained and qualified personnel!*

---

### **Notes on installing the electrical connections**

- ▶ Install the 230 V power supply lines and the signal lines separately! To increase noise immunity, observe a minimum distance of 10 cm between the lines. Make sure the minimum distance is also observed when the lines are installed in a cabinet.
- ▶ The lines for digital signals (bus lines) and analog signals (sensor lines, analog outputs) must also be installed separately.
- ▶ In plants with a high electromagnetic noise level, we recommend to use shielded cables for the analog signal lines. Ground the shield at one side, either at the control cabinet inlet or outlet, using the largest possible cross-section. Connect the central grounding point and the PE grounding conductor with a cable  $\geq 10 \text{ mm}^2$  using the shortest route.
- ▶ Inductances in the control cabinet, e.g. contactor coils, are to be equipped with suitable interference suppressors (RC elements).
- ▶ Control cabinet elements with high field strength, e.g. transformers or frequency converters, should be shielded with separators providing a good ground connection.

### **Overvoltage protection**

- ▶ If signal lines are installed outside buildings or over large distances, make sure appropriate surge or overvoltage protection measures are taken. Such measures are indispensable for bus lines!
- ▶ The shield of signal lines installed outside buildings must have current conducting capacity and be grounded on both sides.
- ▶ Surge diverters must be installed at the control cabinet inlet.

### **Noise suppression**

The TROVIS 5571 Controller with SAMSON actuator is interference suppressed according to VDE 0875. If different actuator makes are used, or moreover, further actuators with interference sources are used in a plant, the operator/supplier of a custom-made plant must make sure that the entire plant complies with VDE 0875 regulations due to the legal obligation of ensuring interference suppression.

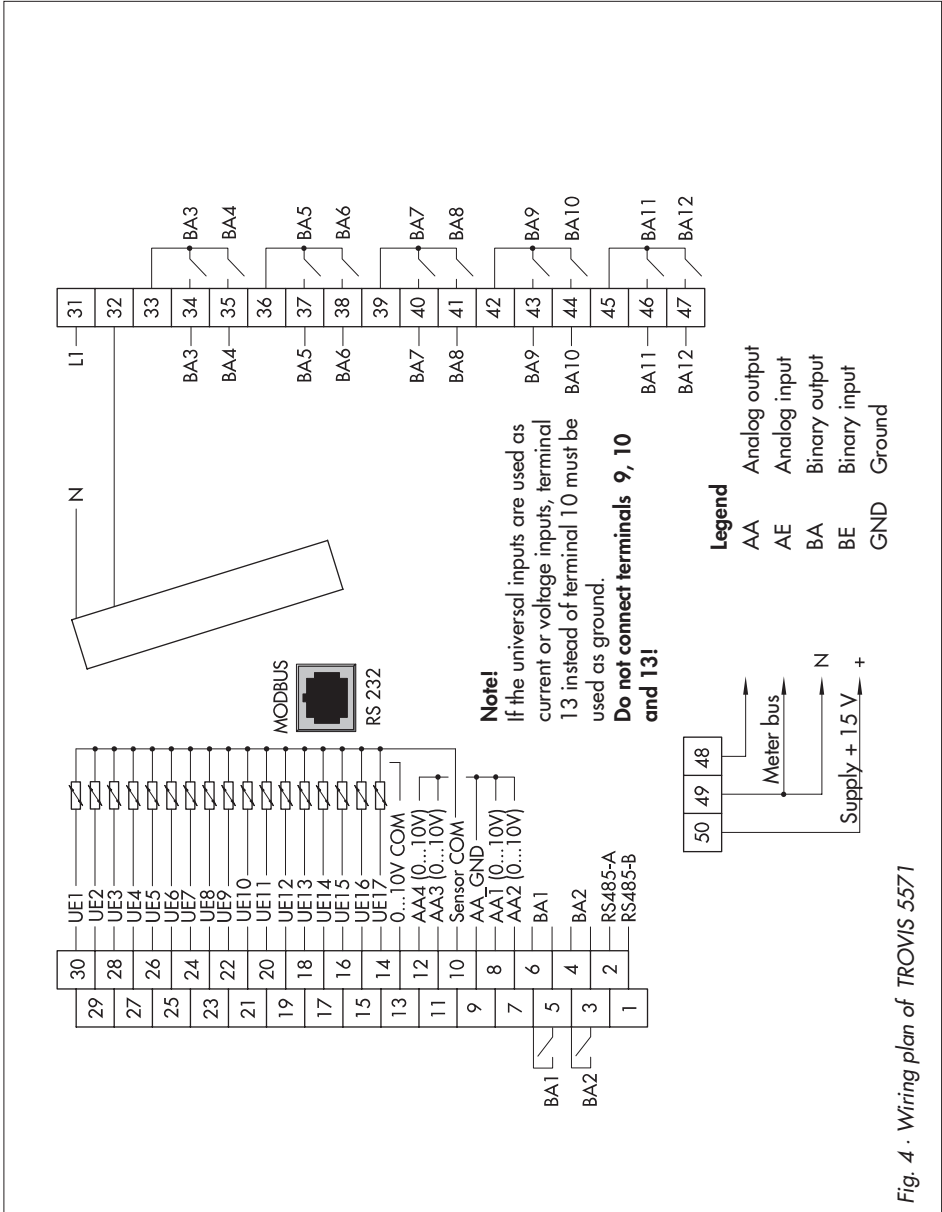

Fig. 4 · Wiring plan of TROVIS 5571

### Connecting the PLC

Open the housing to connect the cables. Make holes in the marked locations at the top, bottom or back of the housing's back panel and fit suitable grommets or screw joints.

Observe the diagram (Fig. 4) for connection. The connection diagram contains all possible inputs and outputs. The assignment of the corresponding inputs and outputs is determined by the respective program.

### Inputs

When wiring the universal inputs (BE1/AE1 to BE17/AE17), make sure to use terminal 13 as ground in case of active inputs (current and voltage inputs). If the universal inputs are used as passive inputs (sensors or binary inputs), terminal 10 must be used as ground.

Binary inputs with terminal 10 functioning as ground (GND) are slow (approx. 3 second delay). Binary inputs with terminal 9 functioning as ground (GND) are fast (ms).

### Outputs

The binary low-voltage outputs (BA1 and BA2) are used for signaling. As a result, only a minimal load can be applied to these outputs (50 V DC, max. 100 mA ohmic load). If greater loads are to be applied, it is recommended to control relays over the outputs which then switch the elevated load.

The 10 binary outputs (BA3 to BA12) can be loaded with max. 250 V AC, 2 A.

### Modbus

The controll station is connected over a serial RS-232 interface at the front of the controller.

Further Modbus instruments (slaves) are connected to the PLC over the RS-485 interface (terminals 1 and 2).

### Connecting the sensors

Cables with a minimum cross-section of  $2 \times 0.5 \text{ mm}^2$  can be connected to the terminals at the back panel of the housing.

## 8 Appendix

### 8.1 Setting level

Menu item	Functions/parameters	Setting range	WE	See section
Date/time	System time (date and time) freely configurable			
	Automatic summer time	On / Off	On	
RS232/Slave  *) Only with modem = On	Modbus slave			5.1
	Station address	1 to 247, 255	255	
	16-bit addressing	Yes / No	No	
	Control system monitoring	1 to 300 min	30 min	
	Modem Cyclical initialization *)	On / Off	Off	
	Auto. disconnection *)	1 to 300 min	30 min	
Baud rate	1 to 300 min	5 min		
RS485/Master	Gateway	9600, 19200	9600	5.2
	Addressing	On / Off	Off	
	Baud rate	8 bit, 16 bit	8 bit	
	Frame	9600, 19200	9600	
	Bias voltage	On / Off	Off	
	Validity	On / Off	Off	
	Pause	0 to 600 s	0 s	
	Timeout	0 to 100 ms	0 ms	
	Extension device	100 to 10000 ms	100 ms	
	Station address	0 to 255	0	
RS232/Prog	Station address	1 to 247, 255	255	2.1
	Baud rate	9600, 19200	9600	

Menu item	Functions/parameters	Setting range	WE	See section
Meter bus	WMZ#1 to WMZ#3 Model code  Reading mode Meter bus address	None, P15, PS2, EN1434, CAL3, APAto, SLS  Coil, Cont, 24h 0 to 255	None	
Universal input type	UE01 to UE17	PT100↔PT1000 <sup>1)2)</sup> , PT100↔PTC <sup>1)2)</sup> , NI2000 <sup>2)</sup> , PT2000 <sup>2)</sup> , PT500 <sup>2)</sup> , 0–10V, BE, 1000–2000Ω, PT100 <sup>2)</sup> , NTC <sup>2)</sup> , PTC <sup>2)</sup> , NI1000 <sup>2)</sup> , NI200 <sup>2)</sup> , 4–20mA, 0–20mA  <sup>1)</sup> Settling valid for all UE <sup>2)</sup> Calibration? Yes / No	PT100↔ PT1000	2.3



## 8.2 Sensor resistance tables

### Resistance values with PTC resistors

Type 5224 Outdoor Temperature Sensors, Types 5264 and 5265 Flow and Return Flow Temperature Sensors, Type 5264 Storage Tank Temperature Sensors

°C	-20	-10	0	10	20	25	30	40	50	60	70	80	90	100	110	120
Ω	694	757	825	896	971	1010	1050	1132	1219	1309	1402	1500	1601	1706	1815	1925

### Resistance values with Pt 1000 resistors

Type 5227-2 Outdoor Temperature Sensors, Type 5277-2 (thermowell required) and Type 5267-2 (contact sensor) Flow, Return Flow and Storage Tank Temperature Sensors. Type 5257-1, Type 5257-5 (room panel) Room Temperature Sensors.

°C	-35	-30	-25	-20	-15	-10	-5	0	5	10
Ω	862.5	882.2	901.9	921.6	941.2	960.9	980.4	1000.0	1019.5	1039.0

°C	15	20	25	30	35	40	45	50	55	60
Ω	1058.5	1077.9	1097.3	1116.7	1136.1	1155.4	1174.7	1194.0	1213.2	1232.4

°C	65	70	75	80	85	90	95	100	105	110
Ω	1251.6	1270.7	1289.8	1308.9	1328.0	1347.0	1366.0	1385.0	1403.9	1422.9

°C	115	120	125	130	135	140	145	150
Ω	1441.7	1460.6	1479.4	1498.2	1517.0	1535.8	1554.5	1573.1

### Resistance values with Pt 100 resistors

Refer to the table for Pt1 000 resistors and divide the specified values by 10.

Type 5225 Outdoor Temperature Sensors, Types 5204, 5205-46 to -48 Flow and Return Flow Temperature Sensors, Types 5205-46 to -48 Storage Tank Temperature Sensors, Type 5255 Room Temperature Sensors.

## 8.3 Technical data

Voltage supply	230 V AC, 48 to 62 Hz
Power consumption	Approx. 8 VA
Universal inputs	17 universal inputs, separately configurable as: <ul style="list-style-type: none"> <li>- Resistance input Pt 100/500/1000, Ni 200/1000/2000, PTC/NTC, 1-2 k<math>\Omega</math></li> <li>- Current input 0/4 to 20 mA (50 <math>\Omega</math> parallel resistor)</li> <li>- Voltage input 0-10 V</li> <li>- Binary input, floating</li> </ul>
Outputs	10 binary relay outputs, non-floating in pairs, 2 A / 250 V AC 2 low-voltage binary outputs, 100 mA / 50 V DC 4 analog outputs (0 to 10 V), non-floating in pairs (max. load > 4.7 k $\Omega$ )
Interfaces	
Modbus slave interface	RS-232 for modem or point-to-point communication with PC (RJ-12 jack at the back)
Optional:	Modbus interface RS-485 over cable converter 1400-7308
Modbus master interface	RS-485 for communication with other Modbus instruments (connected over terminals 1/2)
Meter bus	Connected over terminals 48/49/50
Programming interface	For installing a program created in IsaGraf <sup>®</sup> (front RJ-45 jack)
Ambient temperature	0 to 40 °C
Storage temperature	-20 to 60 °C
Degree of protection	IP 40
Class of protection	II
Degree of contamination	2
Overvoltage category	II
Humidity rating	F
Noise emission	According to EN 61000-6-3
Noise immunity	According to EN 61000-6-1
Noise suppression	According to DIN VDE 0875
Weight	Approx. 0.6 kg

**Interfaces**

Modbus slave interface	RS-232 for modem or point-to-point communication with PC (RJ-12 jack at the back) Optional: Modbus interface RS-485 over cable converter 1400-7308
Modbus master interface	RS-485 for communication with other Modbus instruments (connected over terminals 1/2)
Meter bus	Connected over terminals 48/49/50
Programming interface	For installing a program created in ISaGRAF® (RJ-45 jack at the front)

Key number

**1732**

## 8.4 Customer data

Station	
Operator	
Relevant SAMSON office	

### Settings

Functions/parameters	Setting range	Setting
<b>Date/time</b>		
System time (date and time) freely configurable		
Automatic summer time	On/Off	
<b>RS-232/slave</b>		
Station address	1 to 247, 255	
16-bit addressing	Yes/No	
Control system monitoring	1 to 300 min	
Modem	On/Off	
Cyclical initialization	1 to 300 min	
Auto. disconnection	1 to 300 min	
Baud rate	9600, 19200	
<b>RS-485/master</b>		
Gateway	On/Off	
Addressing	8 bit, 16 bit	
Baud rate	9600, 19200	
Frame	On/Off	
Bias voltage	On/Off	
Validity	0 to 600 s	
Pause	0 to 100 ms	
Timeout	100 to 10000 ms	

Extension device Station address	0 to 255	
-------------------------------------	----------	--

Meter bus		WMZ#1	WMZ#2	WMZ#3
Model code	None, P15, PS2, EN1434, CAL3, APAt0, SLS			
Reading mode	Coil, cont, 24h			
Meter bus address	0 to 255			

Universal input UE	1	2	3	4	5	6	7	8	9	10	11	12	13	14	15	16	17
PT100↔PT1000																	
PT100↔PTC																	
NI2000																	
PT2000																	
PT500																	
0–10V																	
BE																	
1000–2000Ω																	
PT100																	
NTC																	
PTC																	
NI1000																	
NI200																	
4–20mA																	
0–20mA																	

## Index

16-bit addressing . . . . .	21	<b>G</b>	Gateway . . . . .	22
8-bit addressing . . . . .	21	<b>I</b>		
<b>A</b>		Interface description . . . . .	35	
Addressing . . . . .	21	Installation		
Automatic disconnection . . . . .	22	Panel mounting . . . . .	26	
<b>B</b>		Top hat rail mounting . . . . .	26	
Baud rate . . . . .	21	Wall mounting . . . . .	26	
Bias voltage . . . . .	22	Instruction List . . . . .	10	
<b>C</b>		Interface		
Changeover key . . . . .	4	Meter bus . . . . .	23	
Configuring inputs . . . . .	13	RS-485 (Modbus master) . . . . .	20	
Connection		Internal variable . . . . .	11	
PLC . . . . .	30	ISaGRAF . . . . .	10	
Sensors . . . . .	30	<b>L</b>		
Slaves . . . . .	30	Ladder Diagram . . . . .	10	
Contrast (display) . . . . .	6	<b>M</b>		
Control system monitoring . . . . .	21	Manual operation . . . . .	16	
Controller time . . . . .	8	Meter bus . . . . .	23	
Cursor key(s) . . . . .	4	Modbus master interface . . . . .	20	
Customer data . . . . .	36	Modbus slave interface . . . . .	18	
Cyclical initialization . . . . .	22	Modem		
<b>D</b>		Dial-up modem . . . . .	18	
Display . . . . .	5	Leased line . . . . .	18	
<b>E</b>		Modem on/off . . . . .	22	
Enter key . . . . .	4	<b>N</b>		
Extension device . . . . .	23	Noise suppression . . . . .	28	
<b>F</b>		<b>O</b>		
Firmware version . . . . .	5	Operating elements . . . . .	4	
Flow Chart . . . . .	10	Operational faults . . . . .	17	
Frame . . . . .	22	Overvoltage protection . . . . .	28	
Function Block Diagram . . . . .	10			

**P**

Pause . . . . .	23
Plain text display . . . . .	5
Programming. . . . .	10

**R**

Reset key . . . . .	4
Resistance input Calibration. . . . .	14

**S**

Sensor resistance values . . . . .	33
Sequential Function Chart. . . . .	10
Station address . . . . .	21
Structured Text. . . . .	10

**T**

Technical data . . . . .	34
Timeout . . . . .	23

**V**

Validity . . . . .	23
--------------------	----

**W**

Wiring plan. . . . .	29
----------------------	----

