

## Electric Actuators

Type 5821 · Type 5822, form-fit connection

Type 5821 · Type 5822, force-locking connection

**SAMSON**



Type 5821 Electric Actuator,  
form-fit connection



Type 5822 Electric Actuator,  
force-locking connection

Fig. 1 · Electric actuators

### 1. Design and principle of operation

The electric actuators basically consist of a reversible synchronous motor of the permanent-magnet rotor type with a maintenance-free gear. The actuator components housed in the plastic enclosure are connected to the control valves using one of two methods: 1) form-fit by means of two connecting clamps and a clamp ring or 2) force-locking by means of a union nut.

Actuators with fail-safe action (Type 5822 Actuator) are equipped with a spring mechanism which, depending on the operating direction, opens or closes the connected valve.

#### Typetest

The actuators with fail-safe action OUT "actuator stem extends" have been tested acc. to DIN (DIN 32 730) in combination with various control valves. The respective register numbers are printed on the nameplate.

## 1.1 Versions - Technical data

Actuator	Form-fit Force-locking	Type	5821	-2	-3	5822	-11	-20	-21	-30	-31	-40	-41
			-1		-6	-10				-60		-70	
Fail-safe action		Without			With								
Operating direction		—			OUT	IN	OUT	IN	OUT	IN	OUT	IN	
Rated travel	mm	7.5	15	7.5	7.5	15	7.5	7.5					
Transit time for rated travel	s	90	90	40	90	90	90	40					
Transit time upon failure	s	—			8	8	8	5					
Nominal thrust	N	600	300	300	320	130	1)		1)				
Nominal closing thrust of the reset spring	N				280	170	420 <sup>1)</sup>	170	170				
Color of reset spring (form-fit version)					Yellow	Grey	Red	Grey	Grey				
Electrical connection		24, 110 or 230 V, 50 up to 60 Hz <sup>3)</sup>											
Power consumption		Motor of actuator: 4 VA											
		Electromagnet: 5 VA											
Permissible ambient temperature:		0 to + 50 °C											
Permissible storage temperature:		-20 to + 70 °C											
Permissible temperature on the connecting sleeve:		0 to +110 °C											
Degree of protection		IP 42											
Weight (approx. kg)		1.3				1.5							
Additional electrical equipment													
Limit switches		2x direction dependent											
Permissible load		a.c. voltage: 24 to 250 V, 3 A d.c. voltage: 24 V, 3 A											
Potentiometer		0 to 1000 Ω (approx. 870 Ω at rated travel), permissible load: 0.5 W <sup>2)</sup>											
Electrical positioner		Only with supply 24 V~ and version with potentiometer											
Control signal		4 to 20 mA, 0 to 20 mA, 0 to 10 V~											
Split-range operation		4 to 12 and 12 to 20 mA, 0 to 10 and 10 to 20 mA, 0 to 5 and 5 to 10 V~											

1) Depending on the springs of the connected control valve

2) Other values on request

3) 60 Hz for 5822 Actuator on request

### NOTE

The Type 5822-30 Actuator and Type 5822-31 Actuator require an external active spring force of 140 N across the entire travel in operating direction IN "actuator stem retracts". These actuators can only be combined with valves which are equipped with a corresponding valve spring, e.g., Type 3213 Control Valve or Type 3214 Control Valve.

### 1.2 Principle of operation

The actuator unit is equipped with a spring clutch which disengages the motor in the ap-

propriate final positions (torque dependently) via two limit switches.

#### Type 5821 Actuator (Figs. 2 and 3)

In these versions, the motor of the actuator is connected to the plug stem of the control valve in a form-fit manner via the gear and connecting rod. In force-locking design, a tight connection is established by means of a union nut of the actuator. The plug stem is reset by the springs built in the valve.

Manual adjustment on the handwheel (3) is only supported when the release button (2) is simultaneously pressed. This sequence disen-

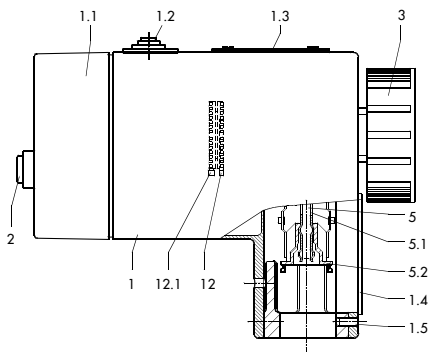

Fig. 2 · Type 5821-1, -2, -3 form-fit connection

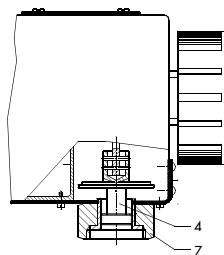

Fig. 3 · Type 5821-5, -6 force-locking connection

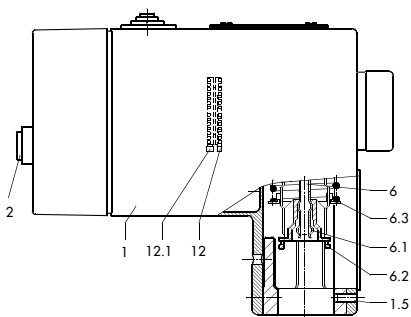

Fig. 4 · Type 5822-10, -20, -30, -40 operating direction OUT (Type 5822-11, -21, -31, -41 operating direction IN) form-fit connection

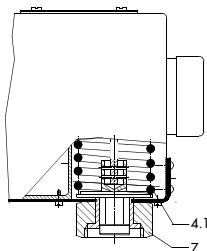

Fig. 5 · Type 5822-50, -60, -70 force-locking connection

- |                  |   |                              |
|------------------|---|------------------------------|
| 1 Body           | 3 Handwheel                                       | 6 Connecting rod (Type 5822) |
| 1.1 Body cover   | 4 Actuator stem                                   | 6.1 Connecting clamps        |
| 1.2 Cable entry  | 4.1 Spring mechanism for force-locking connection | 6.2 Clamp ring               |
| 1.3 Cover plate  | 5 Connecting rod                                  | 6.3 Spring sleeve            |
| 1.4 Nameplate    | 5.1 Connecting clamps                             | 7 Union nut                  |
| 1.5 Screw        | 5.2 Clamp ring                                    | 12 Limit switch              |
| 2 Release button |   | 12.1 Cam disk                |

gages the clutch between the gear and motor of the actuator.

#### Type 5822 Actuator (Figs. 3 and 4)

The actuators incorporating fail-safe action are essentially identical to Type 5821 Actuator presented in Fig. 2, except, however, that these actuators contain a connecting rod (6) with spring mechanism and an electromagnet. Another difference is that the handwheel (3) has been omitted.

The electromagnet which can be connected in a safety interlock circuit disengages the clutch between the gear and motor of the actuator when voltage is not applied and releases the spring mechanism. The magnet must not be used for control tasks and must not be connected again within the fail-safe closing time! The operating direction of the fail-safe action (IN or OUT) depends on the version of the spring sleeve (6.3)

### 1.3 Additional electrical equipment

The actuators can optionally be equipped with two overrangeable limit switches and/or a potentiometer.

#### Limit switches

The limit switches are actuated by two cam disks which are assigned.

#### Potentiometer

The potentiometer is coupled to an output shaft of the gear. The potentiometer has a change of resistance of approximately 870  $\Omega$  (total resistance of 1000  $\Omega$ ) in respect to the rated travels stated.

#### Electric positioners

Positioners guarantee a pre-selected correspondence between the valve stem position and the control signal. These compare the output signal of an electric controller (range 4 to 20 mA, 0 to 20 mA or 0 to 10 V-) to the position of a potentiometer which is proportional to the travel and provide a three-step control signal as output variable y.

## 2. Attaching the actuator to the control valve

Depending on the version of the control valve, the actuator can be connected to the control valve in one of two ways: 1) directly, or 2) via an adapter (connecting parts). Fig. 6. illustrates the corresponding combination.

#### NOTE

**Prior to attaching the electrical actuator to the control valve, first assemble the adapter (connecting parts) to the control valve.**

#### Force-locking version

Always connect the actuator directly to the control valve.

## 2.1 Attaching the adapter (connecting parts)

### 2.1.1 Series 240 Control Valves (up to nominal size DN 25)

Follow the assembly steps listed below:

1. Press plug stem (6) in the closing position and check whether  $x = 75$  is correct.
2. To correct, unloosen lock nut (6.2) and turn coupling nut (6.1) upwards or downwards on the plug stem (6).
3. Insert adapter (connecting part) (1) in the valve bonnet and screw tight using castellated nut (2).
4. Screw together adapter rod (3) and plug stem (6) using the two coupling clamps (4).

### 2.1.4 Series 3260 Control Valves and Type 3266 Jet Pump for temperatures above 100 °C

Follow the assembly steps listed below:

1. Insert divided bonnet (8) on the valve case and screw tight using the two terminal screws.
2. Insert rod (9) on the plug stem and screw tight using threaded pins (10).

## 2.2 Assembling the actuator to the control valve

### Force-locking version

Place actuator on the valve case and screw tight using the union nut (7).

### Form-fit version

IMPORTANT:

Pay attention to the proper assembly steps listed below; i.e., first fasten the connecting clamps (5.1 and 6.1) to the plug stem or adapter rod, then screw tight actuator to the control valve using the screws (1.5).

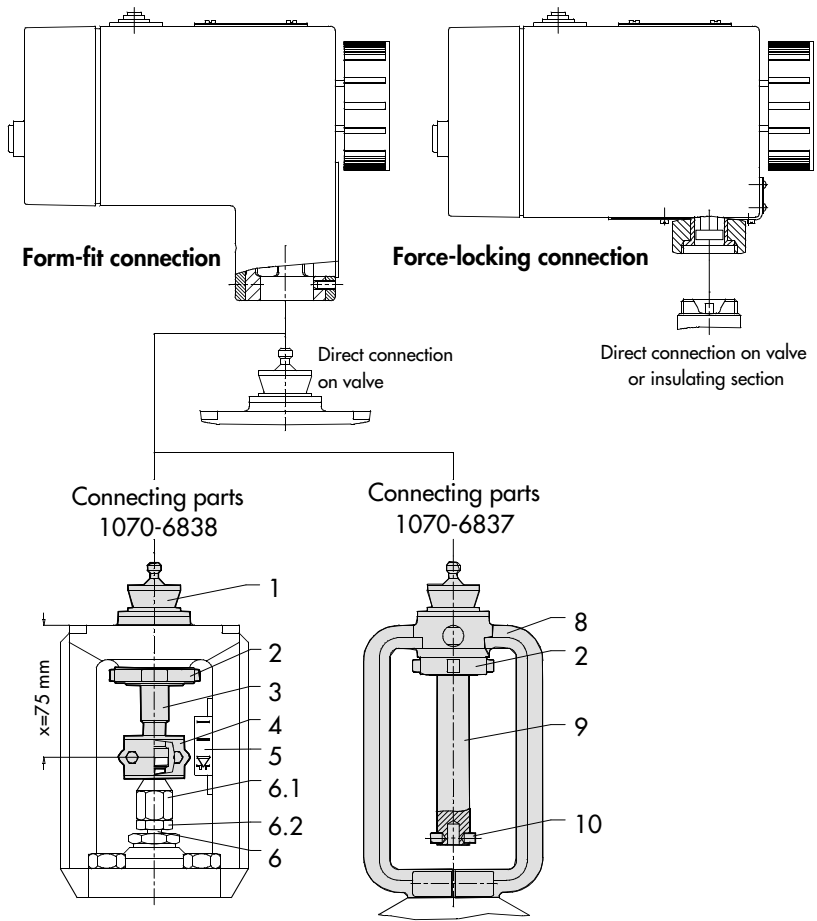

Fig. 6 · Attachment

### Type 5821 Actuator

Follow the assembly steps listed below:

1. Unscrew the nameplate (1.4) on the actuator.

#### NOTE

**When delivered, the clamp ring (5.2) is pushed upwards in the direction of the motor, the connecting clamps (5.1) are straddled and available for accommodating the plug stem and adapter rod.**

2. Place the actuator on the control valve so that the connecting clamps (5.1) slide over the headpiece of the plug stem or adapter rod.
3. Push clamp ring (5.2) downwards in the direction of the control valve until it stops so that the connecting clamps close and are locked in position. The clamp ring can be moved, for example, by inserting a screw driver at the elongated hole.

#### NOTE

**To simplify this procedure, the connecting clamps can be retracted or extended by turning the handwheel (3) when pressing the release button (2) at the same time. The locking can also be checked using this technique.**

4. After locking the actuator using the two hexagon socket head screws (1.5), screw on tight.

**To remove the actuator, perform the steps above in reverse order.**

### Type 5822 Actuator

Follow the assembly steps listed below:

1. Unscrew the nameplate (1.4) on the actuator.
2. When delivered, the clamp ring (6.2) is pushed upwards in the direction of the motor, the connecting clamps (5.1) are straddled and available for accommodating the plug stem and adapter rod.
3. Place the actuator on the control valve so that the connecting clamps (6.1) slide over the headpiece of the plug stem or adapter rod.

4. Slide the clamp ring (6.2) downwards in the direction of the control valve until it stops, causing the connecting clamps to close and lock into position. The clamp ring can be moved, for example, by inserting a screw driver at the elongated hole.
5. After locking, press the actuator against the control valve (spring mechanism must be pushed together somewhat).
6. Screw on tight using the two hexagon socket head screws (1.5).

#### NOTE

**If the spring mechanism cannot be manually pushed together any more (Type 5822-30), the actuator rod must be electrically retracted.**

6. Check the locking by applying voltage to the motor and moving the valve in the OPENED and CLOSED positions ("actuator stem retracts" and "actuator stem extends").

**To remove the actuator, perform the steps above in reverse order.**

### 3. Electrical connections

Connect the electric wires using cable entries (1.2) as depicted in the wiring diagram (Figs. 8 and 8.1).

The controller output signals are connection to terminals L1 and L2. If voltage is applied to terminal L2, the actuator motor retracts the connecting rod (5 or 6) and the plug stem of the control valve in operating direction IN "actuator stem retracts". If, in comparison, a control signal is applied to terminal L1, the connecting rod (5 or 6) is pushed downwards, i.e., operating direction OUT "actuator stem extends".

Fig. 8.1 illustrates the connection diagram relevant for versions with electric positioners. Control signals of 4 to 20 mA or 0 to 20 mA are connected to terminals 11 and 12. Control pressures 0 to 10 V are connected to terminals 12 and 13. The operating direction of the control signal can be adjusted on the positioner.

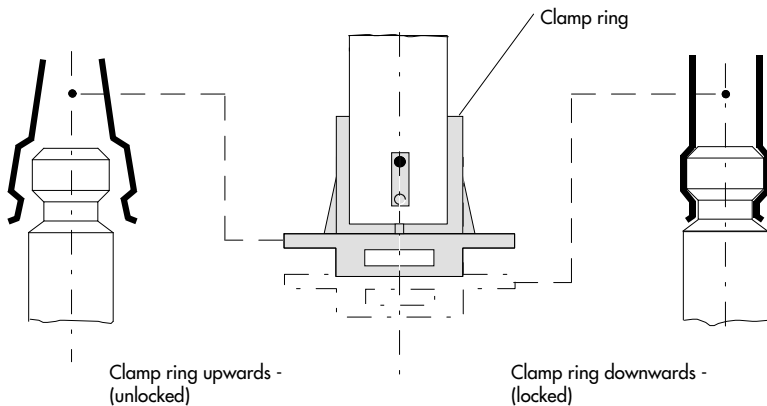
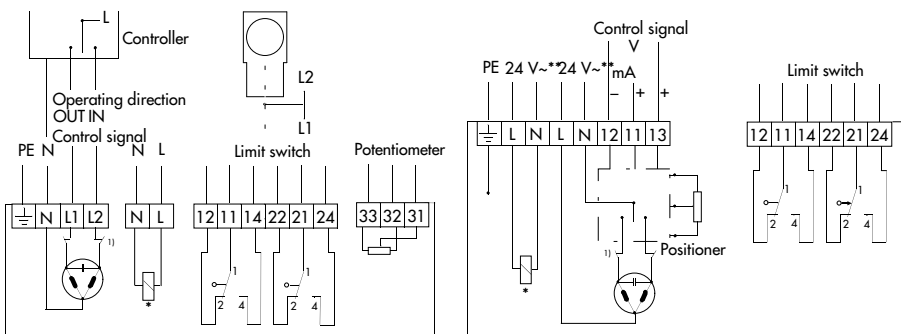

Fig. 7 · Clamp ring



\* Electromagnet for connection in a safety interlock circuit.  
 Type 5822 Actuator only  
 1) Function-related limit switch motor

\*\* Note:  
 If several actuators are wired together, e.g., in split-range operation, N must always be connected to terminal N and L to terminal L when the supply power is connected.

Fig. 8 · Wiring diagram

Fig. 8.1 · Wiring diagram, version with positioner

## 4. Operation

### 4.1 Manual operation of the actuator (Type 5821 only)

If the release button (2) is actuated, the clutch between the motor and the gear is disengaged. In this state, the control valve can be moved in the desired position by turning the handwheel.

### 4.2 Adjusting the limit switches (Fig. 9)

The limit switches can optionally be used as double-throw, normally-closed or normally-opened contacts.

The cam disks used to operate the limit switches can be adjusted after the cover plate (1.3) has been moved out of place. Each operating direction of the actuator ("actuator stem retracts" or "actuator stem extends") is assigned a separate cam disk. The desired switching point (limit value) is obtained by adjusting the appropriate cam disks.

Adjusting the direction of rotation causes either an earlier switchover point or, in the opposite direction, a later switching point.

### 4.3 Adjusting the potentiometer

To signalize the valve travel, the range of resistance from 0 to 1000  $\Omega$  is to be adjusted to the valve travel. The closing position of the valve is always important, as it is to be adjusted exactly as zero-point at 0 or 1000  $\Omega$ .

For this purpose, fasten connecting terminals to the appropriate multimeter or directly to the position indicator of the controller as indicated in the wiring diagram (Fig. 8). Move through the travel range of the actuator and adjust the potentiometer so that the resistance value or indicator exactly correspond to the final position. The potentiometer can be adjusting through the lateral opening (Fig. 10) by shifting the soldering tags using a screw driver.

### 4.4 Version with electric positioner (adjustment)

In this version, the actuator is controlled by a load-independent d.c. current or d.c. voltage signal as reference variable (input signal).

The travel of a valve (0 to 100 %) must be assigned to this input, usually a control signal in the range from 4 to 20 (0 to 20 mA) or 0 to 10 V.

In **split-range operation**, the control valves require smaller reference variables (input signals). For this purpose, the controller output signal for operating two control instruments is divided in such a way that these pass through their entire travel at half an input signal each (e.g., first control valve adjusted to 4 to 12 mA and second control valve adjusted to 12 to 20 mA). In order to avoid overlapping of the valves, a dead band of  $\pm 0.5$  mA must, if applicable, be considered (see Fig. 11).

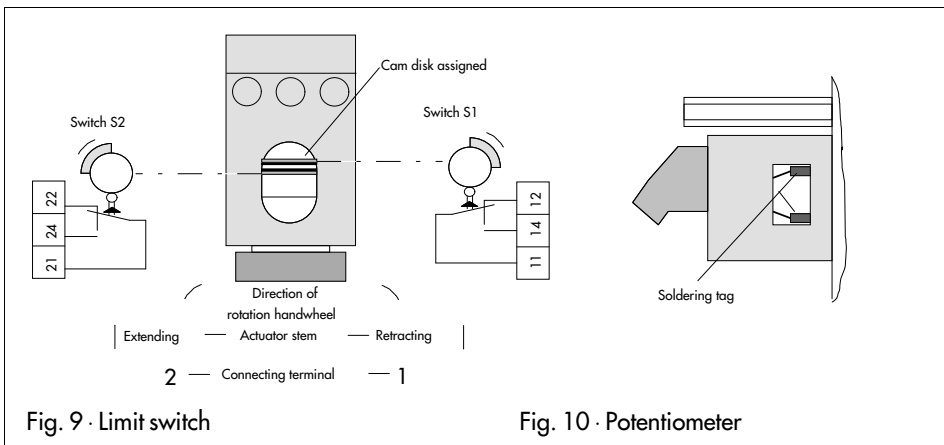



## Adjuster

The adjusters for adapting the reference variable (input signal) and travel range are located under the cover plate on the top side of the actuator.



**Zero** adjustment for initial value of the reference variable

**Jumper for operating direction**  
**Direct action >>** with increasing control signal "actuator stem retracts"

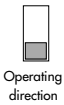

**Reverse action <>** with increasing control signal "actuator stem extends"



**Span** adjustment for the range (final value) of the control signal

## Valve adjustment

Connect the actuator's input terminal to a current or voltage source (or controller)

### Example:

A valve should move from the closed position to the opened position (travel 0 to 100 %) with an input signal of 4 to 20 mA (see Fig. 11 characteristic increasing-increasing >>).

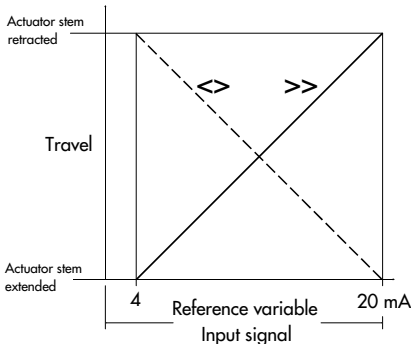

Fig. 11 · Increasing/decreasing characteristic

## Presetting:

Adjust the connector for **direct operating direction >>**, since the actuator stem must retract with increasing current input so that the valve can be opened.

Adjust the **zero adjuster** to 20 % (=4 mA) and move **span adjuster** clockwise to a small range.

If the input signal is zero, the plug stem of the control valve must rest in the lower end position, i.e. actuator stem must be extended until it stops at the plug in the valve.

## Adjustment

### Starting point (zero)

Slowly increase input signal on the source. The LED must illuminate above the zero adjuster at exactly 4 mA, indicating the run of the actuator motor. The plug stem is released from the lower end position.

A starting point which is too early or late can be corrected by slightly adjusting the value on the **zero adjuster**, decreasing input signal to zero each time and waiting until the plug stem rests in the lower end position, i.e., actuator stem must be positioned until it stops.

### Final value — span

Adjust input signal on the source to the desired final value (20 mA).

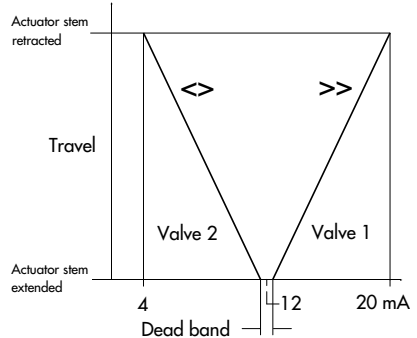

Fig. 12 · Split-range operation (two valves operating in opposite directions)

Depending on the runtime of the motor, the actuator stem and the plug stem retract in the upper end position. Note the plug stem on the travel indicator. When the desired travel position has been reached, turn span adjuster slowly counter-clockwise until the LED just begins to disilluminate. The motor then disengages, and the plug stem rests in the final position.

### **IMPORTANT**

**The starting point (zero) for the control valve always refers to the closing position (Fig. 11). With reverse operation direction (e.g., 20 to 4 mA = 0 to 100 % travel, switch position increasing-decreasing <->), the closing position assumes a value of 20 mA; the zero adjuster must then be adjusted to 100 %. Consequently, the final value (4 mA) is adjusted as described above using the span adjuster.**

5. Dimensions in mm

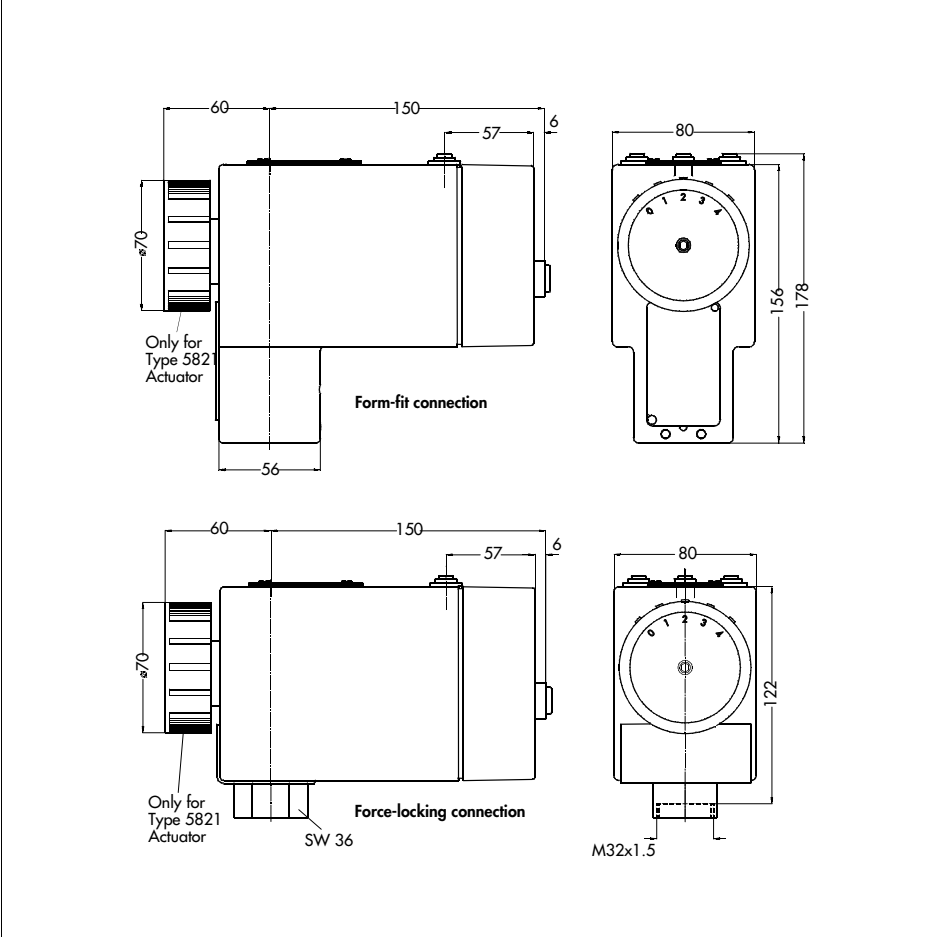



SAMSON AG · MESS- UND REGELTECHNIK  
Weismüllerstraße 3 · D-60314 Frankfurt am Main  
Postfach 10 19 01 · D-60019 Frankfurt am Main  
Telefon (0 69) 4 00 90 · Telefax (0 69) 4 00 95 07

**EB 5821/5822 E**

S/C