

## Type 3267 Valve with Jet Pump in version with screwed ends

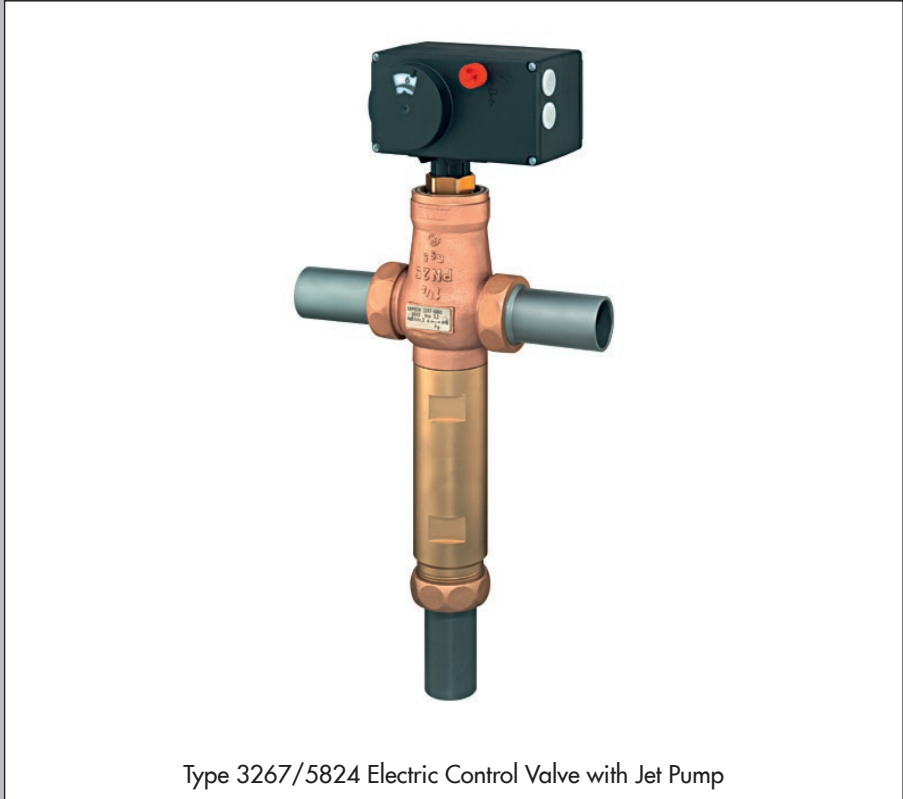

For example, as Type 3267/5857, Type 3267/5824,  
Type 3267/5825, Type 3267/5757-X, Type 3267/5724-3,  
Type 3267/5725-X Electric Control Valves with Jet Pump  
Type 3267/2780 Pneumatic Control Valve with Jet Pump



Translation of original instructions

Type 3267/5824 Electric Control Valve with Jet Pump

## Mounting and Operating Instructions

**EB 5895 EN**

Edition July 2016



## Note on these mounting and operating instructions

These mounting and operating instructions assist you in mounting and operating the device safely. The instructions are binding for handling SAMSON devices.

- For the safe and proper use of these instructions, read them carefully and keep them for later reference.
- If you have any questions about these instructions, contact SAMSON's After-sales Service Department (aftersaleservice@samson.de).



The mounting and operating instructions for the devices are included in the scope of delivery. The latest documentation is available on our website ([www.samson.de](http://www.samson.de)) > Product documentation. You can enter the document number or type number in the [Find:] field to look for a document.

## Definition of signal words

### **DANGER**

*Hazardous situations which, if not avoided, will result in death or serious injury*

### **WARNING**

*Hazardous situations which, if not avoided, could result in death or serious injury*

### **NOTICE**

*Property damage message or malfunction*

### **Note**

*Additional information*

### **Tip**

*Recommended action*

<b>1</b>	<b>Safety instructions and measures</b> .....	<b>5</b>
1.1	Notes on possible severe personal injury .....	8
1.2	Notes on possible personal injury .....	9
1.3	Notes on possible property damage .....	10
<b>2</b>	<b>Markings on the control valve</b> .....	<b>11</b>
2.1	Valve nameplate .....	11
2.2	Actuator nameplate .....	11
<b>3</b>	<b>Design and principle of operation</b> .....	<b>12</b>
3.1	Fail-safe action .....	12
3.2	Versions .....	14
3.3	Technical data .....	15
<b>4</b>	<b>Preparation</b> .....	<b>20</b>
4.1	Unpacking .....	20
4.2	Transporting and lifting .....	20
4.2.1	Transporting .....	20
4.2.2	Lifting .....	20
4.3	Storage .....	20
4.4	Preparation for installation .....	21
<b>5</b>	<b>Mounting and start-up</b> .....	<b>22</b>
5.1	Mounting the actuator onto the valve .....	22
5.2	Installing the valve into the pipeline .....	23
5.2.1	Checking the installation conditions .....	23
5.2.3	Additional fittings .....	25
5.2.4	Installing the control valve .....	25
5.2.5	Connecting the actuator .....	25
5.2.6	Configuring the actuator .....	26
5.2.7	Adjust the jet pump .....	26
5.3	Quick check .....	28
<b>6</b>	<b>Operation</b> .....	<b>30</b>
<b>7</b>	<b>Maintenance</b> .....	<b>31</b>
7.1	Preparation for return shipment .....	31
7.2	Ordering spare parts and operating supplies .....	31

<b>8</b>	<b>Malfunctions .....</b>	<b>32</b>
8.1	Troubleshooting .....	32
8.2	Emergency action .....	33
<b>9</b>	<b>Decommissioning and disassembly .....</b>	<b>34</b>
9.1	Decommissioning .....	34
9.2	Removing the valve from the pipeline .....	34
9.3	Removing the actuator from the valve .....	35
9.4	Disposal .....	35
<b>10</b>	<b>Appendix.....</b>	<b>36</b>
10.1	After-sales service .....	36
10.2	Certificates .....	36

# 1 Safety instructions and measures

## Intended use

The SAMSON Type 3267 Valve is designed for use in temperature control circuits in HVAC plants (e.g. for DHW heating). The valve is primarily combined with the following SAMSON actuators:

- As electric control valve with jet pump: Type 3267/5857, Type 3267/5824, Type 3267/5825, Type 3267/5757-3, Type 3267/5757-7, Type 3267/5724-3, Type 3267/5725-3, and Type 3267/5725-7
- As Type 3267/2780 Pneumatic Control Valve with Jet Pump

The valve with its actuator is designed to operate under exactly defined conditions (e.g. operating pressure, water as the process medium, temperature). Therefore, operators must ensure that the control valve is only used in applications that meet the specifications used for sizing the valve at the ordering stage. In case operators intend to use the control valve in other applications or conditions than specified, SAMSON must be contacted.

SAMSON does not assume any liability for damage resulting from the failure to use the valve for its intended purpose or for damage caused by external forces or any other external factors.

- ➔ Refer to the technical data and nameplate for limits and fields of application as well as possible uses.

## Reasonably foreseeable misuse

The control valve is not suitable for the following applications:

- Use outside the limits defined during sizing and in the technical data
- For Type 3267/2780 Control Valve: use outside the limits defined by the valve accessories mounted on the control valve

Furthermore, the following activities do not comply with the intended use:

- Use of non-original spare parts
- Performing maintenance and repair work not described in these instructions

### Qualifications of operating personnel

The control valve must be mounted, started up, serviced, and repaired by fully trained and qualified personnel only; the accepted industry codes and practices are to be observed. According to these mounting and operating instructions, trained personnel refers to individuals who are able to judge the work they are assigned to and recognize possible hazards due to their specialized training, their knowledge and experience as well as their knowledge of the applicable standards.

### Personal protective equipment

We recommend wearing the following protective equipment:

- Protective clothing and gloves in applications with hot or cold media
- ➔ Check with the plant operator for details on further protective equipment.

### Revisions and other modifications

Revisions, conversions or other modifications to the product are not authorized by SAMSON. They are performed at the user's own risk and may lead to safety hazards, for example. Furthermore, the product may no longer meet the requirements for its intended use.

### Safety devices

In combination with the Type 5825 Electric Actuator and with the TROVIS 5725-3 and TROVIS 5725-7 Electric Actuators with Process Controllers, the following safety feature exists: upon failure of the power supply, the valve moves to a defined fail-safe position (see section 3.1). The direction of action of the fail-safe action is defined by the actuator version (see associated actuator documentation).

In combination with the Type 2780 Pneumatic Actuator, the following safety feature exists: upon failure of the air supply, the valve moves to a certain fail-safe position (see section 3.1). The fail-safe action corresponds with the direction of action. The fail-safe action of SAMSON actuators is specified on the actuator nameplate (see actuator documentation).

### Warning against residual hazards

To avoid personal injury or property damage, plant operators and operating personnel must prevent hazards that could be caused in the control valve by the process medium, the operating pressure, the signal pressure or by moving parts by taking appropriate precautions. They must observe all hazard statements, warning and caution notes in these mounting and operating instructions, especially for installation, start-up, and maintenance.

### Responsibilities of the operator

The operator is responsible for proper operation and compliance with the safety regulations. Operators are obliged to provide these mounting and operating instructions as well as the referenced documents to the operating personnel and to instruct them in proper operation. Furthermore, operators must ensure that operating personnel or third persons are not exposed to any danger.

### Responsibilities of operating personnel

Operating personnel must read and understand these mounting and operating instructions as well as the referenced documents and observe the hazard statements, warning, and caution notes specified in them. Furthermore, the operating personnel must be familiar with the applicable health, safety and accident prevention regulations and comply with them.

### Referenced standards and regulations

The control valves comply with the requirements of the European Pressure Equipment Directive 2014/68/EC. Valves with a CE marking have a declaration of conformity, which includes information about the applied conformity assessment procedure. This declaration of conformity is included in the Appendix of these instructions (see section 10.2).

The electric actuators are designed for use in low voltage installations. For wiring, maintenance, and repair, observe the relevant safety regulations.

### Referenced documentation

The following documents apply in addition to these mounting and operating instructions:

- Mounting and operating instructions for mounted actuator, e.g. SAMSON actuators:
  - ▶ EB 5857 for Type 5857
  - ▶ EB 5824-1/-2 for Type 5824 and Type 5825
  - ▶ EB 5757-X for TROVIS 5757-X
  - ▶ EB 5724 for TROVIS 5724-3 and TROVIS 5725-3
  - ▶ EB 5725-7 for TROVIS 5725-710
  - ▶ EB 5840 for Type 2780
- For Type 3267/2780 Control Valve: mounting and operating instructions for mounted valve accessories (positioner, solenoid valve etc.)

## 1.1 Notes on possible severe personal injury

### DANGER

#### **Risk of bursting in pressure equipment.**

Control valves and pipelines are pressure equipment. Improper opening can lead to valve components bursting.

- Before starting any work on the control valve, depressurize all plant sections concerned and the valve.
- Drain the process medium from all the plant sections concerned as well as the valve.
- Wear personal protective equipment.

#### **Risk of electric shock.**

- Do not remove any covers to perform adjustment work on live parts.
- Before performing any work on the device and before opening the device, disconnect the power supply and protect it against unintentional reconnection.
- Only use power interruption devices that are protected against unintentional reconnection of the power supply.
- The electric actuators are protected against spray water (IP 54). Avoid jets of water.



## 1.2 Notes on possible personal injury

### **WARNING**

#### **Crush hazard arising from moving parts.**

The pneumatic control valve (Type 3267/2780) contains moving parts (actuator and plug stems), which can injure hands or fingers if inserted into the valve.

- While working on the control valve, disconnect and lock the pneumatic air supply as well as the control signal.

#### **Risk of personal injury when the pneumatic actuator vents.**

While the valve is operating, the pneumatic actuator (Type 2780) may vent during closed-loop control or when the valve opens or closes.

- Install the control valve in such a way that the actuator does not vent at eye level.
- Use suitable silencers and vent plugs.
- Wear eye protection when working in close proximity to the control valve.

#### **Risk of personal injury due to residual process medium in the valve.**

While working on the valve, residual process medium can escape and, depending on its properties, may lead to personal injury, e.g. burns.

- If possible, drain the process medium from all the plant sections concerned and the valve.
- Wear protective clothing and gloves.

#### **Risk of burn injuries due to hot components and pipelines.**

Depending on the process medium, valve components, and pipelines may get very hot and cause burn injuries.

- Allow components and pipelines to cool down.
- Wear protective clothing and gloves.

## 1.3 Notes on possible property damage

### ⚠ NOTICE

#### **Risk of damage to the electric control valve due to the power supply exceeding the permissible tolerances.**

The electric control valves are designed for use according to regulations for low-voltage installations.

→ Observe the permissible tolerances of the power supply. See associated actuator documentation.

#### **Risk of valve damage due to contamination (e.g. solid particles) in the pipeline.**

The plant engineering company is responsible for cleaning the pipelines in the plant.

→ Flush the pipelines before start-up.

→ Observe the maximum permissible pressure for valve and plant.

#### **Risk of valve damage due to unsuitable medium properties.**

The valve is designed for water as the process medium.

→ Do not use any other process media.

#### **Risk of leakage and valve damage due to excessively high or low tightening torques.**

Observe the specified torques on tightening control valve components. Excessively tightened torques lead to parts wearing out quicker. Parts that are too loose may cause leakage.

→ Observe the specified tightening torques.

## 2 Markings on the control valve

### 2.1 Valve nameplate

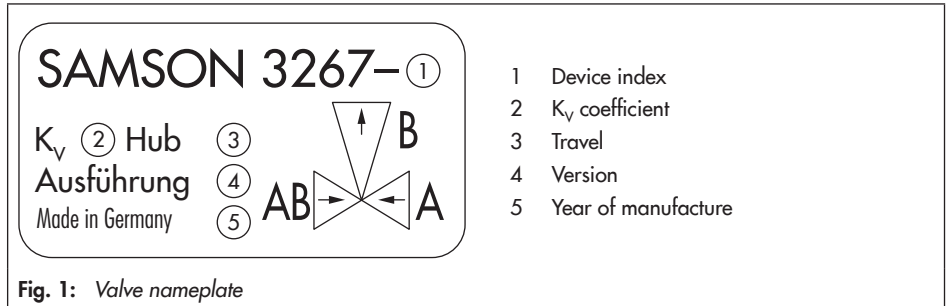

Fig. 1: Valve nameplate

The nameplate is affixed to the valve body (see Fig. 2).

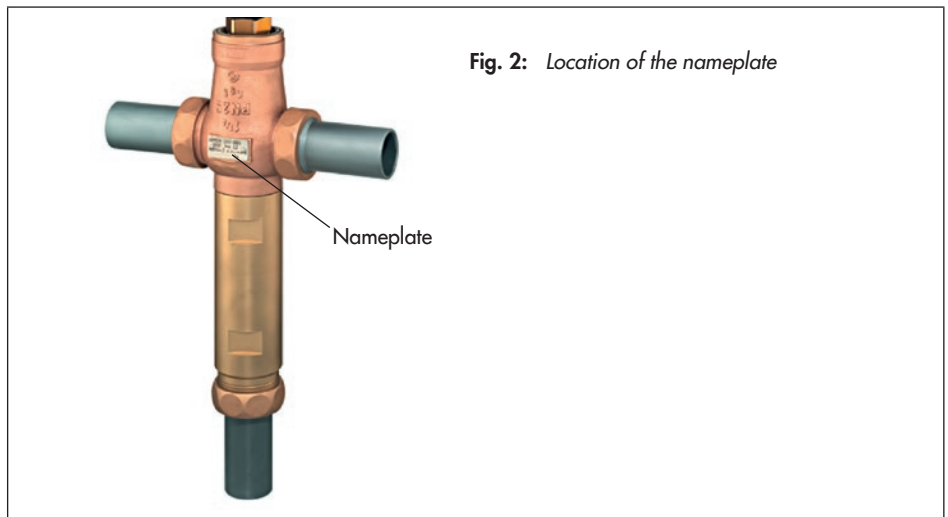

Fig. 2: Location of the nameplate

### 2.2 Actuator nameplate

See associated actuator documentation.

### 3 Design and principle of operation

Control valves with jet pumps are used in control circuits, especially in district heating supply plants. They assume both the function of a valve for temperature control and that of a circulation pump for the heating water circuit.

The control valves with jet pump consist of a valve body (1) with jet nozzle (2) and plug (3), mixing nozzle (1.1), and diffuser (1.2). The variable cross-sectional area between the valve plug and jet nozzle determines the jet stream  $Q_1$ .

The jet stream  $Q_1$  is accelerated in the jet nozzle and flows to the mixing nozzle at high speed. The exiting jet draws the partial flow  $Q_2$  with it. In the mixing nozzle, the two flows are mixed together. During the mixing process, the jet stream releases a portion of its kinetic energy to the intake flow. This exchange of energy causes an increase in pressure and, at the same time, a decrease in jet stream velocity. In the downstream diffuser, the velocity is further reduced, and the pressure increases to the output value  $p_3$ .

The turbulence in both the mixing chamber and the mixing nozzle does not only cause the exchange of energy described above, but also causes an exceptionally thorough mixing of the supplied process media. This improved mixing effect guarantees a homogeneous condition of the output flow  $Q_3$  directly downstream of the diffuser.

### 3.1 Fail-safe action

When the Type 3267 Valve is combined with one of the following actuators, the valve moves to the fail-safe position upon failure of the air supply or power supply:

- Type 5825 Electric Actuator
- TROVIS 5725-3 and TROVIS 5725-7 Electric Actuators with Process Controllers
- Type 2780 Pneumatic Actuator

The control valve has two different fail-safe positions:

- **Actuator stem extends:** upon power supply or air supply failure, the actuator stem extends.

---

#### **i** Note

*The TROVIS 5725-3 Electric Actuator with Process Controller in the version with force-locking attachment and the Type 5825 Electric Actuator with "actuator stem extends" fail-safe action are tested by the German technical surveillance association TÜV according to DIN EN 14597 in combination with the SAMSON Type 3267 Valve. The registration number is available on request.*

---

- **Actuator stem retracts:** upon power supply or air supply failure, the actuator stem retracts.

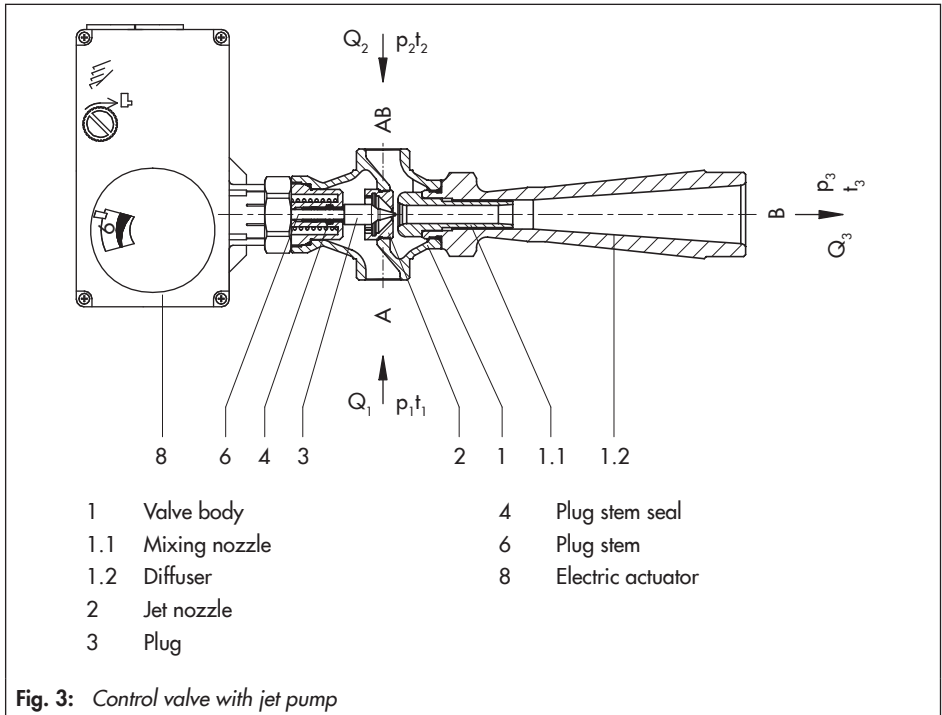

**i Note**

The fail-safe action of pneumatic actuators can be reversed (see associated actuator documentation). The fail-safe action of electric actuators (with process controllers) is already determined at the ordering stage.

## 3.2 Versions

### Intermediate insulating piece

The modular design allows an intermediate insulating piece to be fitted to the standard valve version.

**Table 1:** Available versions of control valves with jet pump

Control valve version	Nominal pressure	Nominal size DN				Actuator documentation
	PN	15	20	25	32	
<b>Electric control valves with jet pump</b>						
Type 3267/5857	25	•	•	•	–	▶ EB 5857
Type 3267/5824-X	25	•	•	•	•	▶ EB 5824-1/-2
Type 3267/5825-X <sup>1)</sup>	25	•	•	•	•	▶ EB 5824-1/-2
<b>Electric control valve with jet pump and electric actuator with process controller for domestic hot water heating</b>						
Type 3267/5757-3	25	•	•	•	–	▶ EB 5757
Type 3267/5724-3	25	•	•	•	•	▶ EB 5724
Type 3267/5725-3 <sup>1)</sup>	25	•	•	•	•	▶ EB 5724
<b>Electric control valve with jet pump and electric actuator with process controller for heating and cooling applications</b>						
Type 3267/5757-7	25	•	•	•	–	▶ EB 5757-7
Type 3267/5725-710 <sup>1)</sup>	25	•	•	•	•	▶ EB 5725-7
<b>Pneumatic control valves with jet pump</b>						
Type 3267/2780-1	25	•	•	•	•	▶ EB 5840
Type 3267/2780-2 <sup>2)</sup>	25	•	•	•	•	▶ EB 5840

<sup>1)</sup> With fail-safe action tested according to DIN EN 14597. Register number available on request.

<sup>2)</sup> Pneumatic actuator suitable for integral positioner attachment

### 3.3 Technical data

The nameplates on the valve and actuator provide information on the control valve version. See section 2.1 and the associated actuator documentation.

**Table 2:** Technical data of Type 3267 Valve in version with screwed ends

Nominal size	15	20	25	32
Connection size	G ¾	G 1	G 1¼	G 1¾
Nominal pressure	PN 25			
Rated travel	6 mm			
Permissible temperatures	-10 to +150 °C <sup>1)</sup>			
Seat-plug seal	Metal seal			
Permissible process medium	Water			
Characteristic	Linear			
Leakage class according to IEC 60534	Class IV			
Compliance				

<sup>1)</sup> **Type 3267/5857, Type 3267/5757, Type 3267/2780:** use an intermediate insulating piece for medium temperatures below 5 °C and above 110 °C.

**Type 3267/5824, Type 3267/5825, Type 3267/5724, Type 3267/5725:** use an intermediate insulating piece for medium temperatures below 5 °C and above 135 °C (networks with constant medium temperatures).

**Table 3:** Type 3267 in version with screwed ends · Nominal sizes,  $K_{VS}$  coefficients, body materials

DN	Characteristic 2: $K_{VS}$	Travel	PN/material
15	0.32 · 0.5	6 mm	PN 25/CC491K PN 25/CC499K
20	0.8 · 1.25		
25	1.0 · 1.6		
32	2.0 · 3.2		

**Table 4:** *Materials*

Nominal size	15	20	25	32
Connection size	G ¾	G 1	G 1¼	G 1¾
Body	CC491K or CC499K			
Diffuser	CC491K or CC499K			CW509L
Mixing nozzle	CW602N			
Connecting piece	-			CW617N
Jet nozzle	1.4305			
Plug and plug stem	1.4305			
Guide bushing	CW602N			
Plug stem seal	O-ring made of EPDM			

**Table 5:** *Permissible differential pressures · All pressures stated in bar (gauge)*

- The permissible differential pressures stated are nominal values. These pressures are limited by the pressure-temperature diagram and the pressure ratings. In the closed position, the leakage rate indicated in Technical data is not exceeded.
- Pneumatic control valves can only be used without a positioner in the 0.2 to 1.0 bar signal pressure range. For all other cases, a positioner is required.

Type/ TROVIS	Electric actuators (with process controllers)					Signal press.	Pneumatic actuators	
	5857 5757-3 5757-7	5824-10 5724-310	5824-13 5724-313	5825-10 5725-310 5725-710	5825-13 5725-313		2780-1	2780-2
Thrust	0.3 kN	0.7 kN	0.7 kN	0.5 kN	0.5 kN		0.4 to 1 bar	0.4 to 2 bar
$K_{vs}$	$\Delta p_H$						$\Delta p_H$	
0.32	18	25	25	25	25		25	
0.5	9	23	23	16	16		15	
0.8	9	23	23	16	16		15	
1.25	4	10.5	10.5	7	7		7	
1.0	4	10.5	10.5	7	7		7	
1.6	4	10.5	10.5	7	7		7	
2.0	-	5.5	5.5	3.5	3.5		3.5	
3.2	-	5.5	5.5	3.5	3.5		3.5	



### Noise emission

SAMSON is unable to make general statements about noise emission as it depends on the valve version, plant facilities, and process medium. On request, SAMSON can perform calculations according to IEC 60534, Part 8-3 and Part 8-4 or VDMA 24422 (edition 89).

### Dimensions and weights

Table 6 and Table 7 provide a summary of the dimensions and weights of the control valve. The lengths and heights in the dimension diagrams are shown on page 18 onwards.

**Table 6:** *Dimensions and weights for control valves with jet pump*

Nominal size A, B, AB	DN	15	20	25	32
Thread size A, B, AB		G ¾	G 1	G 1¼	G 1¾
Overall length L1	mm	65	70	75	100
Length L2	mm	100	140	180	230
Height H2	mm	45	45	45	95
Height H3	mm	175	175	175	230
Weight without actuator	kg (approx.)	0.8	1.2	2.0	6.0

**Table 7:** *Dimensions and weights for actuators*

Actuators		Type 5857 TROVIS 5757-X	Type 5824 TROVIS 5724-X	Type 5825 TROVIS 5725-X	Type 2780
Actuator area	cm <sup>2</sup>	–			120
Signal pressure connection		–			G ½
Weight	kg (approx.)	–	–	1.5	2
With handwheel	kg (approx.)	0.7	1.3	–	–

Dimensional drawings

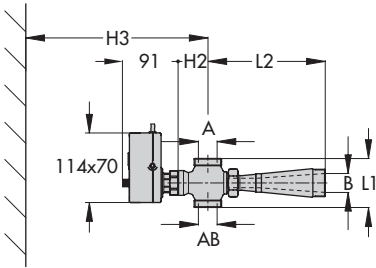

Type 3267/5857: DN 15 to 25  
Type 3267/5757-X: DN 15 to 25

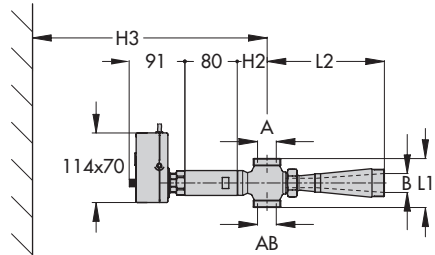

Version with intermediate insulating piece for  
temperatures below 5 °C and above 110 °C

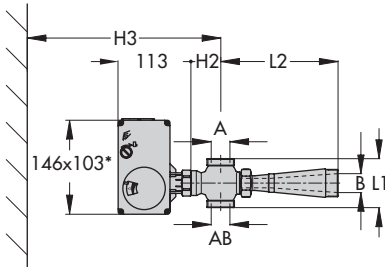

Type 3267/5824: DN 15 to 32  
Type 3267/5825: DN 15 to 32  
Type 3267/5724-3: DN 15 to 32  
Type 3267/5725-X: DN 15 to 32

\* Dimensions for Type 5824-13, Type 5825-13,  
TROVIS 5724-313, and TROVIS 5725-313:  
146 x 136

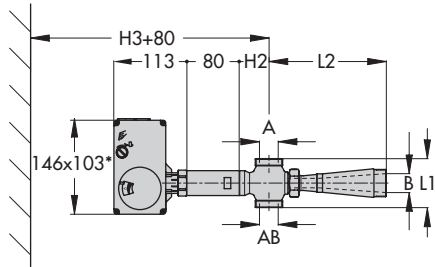

Version with intermediate insulating piece for  
temperatures below +5 °C and above +135 °C

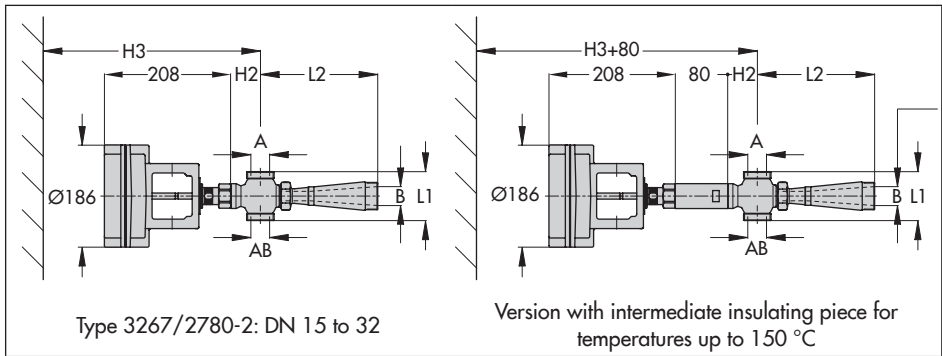
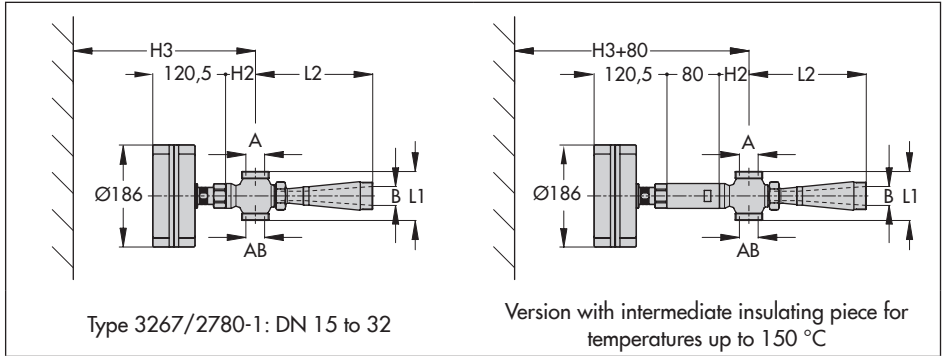

## 4 Preparation

After receiving the shipment, proceed as follows:

1. Check the scope of delivery. Compare the shipment received against the delivery note.
2. Check the shipment for transportation damage. Report any damage to SAMSON and the forwarding agent (refer to delivery note).

### 4.1 Unpacking

#### **i** Note

*Do not remove the packaging until immediately before installing the valve into the pipeline.*

Proceed as follows to lift and install the valve:

1. Remove the packaging from the valve.
2. Dispose of the packaging in accordance with the valid regulations.

### 4.2 Transporting and lifting

#### **Tip**

*SAMSON's After-sales Service department can provide more detailed transport and lifting instructions on request.*

#### 4.2.1 Transporting

- Protect the control valve against external influences (e.g. impact).
- Protect the control valve against moisture and dirt.
- Observe the permissible transportation temperature of  $-20$  to  $+65$  °C.

#### 4.2.2 Lifting

Due to the low service weight, lifting equipment is not required to lift the actuator (e.g. to mount it onto a valve).

### 4.3 Storage

#### **NOTICE**

*Risk of valve damage due to improper storage.*

- *Observe storage instructions.*
- *Avoid long storage times.*
- *Contact SAMSON in case of different storage conditions or longer storage periods.*

#### **i** Note

*We recommend regularly checking the control valve and the prevailing storage conditions during long storage times.*

#### Storage instructions

- The control valves can be stored horizontally.
- Protect the control valve against external influences (e.g. impact).

- Protect the control valve against moisture and dirt. Store it at a relative humidity of less than 75 %. In damp spaces, prevent condensation. If necessary, use a drying agent or heating.
  - Make sure that the ambient air is free of acids or other corrosive media.
  - Observe the permissible storage temperature from  $-20$  to  $+65$  °C.
  - Do not place any objects on the control valve.
  - Pack the control valve in airtight packaging.
- pressure rating of the pipeline, medium temperature etc.).
- ➔ Check any mounted pressure gauges to make sure they function.
  - ➔ When the valve and actuator are already assembled, check the bolted joints. Components may loosen during transport.

**Tip**

*SAMSON's After-sales Service department can provide more detailed storage instructions on request.*

---

## 4.4 Preparation for installation

Proceed as follows:

- ➔ Flush the pipelines.

---

**i Note**

*The plant engineering company is responsible for cleaning the pipelines in the plant.*

---

- ➔ Check the valve to make sure it is clean.
- ➔ Check the valve for damage.
- ➔ Check to make sure that the type designation, valve size, material, pressure rating and temperature range of the valve match the plant conditions (size and

### 5 Mounting and start-up

SAMSON valves are delivered ready for use. The valve and actuator are delivered separately and must be assembled on site. The procedure to mount and start up the valve are described in the following.

#### **!** NOTICE

*Risk of valve damage due to excessively high or low tightening torques.*

*Observe the specified torques on tightening control valve components. Excessively tightened torques lead to parts wearing out quicker. Parts that are too loose may cause leakage.*

### 5.1 Mounting the actuator onto the valve

Proceed as described in the actuator documentation if the valve and actuator have not been assembled by SAMSON:

- Type 5857 Electric Actuator ▶ EB 5857
- Type 5824 Electric Actuator ▶ EB 5824-1/-2
- Type 5825 Electric Actuator ▶ EB 5824-1/-2
- TROVIS 5757-3 Electric Actuator with Process Controller ▶ EB 5757
- TROVIS 5724-3 Electric Actuator with Process Controller ▶ EB 5724
- TROVIS 5725-3 Electric Actuator with Process Controller ▶ EB 5724
- TROVIS 5757-7 Electric Actuator with Process Controller ▶ EB 5757-7
- TROVIS 5725-7 Electric Actuator with Process Controller ▶ EB 5725-7
- Type 2780 Pneumatic Actuator ▶ EB 5840

#### **i** Note

*Remove the mounted actuator before mounting the other actuator (see associated actuator documentation).*

## 5.2 Installing the valve into the pipeline

### 5.2.1 Checking the installation conditions

#### Installation drawing

Fig. 4 shows the correct arrangement of the jet pump with the required additional instruments. Thermometers and pressure gauges must be installed in the generator and consumer flow pipes and in the return flow pipe. A manually operated throttle valve or balancing valve is absolutely necessary in the plant's return flow pipe. When using the jet pump in ventilation systems, a soft-start for winter conditions must be included.

The plant data used to size the jet pump must match the actual plant data to allow the jet pump to fully function. The jet pump is

sized by SAMSON based on the specifications made in the questionnaire for determining the operating conditions (TV-SK 8852).

#### Mounting position

We recommend installing the valve with jet pump with the diffuser in the horizontal position.

The mounting position of the jet pump must be lower than the consumer (e.g. radiator, air heater). This ensures that the circulation is intensified at small loads by the thermal conditions. Otherwise, difficulties may arise while the plant is in operation.

If air heaters are used, we recommend mounting the jet pumps directly to them.

→ Contact SAMSON if the mounting position is not as specified here.

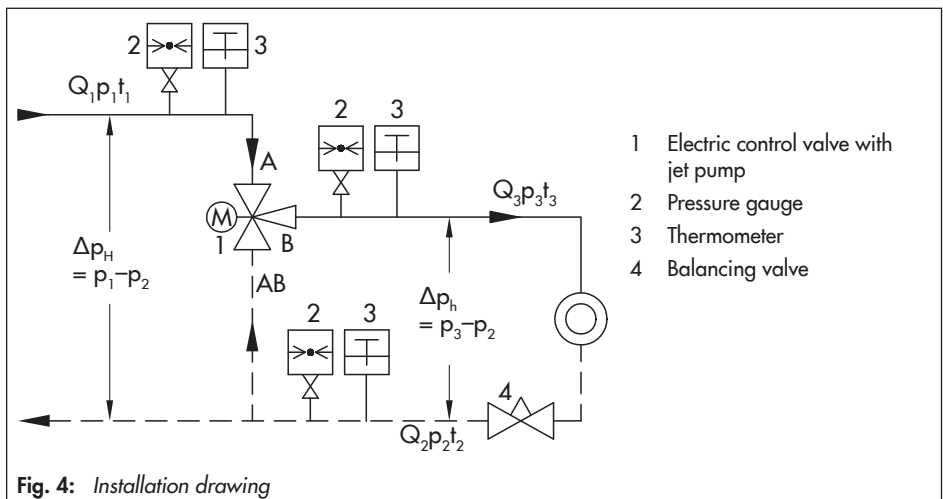

Fig. 4: Installation drawing

### Pipeline routing

To ensure the control valve functions properly, follow the installation instructions given below:

- Do not exceed the maximum permissible flow velocity.

#### **i Note**

*The plant engineering company is responsible for determining the maximum permissible flow velocity. SAMSON's After-sales Service department can support you to determine the flow velocity for your plant.*

- Install the valve free of stress and with the least amount of vibrations as possible. If necessary, attach supports to the valve.

#### **! NOTICE**

*Risk of control valve damage due to the incorrect attachment of the support. Do not attach the support to the jet pump or actuator.*

- Install the valve allowing sufficient space to remove the actuator and valve or to perform service and repair work on them.
- The flow direction of ports A, B, and AB must match those specified in the plant schematics (Fig. 4).
- Keep the mixing line AB (Fig. 4) as short as possible. Do not mount check valves or shut-off valves into the mixing line.

### Vent plug (Type 3267/2780 only)

Vent plugs are screwed into the exhaust air ports of pneumatic devices. They ensure that any exhaust air that forms can be vented to the atmosphere (to avoid excess pressure in the device). Furthermore, the vent plugs allow air intake to prevent a vacuum from forming in the device.

- Locate the vent plug on the opposite side to the workplace of operating personnel.

#### **! WARNING**

*Risk of personal injury when the actuator vents.*

- *Install the control valve in such a way that the actuator does not vent at eye level.*
- *Use suitable silencers and vent plugs.*
- *Wear eye protection when working in close proximity to the control valve.*

- On mounting valve accessories, make sure that they can be operated from the workplace of the operating personnel.

#### **i Note**

*The workplace of operating personnel is the location from which the valve, actuator and any mounted valve accessories can be accessed to operate them.*

## 5.2.2



## 5.2.3 Additional fittings

### Strainer

We recommend installing a SAMSON Type 2 NI Strainer upstream of the valve. It prevents solid particles in the process medium from damaging the valve.

- ➔ Make sure the direction of flow of the strainer and valve are the same.
- ➔ Install the strainer with the filter element facing downwards.
- ➔ Allow sufficient space to remove the filter.

### Bypass and shut-off valves

We recommend installing a shut-off valve both upstream of the strainer and downstream of the valve and setting up a bypass line. The bypass line ensures that the plant does not need to be shut down for service and repair work on the valve.

### Intermediate insulating piece

An intermediate insulating piece must be used under the following conditions:

- **Type 3267/5857, Type 3267/5757, Type 3267/2780:** for medium temperatures below 5 °C and above 110 °C
  - **Type 3267/5824, Type 3267/5825, Type 3267/5724, Type 3267/5725:** for medium temperatures below 5 °C and above 135 °C (networks with constant medium temperatures)
- ➔ Do not insulate the actuator and the coupling nut as well.
  - ➔ Only insulate the intermediate insulating piece up to 25 mm at the maximum.

## 5.2.4 Installing the control valve

### Version with screwed ends

1. Close the shut-off valve in the pipeline while the valve is being installed.
2. Lift the valve to the site of installation (see section 4.2, if necessary). Observe the flow direction through the valve. The arrow on the valve indicates the direction of flow.
3. Bolt the pipe to the screwed ends of the valve free of stress.
4. Depending on the field of application, allow the valve to cool down to reach ambient temperature before start up.
5. Slowly open the shut-off valve in the pipeline after the valve has been installed.

### ⚠ NOTICE

*Risk of valve damage due to a sudden pressure increase and resulting high flow velocities.*

*Slowly open the shut-off valve in the pipeline during start-up.*

6. Check the valve to ensure it functions properly and that there is no leakage.

## 5.2.5 Connecting the actuator

Perform the electrical or pneumatic connection of the actuator as described in the associated actuator documentation.

## 5.2.6 Configuring the actuator

The electric actuator versions with positioner as well as electric actuators with process controllers can be adapted to the control task.

Configure the actuator as described in the associated actuator documentation.

## 5.2.7 Adjust the jet pump.

### **i** Note

To adjust the jet pump, the pressure gauges and thermometers shown in Fig. 5 are necessary.

The required temperature  $t_3$  in the consumer plant results from the ratio of the flows  $Q_1$ ,  $Q_2$  and  $Q_3$  as well as the differential pressures  $\Delta p_H$  and  $\Delta p_h$  across the plant.

If the temperature  $t_3$  in the consumer plant (at full rated travel  $H_{100}$ ) is not achieved with the network pressure  $\Delta p_H$  available, the differential pressure  $\Delta p_h$  across the balancing valve (4) must be adjusted. To do this, proceed as follows:

1. Determine the flow rate ratio  $m_{100}$  from the temperatures  $t_1$ ,  $t_2$  and  $t_3$  (read off at the thermometers) using the following equation:

$$m_{100} = \frac{Q_1}{Q_3} = \frac{t_3 - t_2}{t_1 - t_2}$$

2. Determine the pressure ratio  $\epsilon_{100}$  from the pressures  $p_1$ ,  $p_2$  and  $p_3$  (read off at

the pressure gauges) using the following equation:

$$\epsilon_{100} = \frac{\Delta p_h}{\Delta p_H} = \frac{p_3 - p_2}{p_1 - p_2}$$

3. Enter the flow rate ratio  $m_{100}$  and pressure ratio  $\epsilon_{100}$  on the operating diagram (Fig. 6). The point of intersection (operating point) must be within the gray-shaded operational area. If this is not the case, the jet pump has been incorrectly sized.
4. For optimal operation, the operating point lies on the marked limit (characteristic 2). Shift the determined point of intersection horizontally (same flow rate ratio  $m_{100}$ ) until it reaches the limit and read off the corresponding pressure ratio  $\epsilon_{100}$ .
5. Using the value read from the diagram for  $\epsilon_{100}$  and the known network pressure  $\Delta p_H$ , the plant differential pressure  $\Delta p_h$  can be calculated:

$$\Delta p_h = \Delta p_H \cdot \epsilon_{100}$$

6. Adjust the balancing valve until the calculated differential pressure  $\Delta p_h$  is achieved or until the correct temperature ratio is achieved.

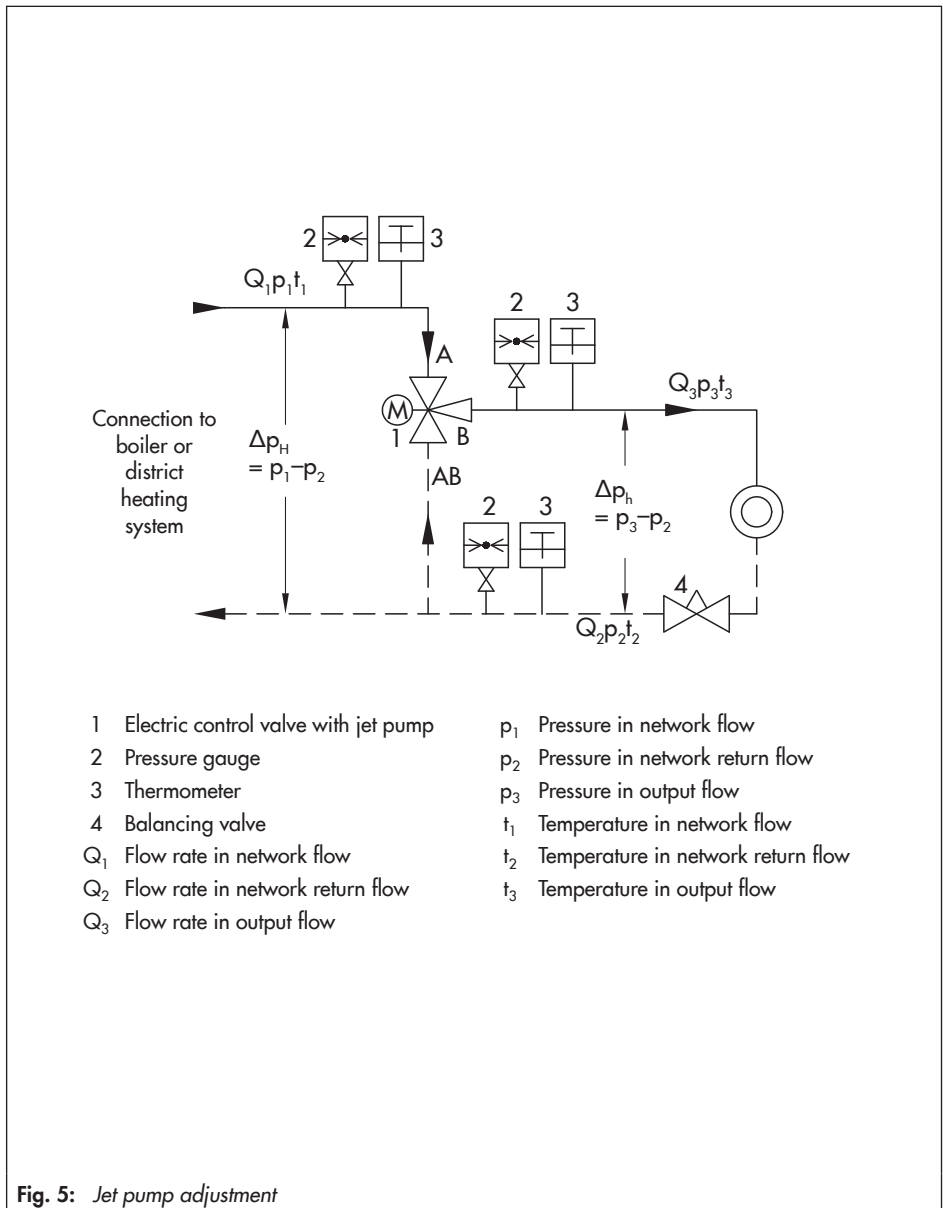
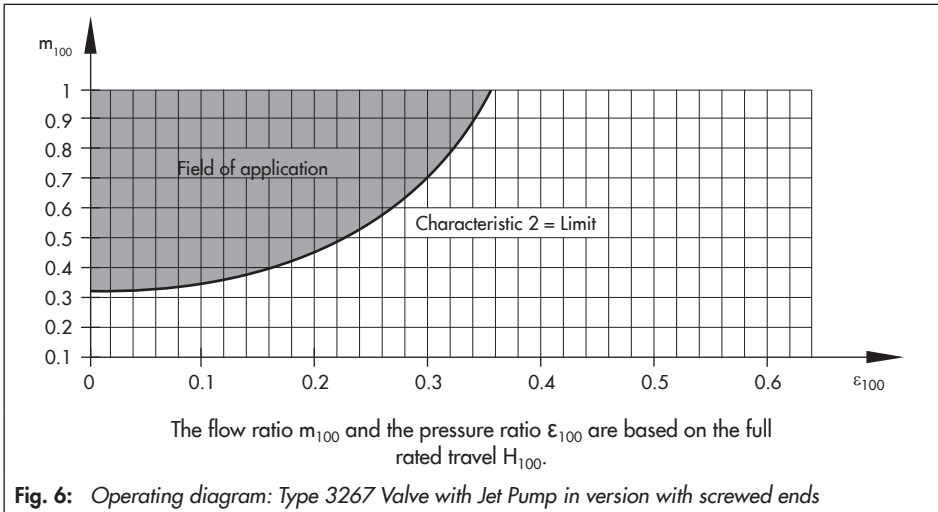

Fig. 5: Jet pump adjustment



### 5.3 Quick check

SAMSON valves are delivered ready for use. To test the valve's ability to function, the following quick checks can be performed:

#### Travel motion

The movement of the actuator stem must be linear and smooth.

- Open and close the valve, observing the movement of the travel indicator scale on the actuator.
- Apply the maximum and minimum control signals to check the end positions of the valve.

#### Fail-safe position with pneumatic actuators

- Shut off the signal pressure line.
- Check whether the valve moves to the fail-safe position.

#### Fail-safe action for electric actuators and electric actuators with process controllers with fail-safe action

- Switch off the power supply.
- Check whether the valve moves to the fail-safe position.

#### Pressure test

During the pressure test, make sure the following conditions are met:

- Retract the plug stem to open the valve.
- Observe the maximum permissible pressure for valve and plant.

---

**i Note**

*The plant engineering company is responsible for performing the pressure test. SAMSON's After-sales Service department can support you to plan and perform a pressure test for your plant.*

---

## 6 Operation

Immediately after completing mounting and start-up (see section 5), the valve is ready for use.

### **⚠ WARNING**

*Type 3267/2780: crush hazard arising from moving parts (actuator and plug stem). Do not insert hands or finger into the yoke while the valve is in operation.*

### **⚠ WARNING**

*Type 3267/2780: risk of personal injury when the actuator vents. Wear eye protection when working in close proximity to the control valve.*

### **⚠ WARNING**

*Risk of burn injuries due to hot components and pipeline. Valve components and the pipeline may become very hot. Risk of burn injuries. Wear protective clothing and gloves.*

### **ⓘ NOTICE**

*Type 3267/2780: operation disturbed by a blocked actuator or plug stem. Do not impede the movement of the actuator or plug stem by inserting objects into their path.*

### **ⓘ Note**

*The plant data used to size the jet pump must match the actual plant data to allow the jet pump to fully function. The jet pump is sized by SAMSON based on the specifications made in the questionnaire for determining the operating conditions (TV-SK 8852).*

## 7 Maintenance

---

### Note

*The control valve was checked by SAMSON before it left the factory.*

- The product warranty becomes void if maintenance or repair work not described in these instructions is performed without prior agreement by SAMSON's After-sales Service department.*
  - Only use original spare parts by SAMSON, which comply with the original specifications.*
- 

### Tip

*SAMSON's After-sales Service department can support you to draw up an inspection plan for your plant.*

---

## 7.2 Ordering spare parts and operating supplies

Contact your nearest SAMSON subsidiary or the SAMSON After-sales Service department for information on spare parts, lubricants, and tools.

### 7.1 Preparation for return shipment

Defective valves can be returned to SAMSON for repair.

Proceed as follows to return valves to SAMSON:

1. Put the control valve out of operation (see section 9).
2. Remove any residual process medium.
3. Send the control valve to your nearest SAMSON subsidiary. SAMSON subsidiaries are listed on our website at  [www.samson.de](http://www.samson.de) > Contact.

## 8 Malfunctions

Depending on the operating conditions, check the valve at certain intervals to prevent possible failure before it can occur. Operators are responsible for drawing up a test plan.



**Tip**

*SAMSON's After-sales Service department can support you to draw up an inspection plan for your plant.*

### 8.1 Troubleshooting

Malfunction	Possible reasons	Recommended action
Actuator or plug stem does not move on demand.	Actuator is blocked.	Check attachment. Unblock the actuator.
	No or incorrect power supply connected.	Check the power supply and connections.
	Signal pressure too low	Check the signal pressure. Check the signal pressure line for leakage.
Actuator or plug stem does not move through the whole range.	No or incorrect power supply connected.	Check the power supply and connections.
	Signal pressure too low	Check the signal pressure. Check the signal pressure line for leakage.
The valve leaks to the atmosphere (fugitive emissions).	Plug stem seal defective	Contact SAMSON's After-sales Service department.
Increased flow through closed valve (seat leakage)	Dirt or other foreign particles deposited between the seat and plug.	Shut off the section of the pipeline and flush the valve.
	Valve trim is worn.	Contact SAMSON's After-sales Service department.



**Note**

*Contact SAMSON's After-sales Service department for malfunctions not listed in the table.*



## 8.2 Emergency action

The valve, on which the electric actuator with fail-safe action is mounted, is moved to its fail-safe position upon power supply failure (voltage supply, signal pressure). See section 3.1.

Operators are responsible for emergency action to be taken in the plant.

In the event of a valve malfunction:

1. Close the shut-off valves upstream and downstream of the control valve to stop the process medium from flowing through the valve.
2. Check the valve for damage. If necessary, contact SAMSON's After-sales Service department.

### **Putting the valve back into operation after a malfunction**

- Slowly open the shut-off valves. Allow the process medium to flow into the valve slowly.

## 9 Decommissioning and disassembly

### **⚠ DANGER**

*Risk of bursting in pressure equipment. Control valves and pipelines are pressure equipment. Improper opening can lead to bursting of the valve.*

- Before starting any work on the control valve, depressurize all plant sections concerned and the valve.
- Drain the process medium from all the plant sections concerned as well as the valve.
- Wear personal protective equipment.

### **⚠ DANGER**

*Risk of electric shock.*

- Before performing any work on the device and before opening the device, disconnect the power supply and protect it against unintentional reconnection.
- Only use power interruption devices that are protected against unintentional reconnection of the power supply.

### **⚠ WARNING**

*Risk of personal injury due to residual process medium in the valve.*

*While working on the valve, residual process medium can escape and, depending on its properties, may lead to personal injury, e.g. burns.*

*Wear protective clothing and gloves.*

### **⚠ WARNING**

*Risk of burn injuries due to hot components and pipeline.*

*Valve components and the pipeline may become very hot. Risk of burn injuries.*

- Allow components and pipelines to cool down.
- Wear protective clothing and gloves.

## 9.1 Decommissioning

To decommission the control valve for disassembly, proceed as follows:

1. Close the shut-off valves upstream and downstream of the control valve to stop the process medium from flowing through the valve.
2. Completely drain the pipelines and valve.
3. Disconnect and lock the pneumatic air supply or power supply to depressurize or de-energize the actuator.
4. If necessary, allow the pipeline and valve components to cool down.

## 9.2 Removing the valve from the pipeline

1. Put the control valve out of operation (see section 9.1).
2. Undo the screwed ends.
3. Remove the valve from the pipeline (see section 4.2).

### 9.3 Removing the actuator from the valve

See associated actuator documentation.

### 9.4 Disposal

- Observe local, national, and international refuse regulations.
- Do not dispose of components, lubricants, and hazardous substances together with your other household waste.

## 10 Appendix

### 10.1 After-sales service

Contact SAMSON's After-sales Service department for support concerning maintenance or repair work or when malfunctions or defects arise.

#### E-mail

You can reach the After-sales Service Department at [aftersaleservice@samson.de](mailto:aftersaleservice@samson.de).

#### Addresses of SAMSON AG and its subsidiaries

The addresses of SAMSON AG, its subsidiaries, representatives, and service facilities worldwide can be found on the SAMSON website, in all SAMSON product catalogs or on the back of these Mounting and Operating Instructions.

#### Required specifications

Please submit the following details:

- Order number and position number in the order
- Type, model number, nominal size, and valve version
- Pressure and temperature of the process medium
- Flow rate in m<sup>3</sup>/h
- Bench range (e.g. 0.2 to 1 bar) or input signal of the actuator (e.g. 0 to 20 mA or 0 to 10 V)
- Is a strainer installed?
- Installation drawing

### 10.2 Certificates

The declarations of conformity are included on the next pages.



**EU-KONFORMITÄTSERKLÄRUNG  
EU DECLARATION OF CONFORMITY**

**Modul/Module D / N° CE-PED-D-SAM 001-13-DEU**

SAMSON erklärt in alleiniger Verantwortung für folgende Produkte/explains in sole responsibility for the following products:

Geräte/Devices	Bauart/Series	Typ/Type	Ausführung/Version	
Stellgerät für Heißwasser und Dampf mit Sicherheitsfunktion/Safety Accessories for Hot Water and Steam	3374 (2000 N)		mit Typ/with Type No. 2811, 2814, 2823, 3321, 3241, 3267 Zertifikat-Nr./Certificate No.: 01 202 931-B-11-0017	
Sicherheitsabsperreinrichtung für Feuerungsanlagen/ Safety Accessories for Firing Plants	240	3241	3241-4362 Zertifikat-Nr./Certificate No.: 01 202 931-B-11-0018	
	240	3241	3241-4364 Zertifikat-Nr./Certificate No.: 01 202 931-B-11-0019	
Stellgerät für Heißwasser und Dampf mit Sicherheitsfunktion/ Safety Accessories for Hot Water and Steam	240	3241	mit/with 3271 Zertifikat-Nr./Certificate No.: 01 202 931-B-10-0006	
	240, 3267	3241, 3267	mit/with 3271 und/and 3277, 240cm <sup>2</sup> Zertifikat-Nr./Certificate No.: 01 202 931-B-10-0007	
	240, 3267	3241, 3267	mit/with 3271 und/and 3277, 350cm <sup>2</sup> Zertifikat-Nr./Certificate No.: 01 202 931-B-10-0008	
	240	3241	auch druckentlastet/also pressure relieved mit/with 3271 und/and 3277 Zertifikat-Nr./Certificate No.: 01 202 931-B-10-0009	
	3274 (1800 N)			mit/with 3241, 2423, 2823, 3267 Zertifikat-Nr./Certificate No.: 01 202 931-B-10-0027
	3274 (3000 N)			mit/with 3241, 3214, 2814 Zertifikat-Nr./Certificate No.: 01 202 931-B-10-0028
Stellgerät für Wasser und Dampf mit Sicherheitsfunktion/ Safety Accessories for Water and Steam	3222, 3213, 2488, 2489, 2487, 2491, 2494, 2495, 2423, 3214	2770	mit/with 3267, 2814, 2823, 2710, 2730 Zertifikat-Nr./Certificate No.: 01 202 931-B-09-0008	
Sicherheitsabsperreinrichtung für Gasbrenner und Gasgeräte/Safety Accessories for Gas-burners and Gas-Equipment	240	3241	3241-0261 bis/to 3241-0275 Zertifikat-Nr./Certificate No.: 01 202 931-B-02-0017	
Stellgerät zur Leckgasableitung für Gasbrenner und Gasgeräte/Control Valve for draining for Gas-burners and Gas-equipm.	240	3241	3241-4321 Zertifikat-Nr./Certificate No.: 01 202 931-B-02-0018	

die Konformität mit nachfolgender Anforderung/we declare conformity with the demands of the:

Richtlinie des Europäischen Parlaments und des Rates zur Harmonisierung der Rechtsvorschriften der Mitgliedstaaten über die Bereitstellung von Druckgeräten auf dem Markt/Directive of the European Parliament and of the Council on the harmonisation of the laws of the Member States relating to the making available on the market of pressure equipment/Siehe auch Artikel 41 und 48/See also Article 41 and 48	2014/68/EU	vom/of 15.05.2014
Angewandtes Konformitätsbewertungsverfahren/ Applied Conformity Assessment Procedure für Fluide nach Art. 4 Abs. 1/for fluids acc. to Article 4, Section 1	Modul D/ Module D	durch/by Bureau Veritas 0062

Das Qualitätssicherungssystem des Herstellers wird von folgender benannten Stelle überwacht/The Manufacturer's Quality Assurance System is monitored by following Notified Body:  
Bureau Veritas S. A. nr 0062 67/71, boulevard du Château, 92200 Neuilly-sur-Seine, France

Angewandte technische Spezifikation/Technical Standards used: DIN EN12516-2; DIN EN12516-3; ASME B16.34

Hersteller/Manufacturer: **SAMSON AG, Weismüllerstraße 3, 60314 Frankfurt**

Frankfurt, 19.07.2016

*i.v. Klaus Hirsch*

*ppa Scherer*

Klaus Hirsch  
Zentralabteilungsleiter / Head of Central Department  
Entwicklung Ventile und Antriebe / R&D Valves and Actuators

Günther Scherer  
Zentralabteilungsleiter / Head of Central Department  
Qualitätsmanagement / Total Quality Management

ce\_modul\_d\_de\_en\_0001.docx



**EU-KONFORMITÄTSERKLÄRUNG  
EU DECLARATION OF CONFORMITY**

**Modul/Module H / N° CE-PED-H-SAM 001-13-DEU**

SAMSON erklärt in alleiniger Verantwortung für folgende Typen / explains in sole responsibility for the following products:

**Ventile für elektrische Stellgeräte / Globe and three-way valves equipped with electric actuators**

Typ / Type 3213, 3222 (Erz.-Nr. / Model No.. 2710); 3323, 3535 (2803); 3213, 3531 (2811); 3214 (2814); 2423E (2823); 241 (3241); 244 (3244); 267 (3267);

die Konformität mit nachfolgender Anforderung / the conformity with the following requirement.

Richtlinie des Europäischen Parlaments und des Rates zur Harmonisierung der Rechtsvorschriften der Mitgliedstaaten über die Bereitstellung von Druckgeräten auf dem Markt (siehe auch Artikel 41 und 48). 2014/68/EU vom 15.05.2014

Directive of the European Parliament and of the Council on the harmonisation of the laws of the Member States relating of the making available on the market of pressure equipment (see also Article 41 and 48). 2014/68/EU of 15.05.2014

Angewandtes Konformitätsbewertungsverfahren für Fluide nach Art. 4 Abs.1 Pkt. c.i erster Gedankenstrich. Modul siehe Tabelle durch Bureau Veritas S. A. (0062)  
Conformity assessment procedure applied for fluids according to Article 4, Section 1, Subsection c.i, first indent. For type of module, see table

DN NPS	15 ½	20 ¾	25 1	32 1¼	40 1½	50 2	65 -	80 3	100 4	125 -	150 6	200 8	250 10	300 12	400 16	
PN 25	ohne (1)			A (2)		H										-
PN 40	ohne (1)															-
Class 150	ohne (1)			A (2)		H					H					-
Class 300	ohne (1)															-

- (1) Das auf dem Stellgerät aufgebrauchte CE-Zeichen hat keine Gültigkeit im Sinne der Druckgeräterichtlinie. The CE marking affixed to the control device does not refer to the Pressure Equipment Directive.
- (2) Das auf dem Stellgerät aufgebrauchte CE-Zeichen gilt ohne Bezeichnung der Notifizierten Stelle (Kennr. 0062). The CE marking affixed to the control device is valid, but does not refer to the notified body (ID No. is invalid).

Geräte, denen laut Tabelle das Konformitätsbewertungsverfahren Modul H zugrunde liegt, beziehen sich auf die „Zulassungsbescheinigung eines Qualitätssicherungssystems“ ausgestellt durch die Notifizierte Stelle. The module H conformity assessment procedure applied to the valves according to the table is based on the "Certificate of Quality System Approval" issued by the notified body.

Der Entwurf zu Grunde gelegt sind Verfahren aus: / The design is based on the methods of: DIN EN 12516-2, DIN EN 12516-3 bzw. / respectively ASME B16.24, ASME B16.34, ASME B16.42

Das Qualitätssicherungssystem des Herstellers wird von folgender benannter Stelle überwacht. The Manufacturer's Quality Assurance System is monitored by following Notified Body

**Bureau Veritas S.A. nr 0062 67/71, boulevard du Chateau, 92200 Neuilly-sur-Seine, France  
Hersteller / Manufacturer: SAMSON AG / Weismüllerstraße 3 / 60314 Frankfurt**

Frankfurt am Main, den 19.07.2016

*Klaus Horschken*  
Klaus Horschken  
Zentralabteilungsleiter / Head of Central Department  
Entwicklung Ventile und Antriebe / Development Valves and Actuators

*Günther Scherer*  
Günther Scherer  
Zentralabteilungsleiter / Head of Central Department  
Total Quality Management / Total Quality Management

ce\_modul\_h\_und\_la\_dfe\_en\_v01.docx

SAMSON AKTIENGESELLSCHAFT  
Weismüllerstraße 3 60314 Frankfurt am Main

Telefon: 069 4009-0 · Telefax: 069 4009-1507  
E-Mail: samson@samson.de

Revision 01

## EU-KONFORMITÄTSERKLÄRUNG EU DECLARATION OF CONFORMITY

### Modul/Module H / N° CE-PED-H-SAM 001-13-DEU

SAMSON erklärt in alleiniger Verantwortung für folgende Typen / explains in sole responsibility for the following products:

#### Ventile für elektrische Antriebe / *Globe and three-way valves equipped with electric actuators*

Typ / Type 3213, 3222 (Erz.-Nr. / Model No. 2710); 3226, 3260\* (2713\*); 3323, 3535 (2803); 3213, 3531 (2811); 3214 (2814); 2423E (2823); 241 (3241); 244 (3244); 267 (3267)

die Konformität mit nachfolgender Anforderung / the conformity with the following requirement.

Richtlinie des Europäischen Parlaments und des Rates zur Harmonisierung der Rechtsvorschriften der Mitgliedstaaten über die Bereitstellung von Druckgeräten auf dem Markt (siehe auch Artikel 41 und 48). 2014/68/EU vom 15.05.2014

Directive of the European Parliament and of the Council on the harmonisation of the laws of the Member States relating of the making available on the market of pressure equipment (see also Article 41 and 48). 2014/68/EU of 15.05.2014

Angewandtes Konformitätsbewertungsverfahren für Fluide nach Art. 4 Abs.1 Pkt. c.ii und Pkt. c.i zweiter Gedankenstrich.

Modul siehe Tabelle durch certified by Bureau Veritas S. A. (0062)

Conformity assessment procedure applied for fluids according to Article 4, Section 1 Subsection c.ii and Subsection c.i second indent.

For type of module, see table

Nenndruck Nominal pressure	DN NPS	15 ½	20 ¾	25 1	32 1 ¼	40 1 ½	50 2	65	80 3	100 4	125	150 6	200 8	250 10	300 12	400 16
PN 16		ohne/without (1)					A (2)					H				
PN 25		ohne/without (1)					A (2)					H				
PN 40		ohne/without (1)					A (2)					H				
Class 150		ohne/without (1)					A (2)					H				
Class 300		ohne/without (1)					A (2)					H				

(1) Das auf dem Stellgerät aufgebrachte CE-Zeichen hat keine Gültigkeit im Sinne der Druckgeräterichtlinie  
The CE marking affixed to the control device does not refer to the Pressure Equipment Directive.

(2) Das auf dem Stellgerät aufgebrachte CE-Zeichen gilt ohne Bezeichnung der Notifizierten Stelle (Kennr. 0062)  
The CE marking affixed to the control device is valid, but does not refer to the notified body (ID No. is invalid).

\* Für Ventile vom Typ 3260 sind ab DN 150 Fluide nach Art. 4 Abs.1 Pkt. c.ii erster Gedankenstrich nicht zugelassen.  
Fluids according to Art. 4, Section 1, Subsection c.ii, first indent are not permissible for Type 3260 Valves with DN equal or bigger than 150.

Geräte, denen laut Tabelle das Konformitätsbewertungsverfahren Modul H zugrunde liegt, beziehen sich auf die „Zulassungsbescheinigung eines Qualitätssicherungssystems“ ausgestellt durch die Notifizierte Stelle.

The module H conformity assessment procedure applied to the valves according to the table is based on the "Certificate of Quality System Approval" issued by the notified body.

Dem Entwurf zu Grunde gelegt sind Verfahren aus: / The design is based on the methods of:  
DIN EN 12516-2, DIN EN 12516-3 bzw. / respectively ASME B16.1, ASME B16.24, ASME B16.34, ASME B16.42

Das Qualitätssicherungssystem des Herstellers wird von folgender benannter Stelle überwacht

The Manufacturer's Quality Assurance System is monitored by following Notified Body

Bureau Veritas S.A. nr 0062 67/71, boulevard du Chateau, 92200 Neuilly-sur-Seine, France  
Hersteller / Manufacturer: SAMSON AG / Weismüllerstraße 3 / 60314 Frankfurt

Frankfurt am Main, den 19.07.2016

  
Klaus Hörschken  
Zentralabteilungsleiter / Head of Central Department  
Entwicklung Ventile und Antriebe / Development Valves and Actuators

  
Günther Scherer  
Zentralabteilungsleiter / Head of Central Department  
Total Quality Management / Total Quality Management



SAMSON AG · MESS- UND REGELTECHNIK  
Weismüllerstraße 3 · 60314 Frankfurt am Main, Germany  
Phone: +49 69 4009-0 · Fax: +49 69 4009-1507  
samson@samson.de · www.samson.de

**EB 5895 EN**

2017-06-28 · English