



Translation of original instructions

Mounting and Operating Instructions

EB 8139 EN

Edition March 2013



Note on these mounting and operating instructions

These mounting and operating instructions assist you in mounting and operating the device safely. The instructions are binding for handling SAMSON devices.

- For the safe and proper use of these instructions, read them carefully and keep them for later reference.
- If you have any questions about these instructions, contact SAMSON's After-sales Service Department (aftersaleservice@samson.de).



The mounting and operating instructions for the devices are included in the scope of delivery. The latest documentation is available on our website (www.samson.de) > Product documentation. You can enter the document number or type number in the [Find:] field to look for a document.

Definition of signal words

DANGER

Hazardous situations which, if not avoided, will result in death or serious injury

WARNING

Hazardous situations which, if not avoided, could result in death or serious injury

NOTICE

Property damage message or malfunction

Note

Additional information

Tip

Recommended action

1	Important safety instructions	4
2	Design and principle of operation	5
2.1	Fail-safe position	6
2.2	Technical data	6
3	Installation	8
3.1	Signal pressure connection	8
4	Maintenance	9
4.1	Replacing the plug seal	10
4.2	Replacing the packing	10
4.3	Customer inquiries	13
5	Changing the spring force.....	13
6	Permissible differential pressures	14
6.1	Version FA/NC with fail-safe position: fail-close	14
6.2	Version FE/NO with fail-safe position: fail-open.....	14

1 Important safety instructions



For your own safety, follow these instructions concerning the mounting, start up and operation of the control valve:

- The control valve must be mounted, started up, or serviced by fully trained and qualified personnel only; the accepted industry codes and practices are to be observed. Make sure employees or third persons are not exposed to any danger.
- To ensure appropriate use, only use the control valve in applications where the operating pressure and temperatures do not exceed the specifications used for sizing the valve at the ordering stage. The manufacturer does not assume any responsibility for damage caused by external forces or any other external factors.
- Any hazards that could be caused in the valve by the process medium, the operating pressure and the signal pressure are to be prevented by taking appropriate precautions.
- **Important!** For installation and maintenance, make sure the relevant section of the pipeline is depressurized and, depending on the process medium, drained as well. Depending on the field of application, allow the valve to cool down or heat up to reach ambient temperature before starting any work on it.
- When working on the valve, make sure that the pneumatic air supply as well as the control signal are disconnected to prevent any hazards due to moving parts.

To avoid damage to any equipment, the following also applies:

- Proper shipping and storage are assumed.

i Note

The control valves comply with the requirements of the European Pressure Equipment Directive 2014/68/EU. Valves with a CE marking have a declaration of conformity, which includes information about the applied conformity assessment procedure. The declaration of conformity can be viewed and downloaded at ► www.samson.de.

2 Design and principle of operation

The pneumatic control valve consists of an angle seat valve with a soft-seated plug and a pneumatic piston actuator. Depending on the version, the actuator can be equipped with a mechanical manual override or an electric limit switch.

The control valve is designed for on/off service in process engineering and plants with

industrial requirements. The control valve is suitable for liquids, vapors and gases at temperatures from -10 to $180\text{ }^{\circ}\text{C}$ and a nominal pressure of PN 40.

The medium flows through the valve in the direction indicated by the arrow. The signal pressure applied to the piston actuator determines the position of the plug and thus the cross-sectional area of flow between the seat and plug.

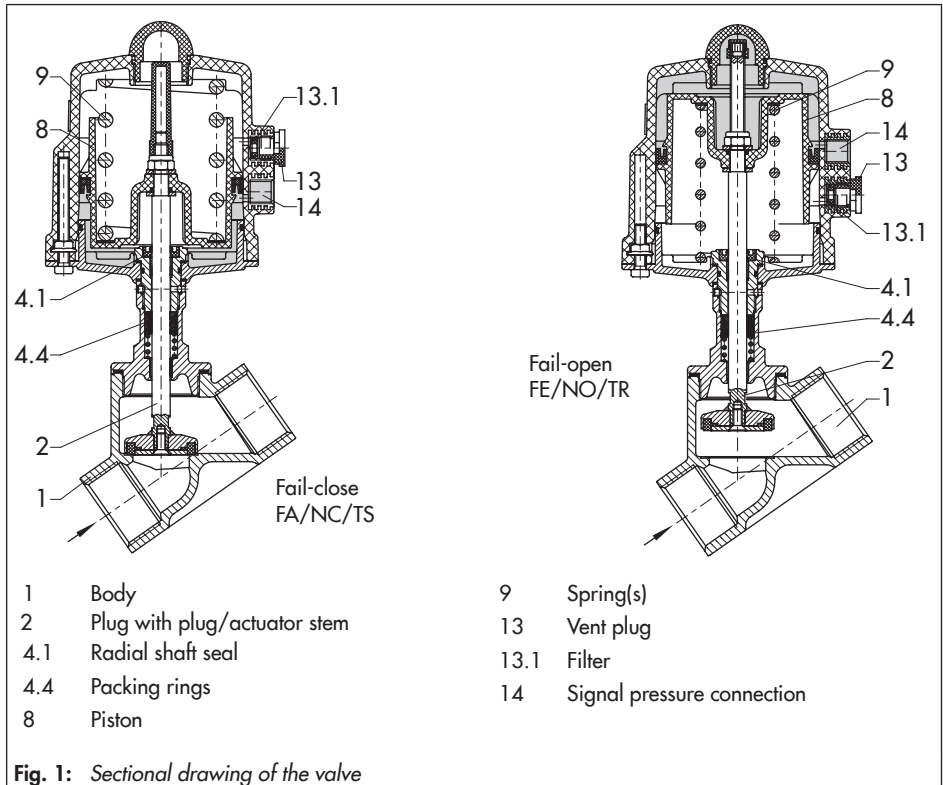

Fig. 1: Sectional drawing of the valve

The actuator stem (2) is sealed by a self-adjusting PTFE V-ring packing (4.4) at the valve and by a radial shaft seal (4.1) at the actuator.

2.1 Fail-safe position

The fail-safe position of the valve upon supply air (signal pressure) failure is determined by how the piston and actuator spring are arranged in the pneumatic actuator.

Fail-close (FA)

The actuator spring closes the valve upon air supply failure. The valve opens when the signal pressure increases.

Fail-open (FE)

The actuator spring opens the valve upon air supply failure. The valve closes when the signal pressure increases.

2.2 Technical data

Dimensions and weights are listed on page 7.

The technical data are listed in the corresponding Data Sheet ► T 8139.

Dimensions and weights

Valve size	DN (NPS)	15 (1/2)	20 (3/4)	25 (1)	32 (1 1/4)	40 (1 1/2)	50 (2)
Face-to-face dimension L	mm	65	75	90	110	120	150
End-to-end length L1	mm	170	175	197	205	210	226
Height including actuator H	mm	193	194	211	212	224	226
Body connection	G	G 1/2	G 3/4	G	G 1 1/4	G 1 1/2	G 2
Thread length t	mm	15	16	19	22	22	26
Valve weight	kg	0.28	0.33	0.64	0.8	1.3	1.9

Version with welding ends							
Valve size	DN (NPS)	15 (1/2)	20 (3/4)	25 (1)	32 (1 1/4)	40 (1 1/2)	50 (2)
Face-to-face dimension L	mm	100	120	150	160	180	190
End-to-end length L1	mm	187	197	227	218	230	241
Height including actuator H	mm	197	199	214	223	230	229
Ød1 connection	mm	18.1	23.7	29.7	38.4	44.3	55.1
Wall thickness s	mm	1.6		2			2.6
Valve weight	kg	0.28	0.33	0.64	0.8	1.3	1.9

Pneumatic piston actuator				
Version	Effective area/Ø	30 cm ² /Ø 63	60 cm ² /Ø 90 (one spring)	60 cm ² /Ø 90 (two springs)
Housing ØD	mm	100	127	
Control pressure connection		G 1/4		
Weight	kg	1.35	2.2	2.75

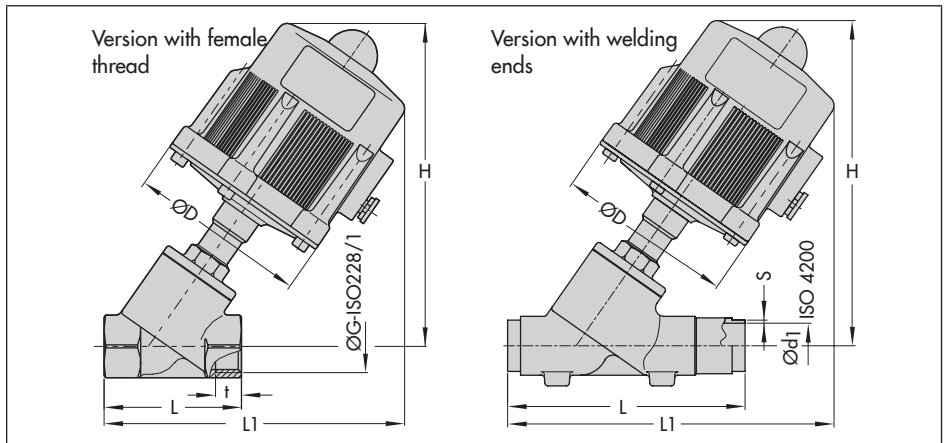

3 Installation

The control valve may be installed in any position. We recommend installing it in a horizontal pipeline with the actuator pointing upwards.

- ➔ The flow of direction must correspond with the direction indicated by the arrow on the valve body.
- ➔ Install the valve free of stress and with the least amount of vibrations as possible. If necessary, support the pipelines near the connections.
- ➔ Since sealing parts, weld spatter, and other impurities carried along by the medium may impair the tight shut-off of the seat and plug, flush out the pipeline thoroughly before installing the valve in the pipeline.

3.1 Signal pressure connection

Signal pressure connection and venting are designed as boreholes with a G ¼ female thread.

The venting hole is fitted with a replaceable filter (13.1) with order no. 0550-0213. This filter can be removed by first unscrewing the vent plug (13).

The signal pressure connection also allows an adapter plate to be attached that complies with VDI/VDE 3845 for mounting a solenoid valve.

The actuator can be turned as required to connect the signal pressure line.

Customary fittings for metal or copper tubing or plastic hoses can be used.

Blow through all air pipes and hoses thoroughly before connecting them.

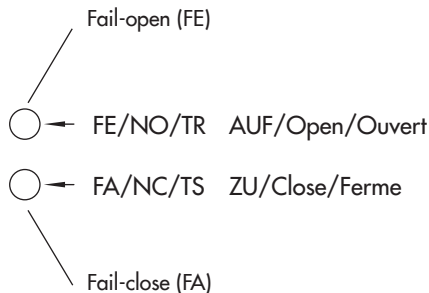

Fig. 2: Signal pressure connection

4 Maintenance

The control valve is subject to normal wear, especially at the seat, plug, and packing. Depending on the operating conditions, check the valve at regular intervals to prevent possible failure before it can occur.

If the valve does not close tightly, tight shut-off may be impaired by dirt stuck between the seat and plug or by to a damaged soft seal.

If the valve leaks, this may be due to a defective body gasket (3.1), or if the medium

leaks out of the borehole (3.2) at the side, there may possibly be a leak in the packing (4.4).

We recommend removing the parts, cleaning them, and, if necessary, replacing them with new ones.

⚠ WARNING

Before performing any work on the control valve, make sure the relevant plant section has been depressurized and drained. Wait until the medium cools down if hot media are used.

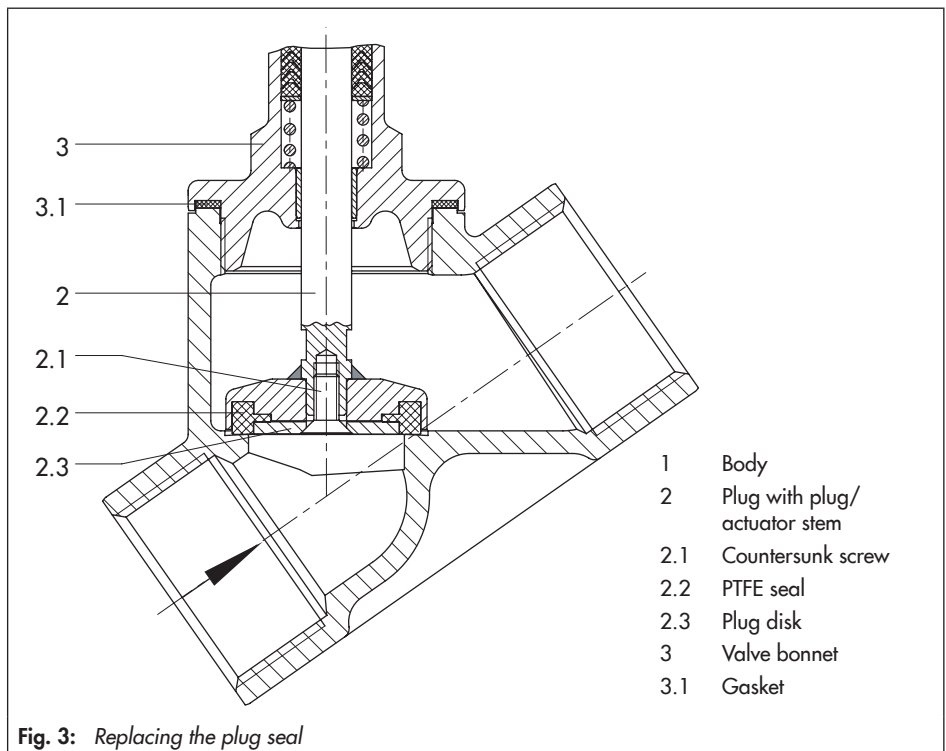

4.1 Replacing the plug seal

1. Position a 26 mm open-end wrench on the valve bonnet (3) and unscrew the entire actuator including the valve bonnet from the valve body.
A new body gasket (3.1) must be used for reassembly (step 6).
Clean the valve body, paying particular attention to the seat bore.
2. Unscrew the countersunk screw (2.1) using a 3 mm hex screwdriver, while holding the plug stem stationary at the flattened part with an 8 mm open-end wrench.
3. Remove the plug disk (2.3) and PTFE seal (2.2).
4. Clean all parts thoroughly and replace the PTFE seal with a new one.
5. Assemble in the reverse order, replacing the body gasket (3.1) on the valve bonnet (3) with a new one.

Table 1: *Tightening torques for the valve bonnet (3)*

Valve size	Tightening torque
G ½ to G ¾ DN 15 to 20	40 Nm
G 1 to G 1¼ DN 25 to 32	80 Nm
G 1½ to G 2 DN 40 to 50	160 Nm

4.2 Replacing the packing

1. Position a 26 mm open-end wrench on the valve bonnet (3) and unscrew the entire actuator including the valve bonnet from the valve body.
2. Unthread the screws (6) in an even pattern and lift off the actuator cover (7).

Fail-close (FA)

3. Lift off the spring(s) (9) and then remove the cap (10).
4. Unscrew the nut (11) from the actuator stem using a socket wrench, while holding the plug/actuator stem stationary at

Legend for Fig. 4

1	Body	4.4	Packing rings		
2	Plug with plug/ actuator stem	4.5	Spring	8.3	Washer
3	Valve bonnet	5	Actuator cover	9	Spring(s)
3.1	Gasket	5.1	O-ring	9.1	Washer
3.2	Borehole	5.2	Washer	10	Cap
4	Threaded bushing	5.3	O-ring	11	Nut
4.1	Radial shaft seal	6	Screws	12	Washer
4.2	Retaining screw	7	Actuator cover	13	Vent plug
4.3	Washer	8	Piston	13.1	Filter
		8.1	Piston ring	14	Signal pressure connection
		8.2	O-ring		

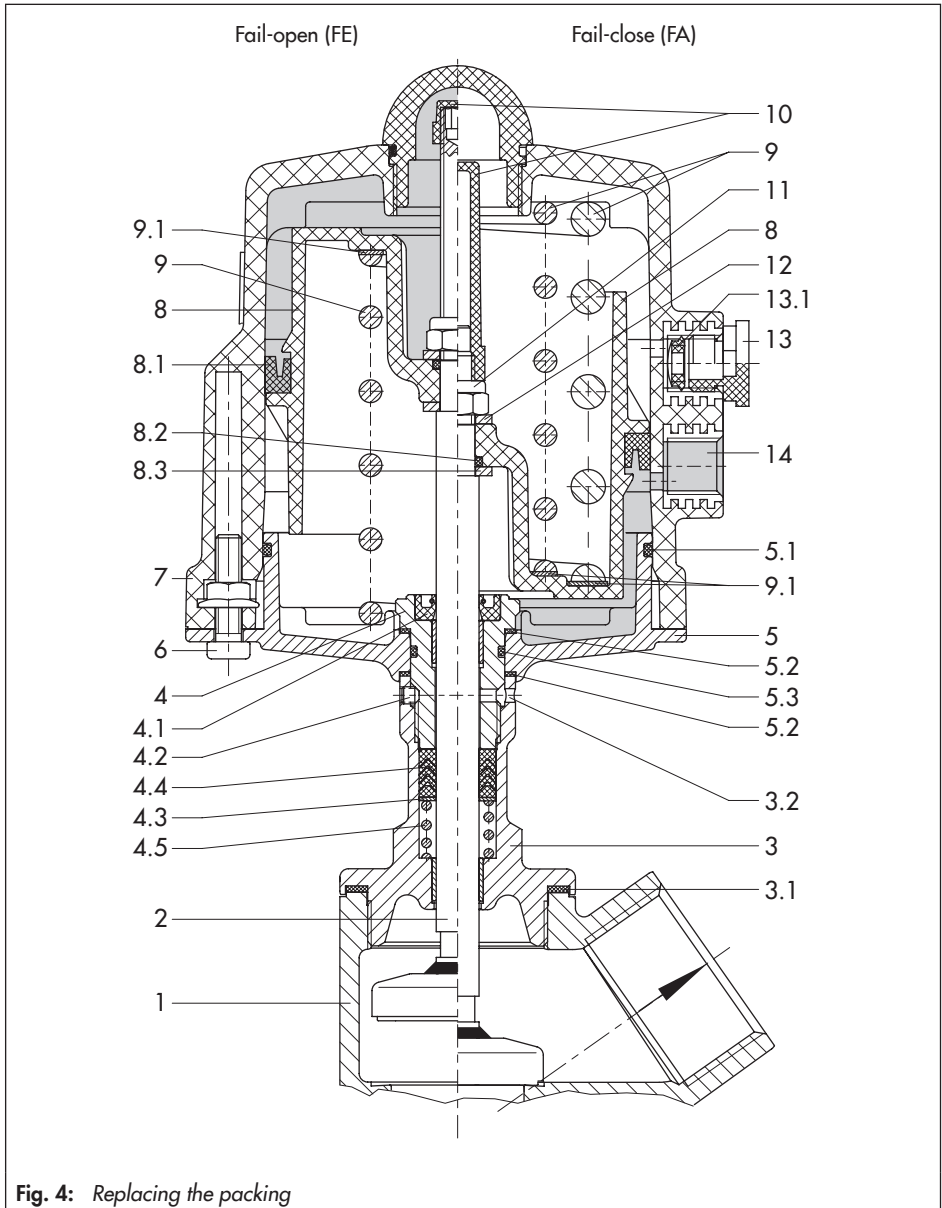

Fig. 4: Replacing the packing

the flattened part with an 8 mm open-end wrench.

5. Remove washer (12), piston (8) together with the piston ring (8.1) and washer (9.1).
6. Pull the O-ring (8.2) and washer (8.3) off the actuator stem.

Fail-open (FE)

Disassemble as previously described, but lift off the flat washer and O-ring together with the piston and then remove the washer (9.1) and spring (9).

7. Pull the actuator/plug stem down out of the valve bonnet (3).
8. Undo the retaining screw (4.2) at the side using a 2 mm hex screwdriver, then unscrew the threaded bushing (4) together with the actuator base (5) from the valve bonnet (3) using a 24 mm open-end wrench.
If necessary, press the threaded bushing out of the base and replace the top and bottom slip washer(s) (5.2) with new ones.
9. Pull the entire packing out of the valve bonnet using a suitable tool.
Carefully clean all the parts and renew the packing (4.4).
10. Slide the actuator and plug stem into the valve bonnet (3).
11. Slide the packing parts in sequence starting with the spring (4.5), washer (4.3) and packing rings (4.4) over the actuator stem into the valve bonnet.

12. Place the top slip washer (5.2) into the actuator cover. Install the O-ring (5.3) and insert the threaded bushing (4) into the actuator base (5).
13. Place the bottom slip washer (5.2) on the valve bonnet (3).
Screw the threaded bushing together with the actuator base over the actuator stem onto the valve bonnet (3).
Tighten the threaded bushing only to the point where the actuator base (5) can still rotate on the slip washers.
Screw tight the retaining screw (4.2) at the side to fix the threaded bushing in place.

14. Fail-close (FA)

First slide the washer (8.3) and the O-ring (8.2) onto the actuator stem, then put on the piston (8) together with the piston ring (8.1) and washer (12).
Insert washer (9.1) and spring (9) into the piston.

Fail-open (FE)

First place the washer (8.3) onto the actuator stem, then place the spring (9) together with the washer (9.1) onto the actuator base (5).
Slide the piston (8) with piston ring (8.1) over the actuator stem. Place the O-ring (8.2) and washer (12) on them.

15. Tighten nut (11) intended for fastening the piston, while holding the plug/actuator stem stationary at the flattened part with an 8 mm open-end wrench.
Screw on cap (10).

16. Put on actuator housing (7) and fasten tight onto the actuator base (5) by evenly tightening the screws (6).
17. Renew the body gasket (3.1). Place the valve bonnet including the actuator onto the valve body and fasten tight.
See Table 1 on page 10 for tightening torques for the valve bonnet.

4.3 Customer inquiries

Please submit the following details:

- Order number
- Type designation and model number
- Nominal size and version of the valve
- Pressure and temperature of the process medium
- Flow rate in m³/h
- Supply pressure of the actuator
- Installation drawing

5 Changing the spring force

Fail-close (FA/NC/TS) valves with the nominal sizes DN 40 and 50 (NPS 1½ and 2) and with 60 cm² actuators can be fitted with one or two actuator springs (marked on the nameplate with I or II).

By adding a spring or removing the internal spring, the permissible differential pressure and associated signal pressure can be changed.

Actuator	Version	Spring force	Quantity of springs	Signal pressure
60 cm ²	FA/NC/TS	1440 N	1	3.8 bar
		2160 N	2	5.4 bar

➔ For assembly or disassembly, proceed as described in section 4.

6 Permissible differential pressures

The specifications for the standard version have a gray background.

6.1 Version FA/NC with fail-safe position: fail-close

Valve size		DN	15 · 20	25 · 32	40 · 50
		NPS	½ · ¾	1 · 1¼	1½ · 2
Effective area	Actuator Force	Signal pressure	Δp		
30 cm ²	720 N	4.0 bar	17	6	2
60 cm ²	1440 N (one spring)	3.8 bar	40	16	6
	2160 N (two springs)	5.4 bar	–	25	10

6.2 Version FE/NO with fail-safe position: fail-open

Required actuators and signal pressures to close the valve at the specified differential pressure. Assigned according to nominal size and actuator size.

Control valve DN 15 · DN 20

Valve size	DN	15 · 20
	NPS	½ · ¾
Actuator	Signal pressure	Δp
30 cm ² Ø = 63 mm	4 bar	6
	5 bar	16
	6 bar	26
	7 bar	36
	8 bar	40
60 cm ² Ø = 90 mm	3 bar	27
	4 bar	40

Control valve DN 15 (NPS ½) · DN 20 (NPS ¾)

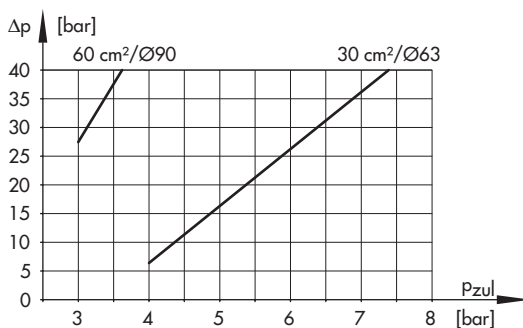

Control valve DN 25 · DN 32

Valve size	DN	25 · 32
	NPS	1 · 1¼
Actuator	Signal pressure	Δp
30 cm ² Ø = 63 mm	5 bar	6
	6 bar	10
	7 bar	14
	8 bar	18
60 cm ² Ø = 90 mm	3 bar	11
	4 bar	19
	7 bar	40

Control valve DN 25 (NPS 1) · DN 32 (NPS 1¼)

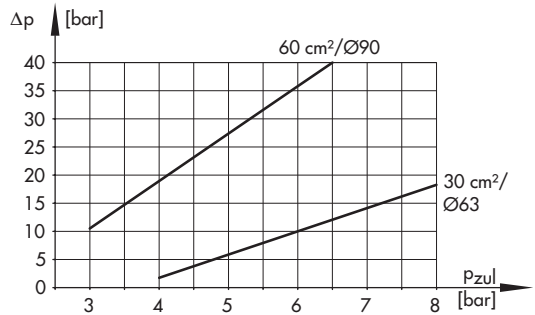

Control valve DN 40 · DN 50

Valve size	DN	40 · 50
	NPS	1½ · 2
Actuator	Signal pressure	Δp
30 cm ² Ø = 63 mm	5	2
	6	4
	7	5
	8	7
60 cm ² Ø = 90 mm	3	4
	4	7
	5	11
	6	14
	7	18
	8	21

Control valve DN 40 (NPS 1½) · DN 50 (NPS 2)

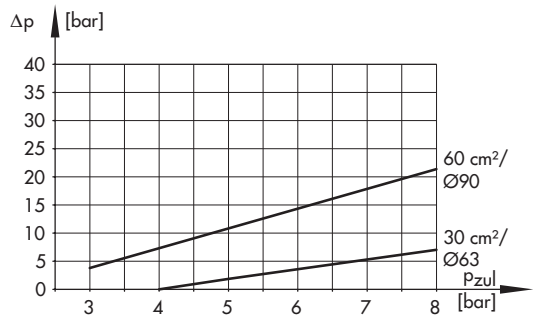



SAMSON AG · MESS- UND REGELTECHNIK
Weismüllerstraße 3 · 60314 Frankfurt am Main, Germany
Phone: +49 69 4009-0 · Fax: +49 69 4009-1507
samson@samson.de · www.samson.de

EB 8139 EN

2017-06-28 · English