

Pneumatic Butterfly Valve Type 3335/AT and Type 3335/3278



Fig. 2 · Type 3335/AT



Fig. 1 · Type 3335/3278 with attached positioner

Mounting and operating instructions

EB 8220 EN

Edition November 2000

Contents		Page
1.	Design and principle of operation	4
2.	Installation	6
2.1	Assembling butterfly valve and rotary actuator	6
2.1.1	Type 3335/AT	6
2.1.2	Type 3335/3278	6
2.2	Mounting position	8
2.3	Loading pressure connection	8
3.	Operation	8
3.1	Changing the fail-safe action	8
4.	Customer inquiries	9



- ▶ *Assembly, start-up and operation of this pneumatic butterfly control valve may only be performed by trained personnel familiar with this product. According to these mounting and operating instructions, trained personnel refers to individuals who are able to judge the work they are assigned to and recognize potential hazards due to their specialized training, their knowledge and experience as well as their knowledge of the applicable standards.*
- ▶ *Any hazards which could be caused at the control valve by the process medium, the signal pressure, or moveable parts, must be prevented by means of appropriate measures. Moreover, it must be ensured that the control valve is only used in applications where operating pressure and temperatures do not exceed the operating values which are based on the valve sizing data submitted with the order.*
- ▶ *Proper shipping and appropriate storage are assumed.*

1. Design and principle of operation

The pneumatic butterfly control valve consists of the Type 3335 Butterfly Valve and either the Type Pfeiffer AT or Type 3278 Pneumatic Rotary Actuator.

It is primarily designed for on-off services in process engineering and plants with industrial requirements.

It can also be used for continuous control applications in the rotation range from 25° to 60°.

When the process medium flows through the butterfly valve, the signal pressure acting on the rotary actuator determines the position (opening angle) of the disc (4) and therefore the flow rate across the open area between the disc and the valve body (2).

The actuator motion is transmitted from the actuator shaft to the disc shaft of the butterfly valve by means of an adapter (9) with a square end or a feather key.

Fail-safe action:

The fail-safe action of the control valve, which becomes effective when the supply air (signal pressure) fails, is determined in Type 3335/AT (Type SRP single-acting version) by the version used and in Type 3335/3278 by how the rotary actuator is mounted to the valve.

"Butterfly valve CLOSED without supply air"

The actuator springs close the butterfly valve when the signal pressure is reduced or the supply air fails.

When the signal pressure increases, the butterfly valve is opened, acting against the spring force.

"Butterfly valve OPEN without supply air"

The actuator springs open the butterfly valve when the signal pressure is reduced or the supply air fails.

When the signal pressure increases, the butterfly valve is closed, acting against the spring force.

The Type DAP Double-acting Rotary Actuator has no springs. A defined final position is not reached when the supply air fails.

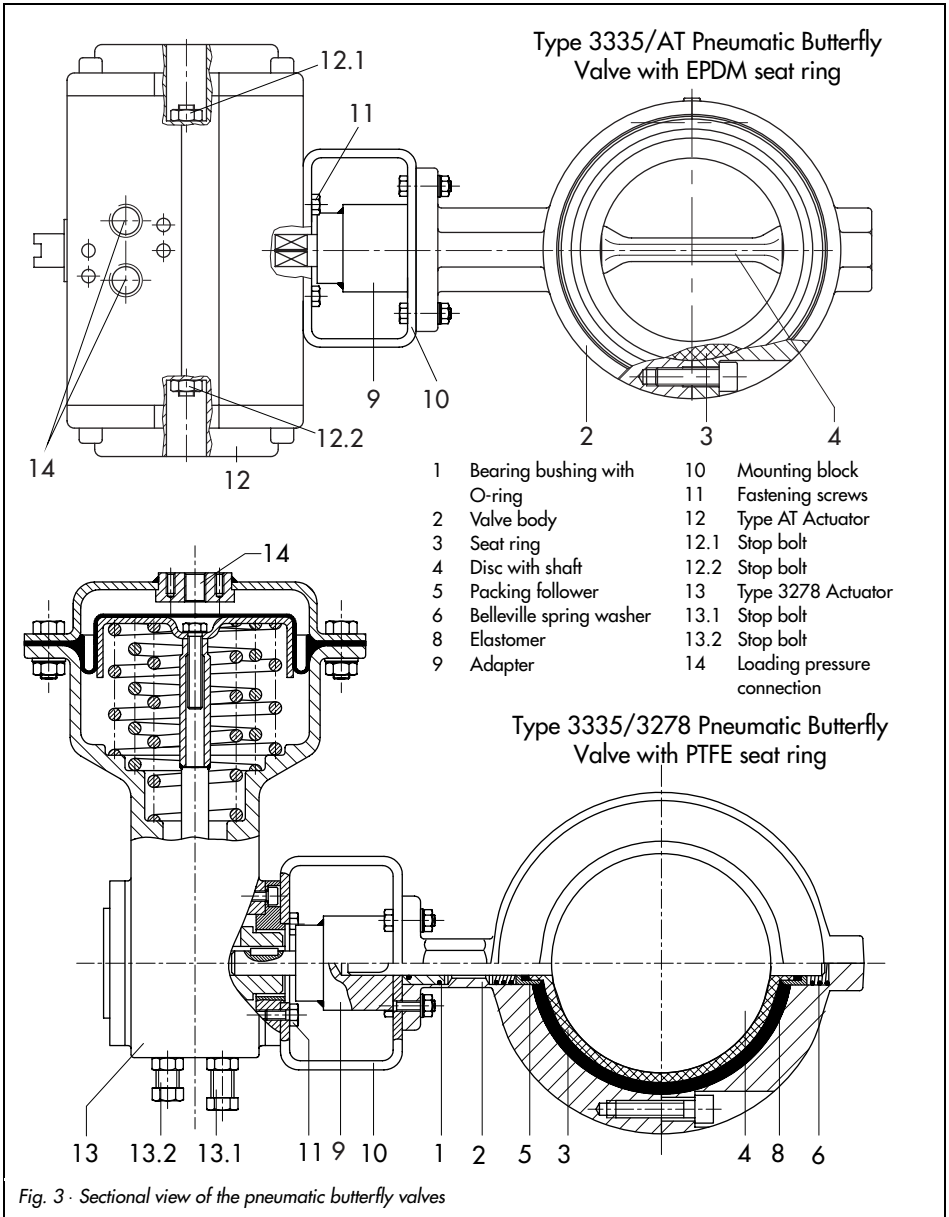

2. Installation

2.1 Assembling butterfly valve and rotary actuator

2.1.1 Type 3335/AT

SRP Version

NOTE

In assembled control valves, the spring return mechanism of a standard actuator version (SRP = single-acting with spring return mechanism) causes the butterfly valve to close clockwise when there is no signal pressure.

If you require another direction of rotation or a double-acting actuator (DAP = double-acting without spring return mechanism), please specify the desired version on ordering the actuator.

If the butterfly valve and the actuator have not been assembled by the manufacturer, note that due to the square-ended disc shaft adapter, the rotary actuator can be mounted onto the butterfly valve in four different positions at 90°, 180°, 270° or 360° in such a way that it either faces horizontally or vertically toward the butterfly valve allowing to meet the installation requirements. In order to assemble the butterfly valve and the actuator, proceed as follows:

Butterfly valve is to be CLOSED without supply air

1. Move the disc (4) of the butterfly valve into its closed position (0° opening angle).

2. Slide the actuator over the square-ended adapter (9) of the disc shaft into the desired position and screw it onto the mounting block (10) with four fastening screws (11).
3. Apply a signal pressure to the loading pressure connection which corresponds to the number of springs in the actuator (see nameplate).
4. Screw in the stop bolt (12.1) until the disc reaches an opening angle of 90°.
5. Secure the stop bolt with its lock nut.

Butterfly valve is to be OPEN without supply air

1. Move the disc (4) of the butterfly valve into its open position (0° opening angle).
2. Slide the actuator over the square-ended adapter (9) of the disc shaft into the desired position and screw it onto the mounting block (10) with four fastening screws (11).
3. Apply a signal pressure to the loading pressure connection (12) which corresponds to the number of springs in the actuator (see nameplate).
4. Screw in the stop bolt (12.2) until the butterfly valve is completely closed.
5. Secure the stop bolt with its lock nut.

2.1.2 Type 3335/3278

If the butterfly valve and the actuator have not been assembled by the manufacturer, note the following points:

For fail-safe action "butterfly valve CLOSED without supply air", the butterfly valve must be attached to flange 2 of the actuator. And for fail-safe action "butterfly valve OPEN

without supply air" the butterfly valve must be mounted to flange 1 of the actuator. "1" or "2" is indicated on the corresponding side of the actuator case.

Due to the four grooves of the actuator shaft and the feather key of the disc shaft adapter, the rotary actuator can be mounted onto the butterfly valve in four different positions at 90°, 180°, 270° or 360° in such a way that it either faces horizontally or vertically toward the butterfly valve allowing to meet the installation requirements.

In order to assemble the butterfly valve and the actuator, proceed as follows:

Butterfly valve is to be CLOSED without supply air

1. Completely loosen both stop bolts (13.1 and 13.2) of the rotary actuator, then screw in the stop bolt (13.2) until the grooves of the actuator shaft are aligned with the actuator axis horizontally and vertically.
2. Move the disc (4) of the butterfly valve into its closed position (0° opening angle).
3. Slide the actuator over the adapter (9) of the disc shaft and screw it onto the mounting block (10) with four fastening screws (11).
4. Loosen the stop bolt (13.2) again.
5. Apply a signal pressure to the loading pressure connection which corresponds to the lower range value of the spring range (see nameplate).
6. Screw in the stop bolt (13.2) until the butterfly valve is completely closed.
7. Apply a signal pressure at the loading pressure connection which corresponds to the upper range value of the spring range.

8. Screw in the stop bolt (13.1) until the disc reaches an opening angle of 90°.
9. Secure both stop screws with their lock nuts.

Butterfly valve is to be OPEN without supply air

1. Loosen both stop bolts (13.1 and 13.2) of the rotary actuator, then screw in the stop bolt (13.2) until the grooves of the actuator shaft are aligned with the actuator axis horizontally and vertically.
2. Move the disc (4) of the butterfly valve into its open position (90° opening angle).
3. Slide the actuator over the adapter (9) of the disc shaft and screw it onto the mounting block (10) with four fastening screws (11).
4. Loosen the stop bolt (13.1) again.
5. Apply a signal pressure to the loading pressure connection which corresponds to the upper range value of the spring range (see nameplate).
6. Screw in the stop bolt (13.1) until the butterfly valve is completely closed.
7. Apply a signal pressure to the loading pressure connection which corresponds to the lower range value of the spring range.
8. Screw in the stop bolt (13.1) until the disc reaches an opening angle of 90°.
9. Secure both stop bolts with their lock nuts.

2.2 Mounting position

The butterfly valve can be installed into a pipeline either vertically or horizontally, however, the following points must be observed:

Install the butterfly valve into the pipeline so that the lower half of the disc opens in the direction of the flow. This helps to prevent dirt deposits from accumulating and blocking the opening of the butterfly valve.

NOTE

When installing the butterfly valve between the pipeline flanges, do not use any flange seals since the seat ring (3) of the butterfly valve also seals the flanges. Moreover, make sure that the disc does not extend beyond the valve body. For this purpose, move the disc into its closed position first.

When tightening the flange bolts, make certain that the flanges are centered and tightened uniformly to prevent the lining from being damaged.

The disc must be able to move freely after installation in the pipeline is completed.

2.3 Loading pressure connection

The loading pressure connection of rotary actuators is a G1/4 female threaded bore. In compliance with VDE/VDE 3845 guidelines, this type of connection also allows the connection of a solenoid valve, e.g. Type 3963.

If you want to install a SAMSON positioner, you also need the accessories required for the connection.

3. Operation

3.1 Changing the fail-safe action

After delivery, the fail-safe action of the Type 3278 Actuator can be changed from "Butterfly valve CLOSED without supply air" to "Butterfly valve OPEN without supply air" and vice versa. For this purpose, the attachment side of the rotary actuator must be changed from actuator flange 2 to 1 or correspondingly vice versa. In the Type AT Version SRP Actuator, the pistons must be reversed to change the fail-safe action.

NOTE

Refer to the mounting and operating instructions of the respective rotary actuator for further details, for example about changing the spring range to obtain other actuator torques.

4. Customer inquiries

Should you have any questions regarding the control valve, please submit the following details:

- ▶ Order number
(indicated on the nameplate)
- ▶ Type, model number, nominal size and control valve version
- ▶ Pressure and temperature of the process medium
- ▶ Flow rate in m³/h
- ▶ Signal pressure range (spring range of actuator)
- ▶ Installation drawing

Dimensions

For details about dimensions and weights, please refer to Data Sheet T 8220 EN.



SAMSON AG · MESS- UND REGELTECHNIK
Weismüllerstraße 3 · D-60314 Frankfurt am Main
Telefon (0 69) 4 00 90 · Telefax (0 69) 4 00 95 07
Internet: <http://www.samson.de>

EB 8220 EN

S/C 2000-12