



V2001-IP Control Valve
Type 3372-0511/0531 Electropneumatic Actuator with Type 3321 Valve

Mounting and Operating Instructions

EB 8313-1 EN

Edition July 2013

Definition of signal words



DANGER!

Hazardous situations which, if not avoided, will result in death or serious injury



WARNING!

Hazardous situations which, if not avoided, could result in death or serious injury



NOTICE

Property damage message or malfunction



Note:

Additional information



Tip:

Recommended action

1	Safety instructions	4
2	Design and principle of operation	6
2.1	Technical data	8
3	Mounting on the valve.....	9
4	Connections	10
4.1	Pneumatic connections.....	10
4.2	Electrical connection.....	12
5	Checking and adjusting zero and span.....	13
5.1	Actuator with "actuator stem extends" fail-safe action	13
5.2	Actuator with "actuator stem retracts" fail-safe action	15
6	Deactivating and activating the tight-closing function	16
7	Version with limit switch - adjustment.....	17
8	Customer inquiries	18
9	Dimensions	18

1 Safety instructions



- The actuator is to be mounted, started up or operated only by trained and experienced personnel familiar with the product.
- According to these mounting and operating instructions, trained personnel refers to individuals who are able to judge the work they are assigned to and recognize possible dangers due to their specialized training, their knowledge and experience as well as their knowledge of the applicable standards.
- Explosion-protected versions of this actuator are to be operated only by personnel who has undergone special training or instructions or who is authorized to work on explosion-protected devices in hazardous areas.
- Any hazards that could be caused in the mounted valve by the process medium, the operating pressure, the signal pressure or by moving parts are to be prevented by taking appropriate precautions.
- If inadmissible motions or forces are produced in the pneumatic actuator as a result of the supply pressure level, it must be restricted using a suitable supply pressure reducing station.
- The actuator springs are preloaded. A special tool is required to open the actuator. Do not open the actuator.
- Proper shipping and storage are assumed.



Note:

Devices with a CE marking fulfill the requirements of the Directives 2014/34/EU and 2014/30/EU. The Declaration of Conformity is available on request.

2 Design and principle of operation

The actuators are used for attachment to Series V2001 Valves, such as Type 3321, Type 3323, Type 3531, Type 3535 and Type 3214 (DN 65 to 100) as well as Type 3260 Valve (DN 65 and 80).

The actuators mainly consist of two diaphragm cases, a rolling diaphragm and springs. They are fitted with an i/p converter and a pneumatic control system for throttling service. The converter and the control system are installed in the bottom diaphragm case of actuators with "actuator stem extends" fail-safe action and in the top diaphragm case of actuators with "actuator stem retracts" fail-safe action.

The electric control signal issued by the controller as a reference variable from 4 to 20 mA is transmitted to the electropneumatic converter where it is converted into a proportional pressure signal. The pressure signal creates a force that acts on the measuring diaphragm (11). This force is then compared with the force of the range spring (13). The movement of the measuring diaphragm is transmitted by the lever (12) to the force switch (15), and finally a corresponding signal pressure is produced.

Changes in the input signal or the valve position cause a change in the actuator stem position, corresponding to the reference variable.

The actuator is fastened to the valve bonnet using a central nut (Form B attachment, see Fig. 1).

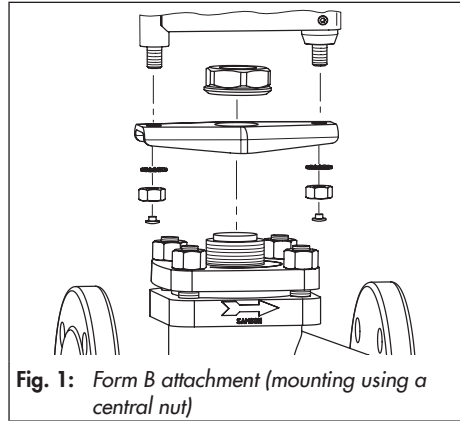

Fig. 1: Form B attachment (mounting using a central nut)

Tight-closing function

The electropneumatic actuator is completely filled with air or vented as soon as the reference variable falls below or exceeds a certain value.

Actuator stem extends

Deactivation function that becomes active when the signal falls below the switching point of 4.08 mA: the actuator is fully vented, causing a globe valve to close tightly. In three-way valves, port **B** is closed when the valve is used for mixing service and port **A** is closed when the valve is used for diverting service.

Actuator stem retracts

Activation function that becomes active when the signal exceeds the switching point of 19.95 mA: the actuator is filled with air, causing a globe valve to close tightly. In three-way valves, port **B** is closed when the valve is used for mixing service and port **A** is closed when the valve is used for diverting service.

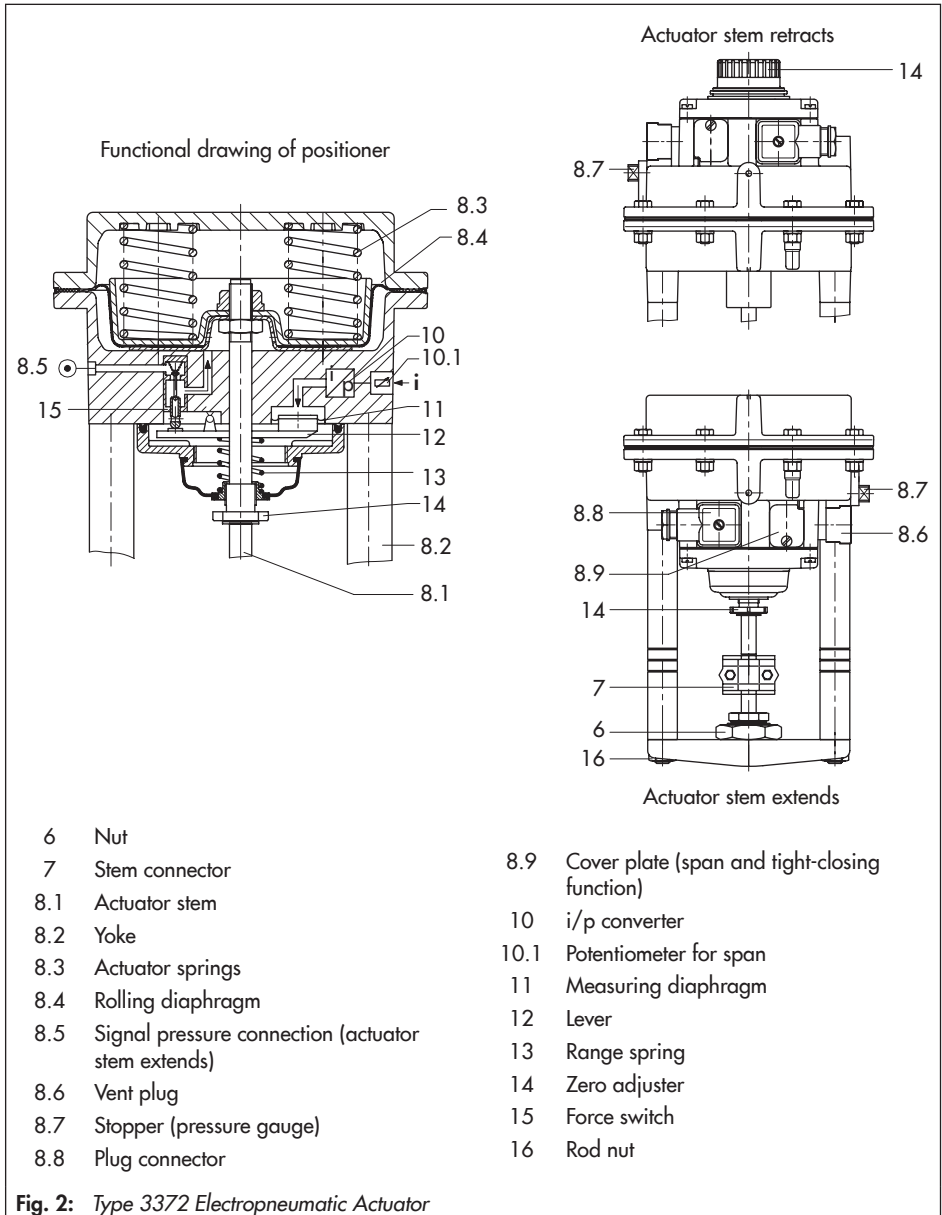

- | | | | |
|-----|--|------|---|
| 6 | Nut | 8.9 | Cover plate (span and tight-closing function) |
| 7 | Stem connector | 10 | i/p converter |
| 8.1 | Actuator stem | 10.1 | Potentiometer for span |
| 8.2 | Yoke | 11 | Measuring diaphragm |
| 8.3 | Actuator springs | 12 | Lever |
| 8.4 | Rolling diaphragm | 13 | Range spring |
| 8.5 | Signal pressure connection (actuator stem extends) | 14 | Zero adjuster |
| 8.6 | Vent plug | 15 | Force switch |
| 8.7 | Stopper (pressure gauge) | 16 | Rod nut |
| 8.8 | Plug connector | | |

Fig. 2: Type 3372 Electropneumatic Actuator

2.1 Technical data

Actuator area	120 cm²			
Rated travel	15 mm			
Tight-closing function	Stem retracts (FE)	Stem extends (FA)	Stem retracts (FE)	Stem extends (FA)
Bench range	0.4 to 1.4	1.4 to 2.3	1.4 to 2.3	2.1 to 3.3
Supply pressure	Max. 6 bar	Max. 4 bar	Max. 4 bar	Max. 6 bar
Reference variable	4 to 20 mA · Minimum current 3.6 mA Load impedance $\leq 6 \text{ V}$ (300 Ω at 20 mA)			
Adjusting the span	25 % of travel range using potentiometer			
Operating direction	Increasing/increasing, fixed			
Characteristic	Linear · Deviation from terminal-based conformity $\leq 2 \%$			
Hysteresis	$\leq 1 \%$			
Variable position	$\leq 7 \%$			
Tight-closing function (can be activated by a jumper)	Deactivation at $\leq 4.08 \text{ mA}$ (stem extends) Activation at $\geq 19.95 \text{ mA}$ (stem retracts) Switching accuracy: 0.14 mA			
Air consumption in steady state	w = 100 %: 6 bar $\leq 200 \text{ l}_n/\text{h}$ 4 bar $\leq 160 \text{ l}_n/\text{h}$			
Temperature range	-30 to +70 °C			
Degree of protection	IP 54 ¹⁾ Optionally type of protection II 2G Ex ia IIC T6			
Electrical connection	Cable socket according to DIN EN 175301-803, black polyamide, 8 to 10 mm clamping range Screw terminals for up to 1.5 mm ² wire cross-section			
Weight	3.7 kg			
Limit switch	Type 4744-2			
Type of protection	Flameproof enclosure II 2G Ex db IIC T6-T5			
Permissible load	AC voltage: 250 V/5 A DC voltage: 250 V/0.4 A			
Permissible ambient temperature	-20 to +60 °C			
Degree of protection	IP 66			
Weight (approx. kg)	0.4			

¹⁾ IP 65 if the vent plug is replaced by a filter check valve (order no. 1790-7408)

3 Mounting on the valve



NOTICE

Do not unscrew the rod nuts (16) of the rod-type yoke.

Actuators with "actuator stem extends" fail-safe action

Apply a signal pressure to actuators before mounting them onto a valve to allow the actuator stem to retract slightly.

If no signal pressure or electric control signal is available during the mounting procedure, tighten the hexagon nut (6) against the force of the preloaded springs using a hexagonal wrench with width across flats (SW 36).

Actuators with "actuator stem retracts" fail-safe action

Air only needs to be applied to actuators for attaching the stem connector clamps.

The reason for this is that in three-way valves, for example, the plug stem might not reach the actuator stem after being pulled out of the valve body. If this is the case, a signal pressure must be applied to the top diaphragm chamber until the plug stem and actuator stem come into contact so that the stem connector can be mounted.

Mounting by applying a signal pressure or electric control signal



Note:

Apply a pressure of approx. 3 bar to the supply connection and additionally connect a control signal of approx. 10 mA to retract the actuator stem.

1. Unscrew the hexagon nut (6) from the valve bonnet and place the actuator on the valve bonnet with its stem retracted by applying signal pressure.
2. Align the actuator and secure the hexagon nut (SW 36) applying a tightening torque of min. 150 Nm.
3. Pull up the plug stem (3) until it contacts the actuator stem.
4. Place the stem connector clamps in position and screw tight using the fastening screws.

4 Connections

4.1 Pneumatic connections

The pneumatic connections are designed as a bore with G ¼ thread. Customary fittings for metal tubing or plastic hoses can be used.



NOTICE

- Make sure the supply air is dry as well as free of oil and dust.
- Read the maintenance instructions for upstream pressure reducing stations.
- Blow through all air pipes and hoses thoroughly before connecting them.



Note:

The required supply air pressure depends on the bench range and the actuator's operating direction (fail-safe action). The bench range is written on the nameplate. The direction of action is marked FA or FE, or by a symbol.

- Connect the supply air to the supply connection.

Actuator stem extends (FA)

(Type 3372 -x51x and Type 3372-x53x)

Fail-close (for globe and angle valves):

Required supply pressure = Upper bench range value + 0.5 bar

Actuator stem retracts (FE)

(Type 3372-x52x and Type 3372-x54x)

Fail-close (for globe and angle valves):

The signal pressure must be high enough so that the control valve closes tightly even against the upstream pressure in the plant.

For the required supply pressure for a tight-closing valve, refer to the mounting and operating instructions of the mounted valve, or roughly calculate as follows, using the maximum signal pressure p_{stmax} :

$$p_{\text{stmax}} = F + \frac{d^2 \cdot \pi \cdot \Delta p}{4 \cdot A} \text{ [bar]}$$

d = Seat diameter [cm]

Δp = Differential pressure across the valve [bar]

A = Actuator diaphragm area [cm²]

F = Upper bench range value of the actuator

If there are no specifications, calculate as follows:

Required supply pressure = Upper bench range value + 1 bar

Signal pressure gauges

To monitor the signal pressure, a pressure gauge with G $\frac{1}{8}$ thread can be screwed into the diaphragm chamber in place of the stopper (8.7).

**WARNING!**

Only shut down the control valve over the reference variable. Do not disconnect the supply air to shut down the valve.

4.2 Electrical connection

1. Unthread the fastening screw (1) of the plug connector and remove the plug connector from the female connector on the actuator housing.



NOTICE

Do not remove the female connector from the actuator housing. The correct ground connection can only be guaranteed when it is in its original position.

2. Pull the fastening screw (1) out of the plug connector and remove the rubber seal (5).

3. Lever the plug insert (3) out of the plug connector case (2) at the opening (4) using a screwdriver.
4. Connect the wires transmitting the control signal through the cable gland (6) of the plug connector case to the terminals of the insert which are marked 1 (+), 2 (-) and to its ground terminal. Secure them with screws.
5. Reinstall the insert (3) in the plug connector case. Make sure that the cable gland (6) points to the desired direction (the plug connector case can be turned by 90° around the insert to point to all four directions).
6. Put on the rubber seal (5).

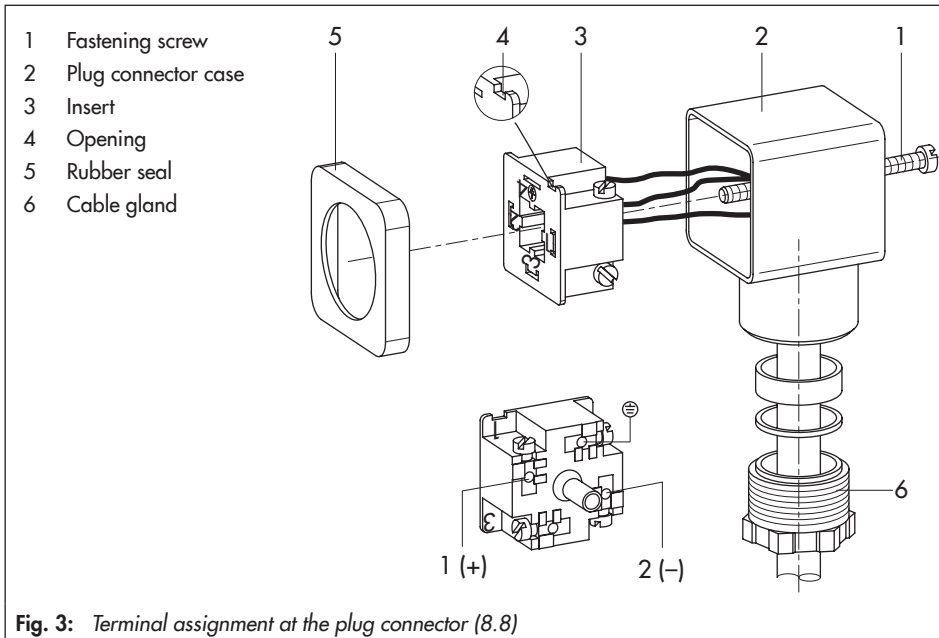

7. Plug the plug connector back in the actuator housing and secure with fastening screw (1).

5 Checking and adjusting zero and span

! **NOTICE**
Only make adjustments on the mounted valve.

Zero and span are adjusted to determine the starting point and the upper range value of the actuator.

When the control signal (reference variable) issued by the controller changes from 4 to 20 mA, the control valve must correspondingly pass through its entire travel range from 0 to 100 %.

Zero is always based on the closed position of the valve.

For example, in a fail-close globe valve with (Type 3372-(0/1)511 and 3372-(0/1)531 Actuator with "actuator stem extends" fail-safe action), the zero (starting point) must be set to 4 mA and the upper range value to 20 mA.

For example, in a fail-open globe valve with (Type 3372-(0/1)521 and 3372-(0/1)541 Actuator with "actuator stem retracts" fail-safe action), the zero (starting point) must be set to 20 mA and the upper range value to 4 mA.

i **Note:**
Zero and span of the electropneumatic actuator are calibrated to match the rated travel by SAMSON.

We recommend, however, checking zero after the actuator has been mounted to the valve as described below:

1. Connect an ammeter to the control signal input and apply air to the supply input.
2. Undo the fastening screw and push the cover plate (8.9) aside.
3. Pull the jumper from the pins to deactivate the tight-closing function.

Zero is adjusted at the adjuster (14) and the upper range value at the potentiometer for span (10.1).

! **NOTICE**
Any span adjustment results in a shift of zero. Therefore, the zero point must be readjusted after span adjustment.

5.1 Actuator with "actuator stem extends" fail-safe action

Zero (starting point)

1. Set the input signal at the ammeter to 4 mA
2. Turn the zero adjuster (14) until the plug stem just starts to move from its initial position.

3. Reduce the input signal to 0 mA and slowly increase it again. Check whether the plug stem starts to move at 4 (+0.1) mA.
4. Correct deviations at the zero adjuster (14).

Turning the adjuster clockwise causes the valve to leave its end position earlier, whereas turning it counterclockwise delays the valve leaving its end position.

Upper range value (span)

5. Once the starting point has been set, increase the input signal to 20 mA at the ammeter.

At exactly 20 (-0.1) mA, the plug stem must have passed through its entire rated travel range of 100 %.

6. Adjust the potentiometer for span (10.1) until the upper range value is correct.
Turn the potentiometer clockwise to increase the travel and counterclockwise to reduce it.
7. After the correction has been completed, reduce the input signal and slowly increase it again. Check the starting point (4 mA) and the upper range value (20 mA).
8. Repeat the correction procedure until both values are correct.
9. Plug jumper back on the pins again to activate the tight-closing function.

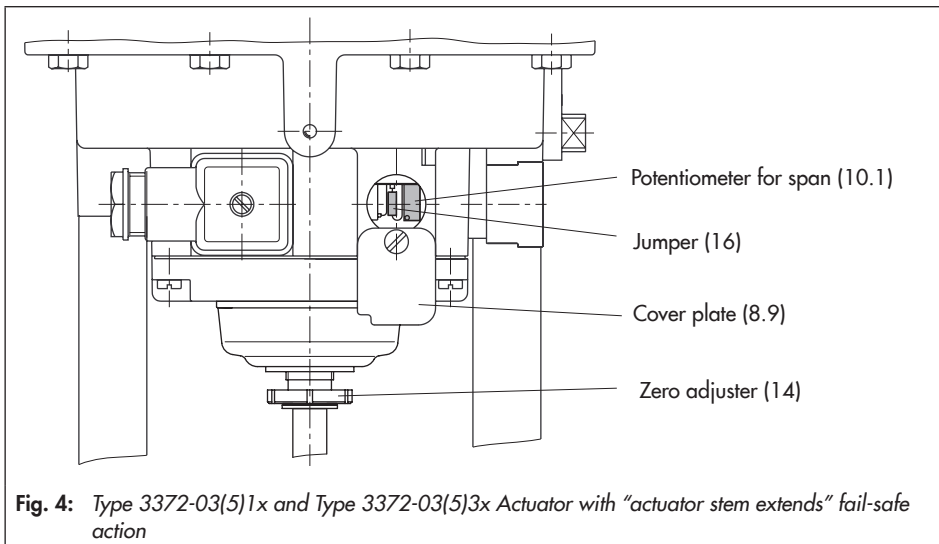

Fig. 4: Type 3372-03(5)1x and Type 3372-03(5)3x Actuator with "actuator stem extends" fail-safe action

5.2 Actuator with "actuator stem retracts" fail-safe action

Zero (starting point)

1. Set the input signal at the ammeter to 20 mA
2. Remove the protective cap and turn the zero adjuster (14) until the plug stem just begins to move from its initial position.
3. Increase the input signal and slowly reduce it again to 20 mA. Check whether the plug stem starts to move at 20 mA.
4. Correct deviations at the zero adjuster (14). Turning the adjuster clockwise causes the valve to leave its end position earlier, whereas turning it counterclockwise delays the valve leaving its end position.

Upper range value (span)

5. Once the starting point has been set, increase the input signal to 4 mA at the ammeter.
At an upper range value of 4 mA, the plug stem must have passed through its entire rated travel range of 100 %.
6. Adjust the potentiometer for span (10.1) until the upper range value is correct.
Turn the potentiometer clockwise to increase the travel and counterclockwise to reduce it.
7. After the correction has been completed, increase the input signal again. Check the starting point (20 mA) and the upper range value (4 mA).
8. Place the protective cap back on the zero adjuster.

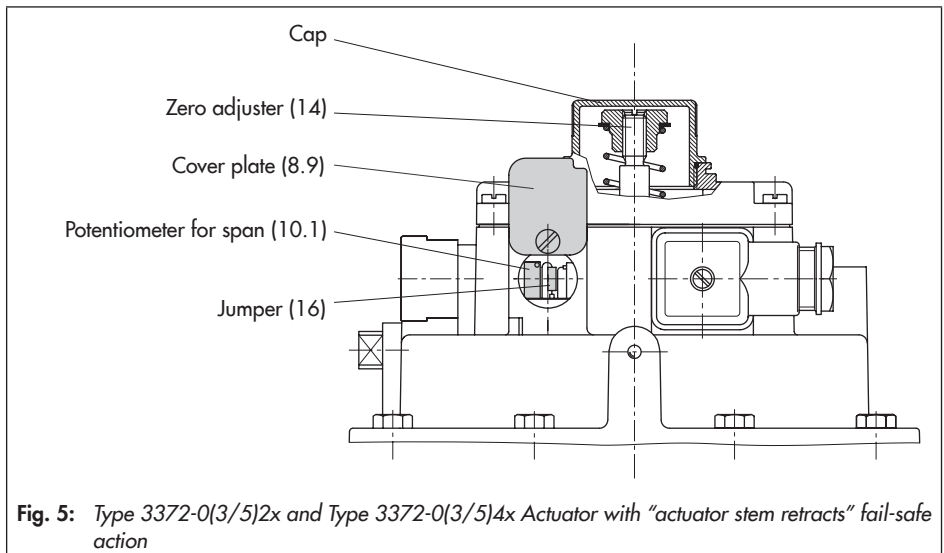

Fig. 5: Type 3372-0(3/5)2x and Type 3372-0(3/5)4x Actuator with "actuator stem retracts" fail-safe action

9. Plug jumper back on the pins again to activate the tight-closing function.

6 Deactivating and activating the tight-closing function

The electronic deactivation and activation of the tight-closing function integrated in the actuator ensures tight closing of the control valve whenever the control signal exceeds or falls below the switching point.

Actuator stem extends

If the reference variable falls below the switching point of $4.08 \text{ mA} \pm 0.14 \text{ mA}$ hysteresis, the actuator is fully vented to close a globe valve.

Actuator stem retracts

If the reference variable exceeds the switching point of $19.95 \text{ mA} \pm 0.14 \text{ mA}$ hysteresis, the actuator is fully filled with air to close a globe valve.



Note:

The tight-closing function is activated when the jumper is plugged in. Remove the jumper to deactivate this function.

7 Version with limit switch - adjustment

1. Undo the clamps of the stem connector on the valve. Replace the front clamp with the clamp including the U-bolt from the accessories.
2. Move the valve to the switching point at which the contact is to be activated.
3. Position the clamping plate on the rod-type yoke at the point where the lever rests on the bracket of the stem connector.
4. Align clamping plate and secure it in place.
5. Connect the wiring according to the label on the clamping plate:
Black (BK)/blue (BU) > contact open
Black (BK)/brown (BN) > contact closed
6. Move the valve up and down close to the required switching position and make any fine adjustments to the exact switching point using the adjustment screw.

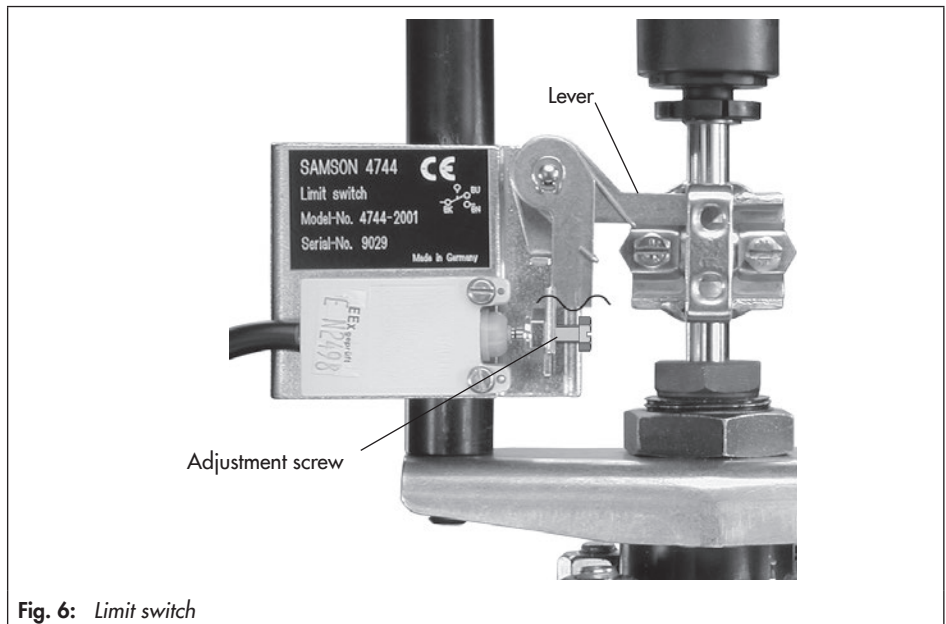

Fig. 6: Limit switch

8 Customer inquiries

Please submit the following details:

- Type designation
- Bench range (spring range) of actuator

9 Dimensions

Refer to Fig. 7 for the most important dimensions.

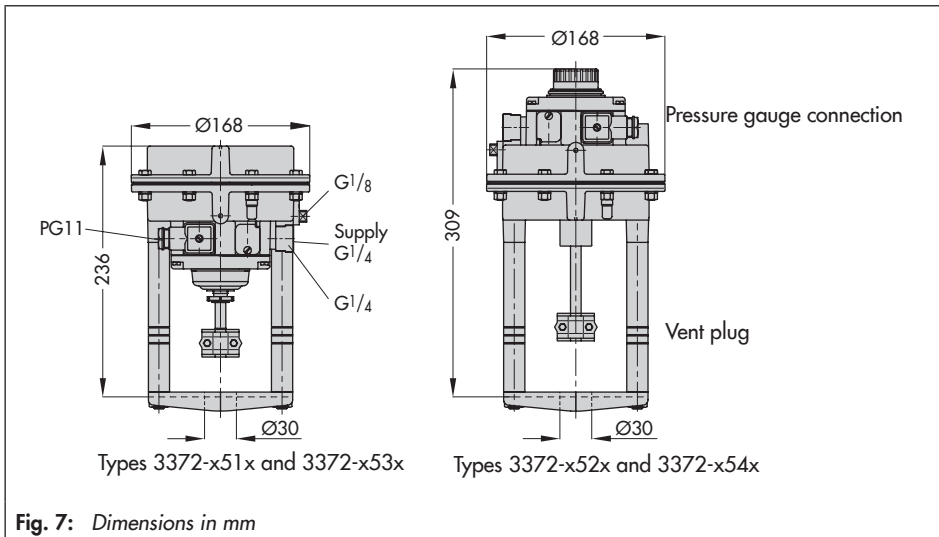

TRANSLATION**EC TYPE EXAMINATION CERTIFICATION**

- (1) Equipment and Protective Systems Intended for Use in Potentially Explosive Atmospheres – **Directive 94/9/EC**
- (2) EC Type Examination Certificate Number
PTB 99 ATEX 2049
- (3) Equipment: Model 3372 /JP Actuator
- (4) Manufacturer: SAXSON AG
- (5) Address: Weismüllerstr. 3, D-60314 Frankfurt
- (6) This equipment and any acceptable variation thereof are specified in the schedule to this certificate and the documents referred to therein.
- (7) The Physikalisch-Technische Bundesanstalt, certified body number: 01 102 in accordance with Article 9 of the Council Directive 94/9/EC of 23 March 1994, certifies that this equipment has been found to comply with the Essential Health and Safety requirements relating to the design and construction of equipment and systems intended for use in potentially explosive atmospheres given in Annex II to the Directive.

The examination and test results are recorded in confidential report.

(9) Compliance with the Essential Health and Safety Requirements has been assured by compliance with

EN 50014: 1997
EN 50020: 1994

(10) If the sign "X" is placed after the certificate number, it indicates that the equipment is subject to special conditions for safe use specified in the schedule to this certificate.

(11) According to the Directive 94/9/EC, this EC TYPE EXAMINATION CERTIFICATE relates only to the design and construction of the specified equipment. If applicable, further requirements of this Directive apply to the manufacture and supply of the equipment.

Platf.doc

(12) The marking of the equipment shall include the following:



Zertifizierungsstelle Explosionsschutz Braunschweig, 06 July 1999
By order

(Signature) (Seal)

Dr. Ing. U. Johannsmeyer
Regierungsdirktor

EC Type Examination Certificate may only be transferred to another certified body if the original certificate is cancelled.
This EC Type Examination Certificate may only be reissued in its entirety and without any changes, additions, deletions or omissions.
Extracts or changes shall require the prior approval of the Physikalisch-Technische Bundesanstalt.

Physikalisch-Technische Bundesanstalt, Bundesallee 100, D-38116 Braunschweig

Platf.doc

(13) **Schedule**(14) **EC TYPE EXAMINATION CERTIFICATE No. PTB 99 ATEX 2049**(15) **Description of Equipment**

The Model 3372-1 I/P Actuator is intended for attachment to control valves thus supplementing them to become pneumatic or electro-pneumatic control valves. They will be used inside and outside of hazardous areas.

The Model 3372-1 I/P Actuator is a passive two-terminal network that may be connected to ess certified intrinsically safe circuits unless the permissible maximum values of U_i , I_i and P_i are exceeded.

Electrical connection is made via plug connectors or cable entries.

The relation between temperature classification, permissible maximum ambient temperature ranges, and the maximum short-circuit currents is specified in the tables below.

With Model 6112 I/P Converter

Temperature class	Permissible ambient temperature range	Maximum short-circuit current
T6	-20 °C ... 60 °C	
T5	-20 °C ... 70 °C	85 mA
T4	-20 °C ... 80 °C	
T6	-20 °C ... 55 °C	
T5	-20 °C ... 70 °C	100 mA
T4	-20 °C ... 80 °C	

With Model 6109 I/P Converter

Temperature class	Permissible ambient temperature range	Maximum short-circuit current
T6	-20 °C ... 60 °C	
T5	-20 °C ... 70 °C	85 mA
T4	-20 °C ... 80 °C	
T5	-20 °C ... 70 °C	100 mA
T4	-20 °C ... 80 °C	

PTB1.doc

Electrical data

Power supply

Type of protection: Intrinsic safety Ex ia IIC only for connection to a certified intrinsically safe circuit.

Maximum values:

$U = 28 \text{ V}$
 $I = 100 \text{ mA}$ or 85 mA
 $P = 0,7 \text{ W}$

Linear Characteristic

negligible

C

negligible, L

(16) **Report PTB Ex 99-28462**(17) **Special conditions for safe use**

Not applicable

(18) **Essential Health and Safety Requirements**

In compliance with the standards specified above.

Zertifizierungsstelle Explosionschutz

Braunschweig, 6 July 1999

By order

(Signature)
 Dr.-Ing. U. Jahnsmeyer
 Regierungsdirektor

(seal)

PTB1.doc



SAMSON AG · MESS- UND REGELTECHNIK
Weismüllerstraße 3 · 60314 Frankfurt am Main, Germany
Phone: +49 69 4009-0 · Fax: +49 69 4009-1507
samson@samson.de · www.samson.de

EB 8313-1 EN

2016-07-08 · English