

Series 3730 Type 3730-5 Electropneumatic Positioner



Communication: FOUNDATION™ fieldbus



Translation of original instructions

Configuration Manual

KH 8384-5 EN

Firmware version K 3.0x
Edition December 2017



Note on this manual

This manual assists you in mounting and operating the device safely. The manual is binding for handling SAMSON devices.

- For the safe and proper use of this manual, read it carefully and keep it for later reference.
- If you have any questions about this manual, contact SAMSON's After-sales Service Department (aftersaleservice@samson.de).



The manual for the devices is included in the scope of delivery. The latest documentation is available on our website (www.samson.de) > Product documentation. You can enter the document number or type number in the [Find:] field to look for a document.

! NOTICE

Installation, start-up and on-site operation of the positioner are described in the Mounting and Operating Instructions ► EB 8384-5.

Definition of signal words

! DANGER

Hazardous situations which, if not avoided, will result in death or serious injury

! WARNING

Hazardous situations which, if not avoided, could result in death or serious injury

! NOTICE

Property damage message or malfunction

i Note

Additional information

💡 Tip

Recommended action

1	Introduction	8
2	Design and principle of operation	9
2.1	Application type	10
2.2	Additional equipment	11
2.3	Configuration using TROVIS-VIEW	12
2.4	Communication	12
3	FOUNDATION™ fieldbus block model.....	12
4	Initialization and zero calibration of the positioner	13
5	Resetting the positioner.....	14
6	Status classification and condensed state.....	15
7	Block model	15
7.1	Resource Block (RES)	15
7.2	Transducer Blocks.....	16
7.3	Advanced Positioner Transducer Block (AO TRD)	17
7.4	Function blocks	18
7.4.1	Analog Output Function Block (AO FB)	18
7.4.2	Proportional Integral Derivative Function Block (PID).....	22
7.4.3	Discrete Input Function Block (DI1 FB + DI2 FB).....	24
8	Other parameters.....	26
8.1	Link Objects.....	26
8.2	LAS Functionality	26
9	Parameter lists	27
9.1	Resource Block (RES)	28
9.2	Advanced Positioner Transducer Block (AO TRD)	43
9.3	Analog Output Function Block (AO FB)	83
9.4	Analog Input Function Block (AI FB).....	91
9.5	Proportional Integral Derivative Function Block (PID).....	99
9.6	Discrete Output Function Block (DO FB)	115
9.7	Discrete Input Function Block (DI1 FB + DI2 FB).....	121

Firmware revisions (Communication K)

K 1.21

- **"Device not initialized" diagnostic alarm:** the diagnostic alarm "Device not initialized" is generated when the positioner is not initialized and the condensed state is set to "Maintenance alarm".
- **Leakage sensor at binary input 2:** The connection of a leakage sensor at binary input 2 (by selecting LEAKAGE_SENSOR in CONFIG_BINARY_INPUT2 parameter of the AO Transducer Block) causes:
 - Information specified in XD_ERROR_EXT parameter in the AO Transducer Block and the generation of a diagnostic alarm which is logged
 - The state of the binary input is reported in BINARY_INPUT2 parameter in the AO Transducer Block

The connection of a leakage sensor at binary input 2 (by selecting LEAKAGE_SENSOR in CONFIG_BINARY_INPUT2 parameter of the AO Transducer Block) causes:

- Information specified in XD_ERROR_EXT parameter in the AO Transducer Block and the generation of a diagnostic alarm which is logged
- The state of the binary input is reported in BINARY_INPUT2 parameter in the AO Transducer Block
- **Display of the operating range FINAL_VALUE_RANGE:** the correction of the operating range FINAL_VALUE_RANGE over on-site operation of the positioner (Code 8/9) is also transferred over fieldbus in firmware version K 1.21 and higher.
- **De-energized internal solenoid valve:** a masking allows to set whether a de-energized internal solenoid valve generates an AO block error, resulting in a block alarm.
- **SOLENOID_SELECT parameter:** the SOLENOID_SELECT parameter in firmware K 1.21 and higher allows to set whether a "Maintenance now" block error of the AO Transducer Block results in an output error in the AO Function Block.
- **TOT_VALVE_TRAV_LIM parameter:** new range: 1000 to 990 000 000

K 1.22

- **Operating range FINAL_VALUE_RANGE:** the operating range FINAL_VALUE_RANGE of the AO Transducer Block is compared on entering it with TRANSM_PIN_POS. If the TRANSM_PIN_POS parameter is changed, the positioner checks whether the setting and unit match the current operating range FINAL_VALUE_RANGE. If this is not the case, the FINAL_VALUE_RANGE parameter is set to 0 to 100 %.
- **VALVE_TYPE parameter:** the parameter of the AO Transducer Block is set depending on the selected PIN_POS. The last setting is kept when VALVE_TYPE is set to OFF.
- **FINAL_VALUE parameter:** the output value is scaled with FINAL_VALUE_RANGE in firmware K 1.22 and higher and not as previously with XD_SCALE.
- **Display of O/S mode in AO Transducer Block:** if the AO Transducer Block is set to O/S mode, this is indicated in the positioner display by MAN/AUTO.

K 1.23

Internal revisions

Firmware revisions (Communication K)
<p>K 1.24</p> <ul style="list-style-type: none"> • BUS_ADDRESS parameter: the bus address has the default setting of 248. • Device type: in the delivered state, the device is configured as a basic device.
<p>K 1.25 Internal revisions</p>
<p>K 2.01</p> <ul style="list-style-type: none"> • Additional function blocks: 2x DO (Discrete Output), 1x IS (Input Selector), 1x MAI (Multiple Analog Input), 1x MAO (Multiple Analog Output). • New functions: the following new functions are implemented in the DO Function Block (Discrete Output): <ul style="list-style-type: none"> • Discrete analysis of on/off valves • Start partial stroke test (PST) • Start and reset the data logger • Resetting the diagnosis • Stop diagnosis • Move to fail-safe position • Lock on-site operation • Action on fault detection: If the AO Transducer Block is in O/S mode and the condensed state changes to "Maintenance alarm", the following actions can be started: <ul style="list-style-type: none"> • Hold last value • Move valve to fail-safe position • Move to a predefined fault state value
<p>K 2.02 Partial stroke test (PST): configuration of the partial stroke test (PST) over the FF parameters is no longer possible. Configuration over the TROVIS-VIEW software is still possible.</p>
<p>K 2.03 Partial stroke test (PST): configuration of the partial stroke test (PST) over the FF parameters is no longer possible. Configuration over the TROVIS-VIEW software is still possible. The partial stroke test can be started over the binary input BI2.</p>
<p>K 2.04 Internal revisions</p>
<p>K 2.05 Internal revisions</p>
<p>K 2.06 Process control system: new firmware compatible with Honeywell Experion® control system. Communication: improved communication of valve positions smaller than -0.9 %.</p>
<p>K 2.07 Testing device functioning: monitoring of internal device communication has been added to the cyclic testing of the device functions.</p>

Firmware revisions (Communication K)

K 3.01

- Certified according to ITK 6.2.0
- Diagnostics specification according to FF-912
- Function block added: AI (Analog Input)
- Function blocks removed: MAI (Multiple Analog Input), MAO (Multiple Analog Output), IS (Input Selector)

1 Introduction

This document is based upon:

- Fieldbus FOUNDATION™ Specification "Function Block Application Process Part 1 – 3" Revision 1.7 (FF-890 to FF-892)
- Fieldbus FOUNDATION™ Specification "Positioner Transducer Block" Revision 3.0 (FF-906)

Type 3730-5 Positioner

The microprocessor-controlled positioner compares the set point cyclically transmitted over the FOUNDATION™ fieldbus network to the travel or opening angle of the control valve and issues a corresponding output signal pressure.

Special features:

- Link Master Capability
- Simple attachment to all common linear actuators with interface for SAMSON direct attachment, NAMUR rib or valves with rod-type yokes according to IEC 60534-6-1 or to rotary actuators according to VDI/VDE 3845
- Any desired mounting position of the positioner
- One-knob, menu-driven operation
- Automatic start-up
- LCD easy to read in any mounted position due to selectable reading direction
- Integrated EXPERTplus diagnostics suitable for throttling and on/off valves and with additional partial stroke test for valves in safety-instrumented systems
- Classified status messages acc. to NAMUR Recommendation NE 107
- Online changing of control parameters
- Automatic zero monitoring
- Calibrated travel sensor without gears susceptible to wear
- Permanent storage of parameters (protected against power failure)
- Adjustable output pressure limitation
- Activatable tight-closing function
- Binary input for DC voltage signals
- Certified according to IEC 61508/SIL

2 Design and principle of operation

The positioner is mounted on pneumatic control valves and is used to assign the valve position (controlled variable x) to the control signal (set point w). The positioner compares the control signal of a control system to the travel or rotational angle of the control valve and issues a signal pressure (output variable y) for the pneumatic actuator.

The positioner mainly consists of an electric travel sensor system, an analog i/p converter with a downstream air capacity booster and the electronics with the microcontroller.

When a set point deviation occurs, the actuator is either vented or filled with air. If necessary, the signal pressure change can be slowed down by a volume restriction. The signal pressure supplied to the actuator can be limited by software or on site to 1.4, 2.4 or 3.7 bar.

The fixed flow regulator ensures a constant air flow to the atmosphere, which is used to flush the inside of the positioner housing and to optimize the air capacity booster. The i/p converter is supplied with a constant upstream pressure by the pressure regulator to compensate for any fluctuations in the supply pressure.

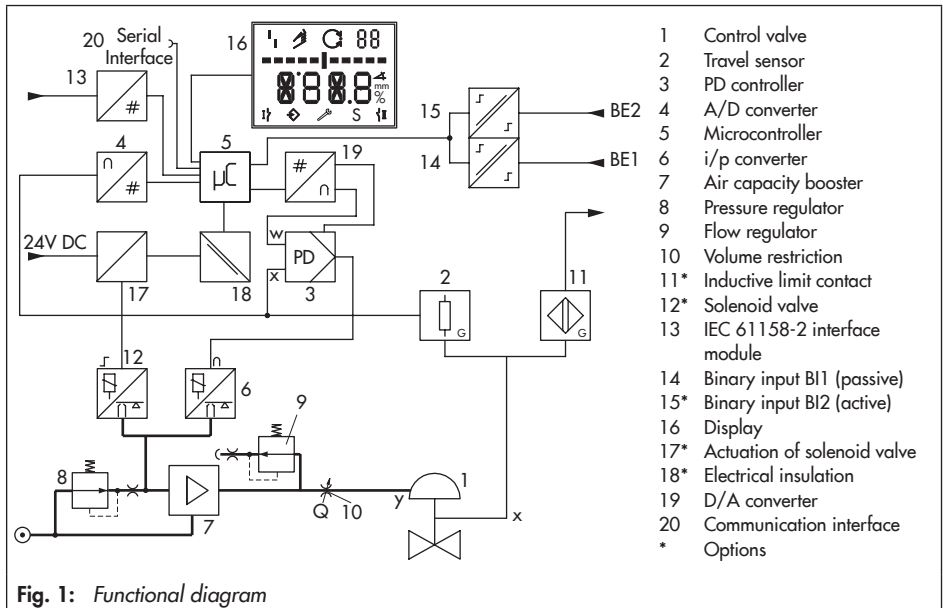

The positioner communicates and is powered using IEC 61158-2 transmission technology conforming to FOUNDATION™ fieldbus specification.

As a standard feature, the positioner comes with a binary input used to signalize process information over the FOUNDATION™ fieldbus network.

The extended EXPERTplus diagnostics are integrated into the positioner. They provide information on the positioner and generate diagnostic and status messages, which allow faults to be pinpointed quickly.

2.1 Application type

The application types '**Control valve**' and '**On/off valve**' are available. The manual mode ↗ (MAN) and the automatic mode (AUTO) can be selected with both application types.

Depending on the application type selected, the positioner responds differently in automatic mode (AUTO) ⚙.

Control over FOUNDATION™ fieldbus is performed over the AO Function Block (control valve) and over the DO1 Function Block (on/off valve). The application type can be entered in the Resource Block over the SELECT_DO_1 parameter or at the positioner using Code 49 - h0.

	Control valve	Open/close (on/off) valve
AUTO mode ⚙	The positioner uses the set point to position the valve. The valve position (current position) appears in % on the display.	Discrete analysis of the set point The valve position (current position) in % and O/C (Open/Close) appear in alternating sequence on the display.
MAN mode ↗	The positioner follows the set point given over local operation.	

i Note

- Depending on the application type, certain diagnostic functions cannot be performed or analyzed (▶ EB 8389 on EXPERTplus valve diagnostics).
- In manual mode, an on/off valve can be moved past 100 % of the nominal range (with the closed position for AIR TO OPEN) or below 0 % of the nominal range (with the closed position for AIR TO CLOSE).

2.2 Additional equipment

Solenoid valve

If the operating voltage for the solenoid valve (12) fails, the supply pressure for the i/p converter is vented to the atmosphere. The positioner can no longer operate and the control valve moves to the fail-safe position determined by the actuator, regardless of the set point.

! NOTICE

*The manual set point is also reset to 0 % after the solenoid valve is activated!
A different manual set point must be entered again (Code 1).*

Inductive limit contact

In this version, the rotary shaft of the positioner carries an adjustable tag which actuates the built-in proximity switch.

External position sensor

In this version, only the sensor is mounted to the control valve. The positioner is located separately from the valve. The connection of x and y signals to the valve is established by cable and piping for air (only without inductive limit contact).

Leakage sensor

By upgrading the positioner with a leakage sensor, it is possible to detect seat leakage when the valve is in the closed position.

Binary inputs

Binary input BI1 (14)

As a standard feature, the positioner comes with a binary input used to signalize process information over the FOUNDATION™ fieldbus network.

Binary input BI2 (15)

This binary input BI2 is optional. It is an active input which is powered by the positioner to connect a floating contact. The switching state of the floating contact can be indicated over the FOUNDATION™ fieldbus network.

i Note

The binary inputs are configured in the DI Function Blocks.

2.3 Configuration using TROVIS-VIEW

The positioner can be configured with SAMSON's TROVIS-VIEW Software.

The positioner has for this purpose a serial interface to allow the RS-232 or USB port of a computer to be connected to it using an adapter cable.

The TROVIS-VIEW software enables the user to easily configure the positioner as well as view process parameters online.

2.4 Communication

The positioner is controlled completely by digital signal transmission according to FOUNDATION™ fieldbus specification.

Data are transmitted over the bus using digital, bit-synchronous Manchester coding at a Baud rate of 31.25 kbit/s over twisted-pair wires according to IEC 61158-2.

i Note

If complex functions are started in the positioner, which require a long calculation time or lead to a large quantity of data being saved in the volatile memory of the positioner, the alert 'busy' is issued over the DD. This alert is not an error message and can be simply confirmed.

3 FOUNDATION™ fieldbus block model

All the functions and data of the positioner are assigned to various block types in FOUNDATION™ fieldbus. Each block type covers a different range of tasks. In the SAMSON Type 3730-5 Positioner, the following block types are implemented:

Resource Block (RES)

The Resource Block (RES) describes characteristics of the fieldbus device, such as the device name, manufacturer number and serial number. There is only one Resource Block in a device.

Function Blocks (FB)

Function Blocks are responsible for the way a FOUNDATION™ fieldbus device works. A FOUNDATION™ fieldbus application can be configured by linking the input and output parameters of Function Blocks.

The Type 3730-5 Positioner includes the following Function Blocks:

- 1x Analog Output Function Blocks (AO FB); execution time: 30 ms
- 1x Analog Input Function Blocks (AI FB); execution time: 30 ms
- 2x Discrete Output Function Blocks (DO FB); execution time: 30 ms
- 2x Discrete Input Function Blocks (DI FB); execution time: 20 ms
- 1x Proportional Integral Derivative Function Block (PID); execution time: 40 ms

Transducer Blocks (TRD)

Each AI or AO Function Block has a Transducer Block which contains all data and device-specific parameters to link the device to the process value (sensor or final control element).

The following Transducer Blocks (corresponding to the Function Blocks) are implemented:

- 1x Advanced Positioner Transducer Block (AO TRD)
- 1x Analog Input Transducer Block (AI TRD)
- 2x Discrete Output Transducer Blocks (DO TRD)
- 2x Discrete Input Transducer Blocks (DI TRD)

4 Initialization and zero calibration of the positioner

Both an initialization and a zero calibration can be started over the XD_COMMAND parameter of the AO Transducer Block. The relevant parameters for a MAX/NOM initialization and the diagnostic functions of EXPERTplus are listed below (► EB 8389).

- APPLICATION_TYPE_OC_CONTROL (application type)
- INIT_METHOD (initialization method)

- TRANS_PIN_POS (follower pin position)
- RATED_TRAVEL (required rated travel for NOM initialization)
- PRESSURE_LIMIT (pressure limit setting)
- SELECT_EMERGENCY_MODE (E (setting when the travel sensor is defective))
- DEVICE_CHARACTERISTIC (C (settings for actuator and other accessories)
 - MODEL (actuator with or without spring-return mechanism)
 - BOOSTER (pneumatic volume booster)
 - STUFFING_BOX (packing to seal the plug stem to the atmosphere)
 - XD_COMMAND ("Start Initialization")
 - XD_COMMAND_STATE (initialization status)

i Note

Read the corresponding section on starting up the positioner in the *Mounting and Operating Instructions* ► *EB 8384-5*.

5 Resetting the positioner

The start-up and diagnostic data (in Code 36 Std) can be reset over the XD_COMMAND (41) parameter of the AO Transducer Block.

The device data are reset and the function blocks connected to the values given in the FOUNDATION™ fieldbus specification using the DEFAULTS value in the RESTART (16) parameter of the Resource Block (RES).

A warm start of the positioner is performed using the PROCESSOR value in the RESTART (16) parameter of the Resource Block (RES).

The entire diagnostic data as well as the individual messages and histograms are reset over the RESET_STATUS_MESSAGE_DIAG (147) parameter of the AO Transducer Block.

6 Status classification and condensed state

All status messages are classified in the positioner to report an error that has occurred. The status classification can be changed over the DIAG_CLS parameter.

To provide a better overview, the classified messages are summarized in a condensed state (CONDENSED_STATE (81) in the Resource Block). Besides the CONDENSED_STATE parameter, the condensed state can be issued to the discrete output OUT_D of the DI Function Blocks (DI1 + DI2).

Possible condensed states include:

0	OK	
1	Maintenance required	The positioner still performs its control task (with restrictions). A maintenance demand or above average wear has been determined. The wear tolerance will soon be exhausted or is reducing at a faster rate than expected. Maintenance is necessary in the medium term.
2	Maintenance demanded	The positioner still performs its control task (with restrictions). A maintenance demand or above average wear has been determined. The wear tolerance will soon be exhausted or is reducing at a faster rate than expected. Maintenance is necessary in the short term.
3	Maintenance alarm	The positioner cannot perform its control task due to a functional fault in the positioner itself or in one of its peripherals or an initialization has not yet been successfully completed.
7	Function check	Test or calibration procedures are performed in the positioner. The positioner is temporarily unable to perform its control task as long as the procedure is taking place.

7 Block model

Several parameters can only be changed in certain modes (see Read/write capability in the parameter description). In this case, not the actual mode is decisive, but the target mode.

7.1 Resource Block (RES)

The Resource Block contains all the data that identify the device. It is similar to an electronic device tag. Resource Block parameters include device type, device name, manufacturer ID, serial number as well as parameters that affect the behavior of all other blocks of the device.

See page 27 for parameter list.

i Note

All time specifications in the Resource Block are specified in the unit of 1/32 ms according to the FOUNDATION™ fieldbus Specification Version 1.7.

In the Device Description Library supplied by Fieldbus FOUNDATION™ upon which the device description of Type 3730-5 is also based, these parameters are incorrectly specified as the unit of ms. The specified values supplied by the device are, however, always to be interpreted as the unit of 1/32 ms.

7.2 Transducer Blocks

Transducer Blocks link the function blocks to the input and output variables of a field device. For example, the DI Function Blocks are linked to the physical binary inputs, an internal solenoid valve, the current valve position or the condensed state of the positioner. This link to the various Transducer Blocks is made over the CHANNEL parameter of the individual function blocks. The table below shows how CHANNEL is assigned to the function block:

CHANNEL	Function block
1	AO
2	AI
3	DI1
4	DI2
5	DO1
6	DO2

The Transducer Blocks DI TRD and DO TRD are implemented according to the FOUNDATION™ fieldbus specification and do not contain any manufacturer-specific parameters.

7.3 Advanced Positioner Transducer Block (AO TRD)

The Advanced Positioner Transducer Block (AO TRD) contains an output value from an upstream Analog Output Function Block. This value is used to position a control valve. The block contains parameters to adapt the positioner to the actuator and valve as well as for valve start-up and diagnostics.

Action on fault detection

The action on fault detection for the "Maintenance alarm" state in the condensed state can be configured in the XD_FSTATE_OPT parameter as follows:

- Hold last value
- Move to fail-safe position
- Move to fault state value XD_FSTATE_VAL

The action on fault detection to transfer to the O/S mode can be configured in the XD_OOS_OPT parameter as follows:

- Hold last value
- Move to fail-safe position
- Move to fault state value XD_FSTATE_VAL

The AO Transducer Block (AO TRD) can still set an output error in the AO Function Block. For this purpose, the following events to activate an output error can be configured in the ALARM_OPTION parameter.

- No (never)
- Local Override (when the AO TRD is in the LOCAL OVERRIDE mode, i.e. the positioner is set locally in the SAFE mode or an internal solenoid valve is activated)
- MAN (when the AO TRD is in MAN mode)
- Block alarm (when the AO TRD has a MAINTENANCE NOW block error)
- AO TRD fault state (when the action on fault detection is active)
- AO O/S set fault state (when the AO Function Block in the O/S mode, the valve is moved to the FSTATE_VAL of the AO Function Block)

Parameter description (Fig. 5)

Control valve	
FINAL_VALUE	Set point of upstream AO Function Block (control valve)
FINAL_POS_VALUE	Valve position after rescaling
WORKING_SP	Set point after scaling, characterization, end position function (corresponds to the controlled variable of the control algorithm)
WORKING_POS	Actual valve position
READBACK_SELECT	Select parameter which is issued to READBACK of the AO Function Block
On/off valve	
FINAL_VALUE_D	Discrete set point of upstream DO Function Block
FINAL_POS_VALUE_D	Discrete valve position after taking the direction of action into account
WORKING_SP_D	Set point after taking the direction of action into account (corresponds to the set point of the control algorithm)
WORKING_POS_D	Actual discrete valve position

See page 43 for parameter list.

7.4 Function blocks

7.4.1 Analog Output Function Block (AO FB)

The AO Function Block processes an analog signal from an upstream block (e.g. PID Function Block) to an output value that can be used for the downstream Transducer Block (e.g. valve positioner). It contains scaling functions and ramp functions as well as other functions. The generated OUT value is forwarded over CHANNEL to the downstream Transducer Block.

The AO Function Block contains its set point SP depending on the mode (MODE_BLK)

- Manually entered SP (AUTO)
- Directly from an upstream function block (CAS_IN)
- Directly from a fieldbus host system (RCAS_IN)

An internal working process value PV is generated from SP, while taking into account:

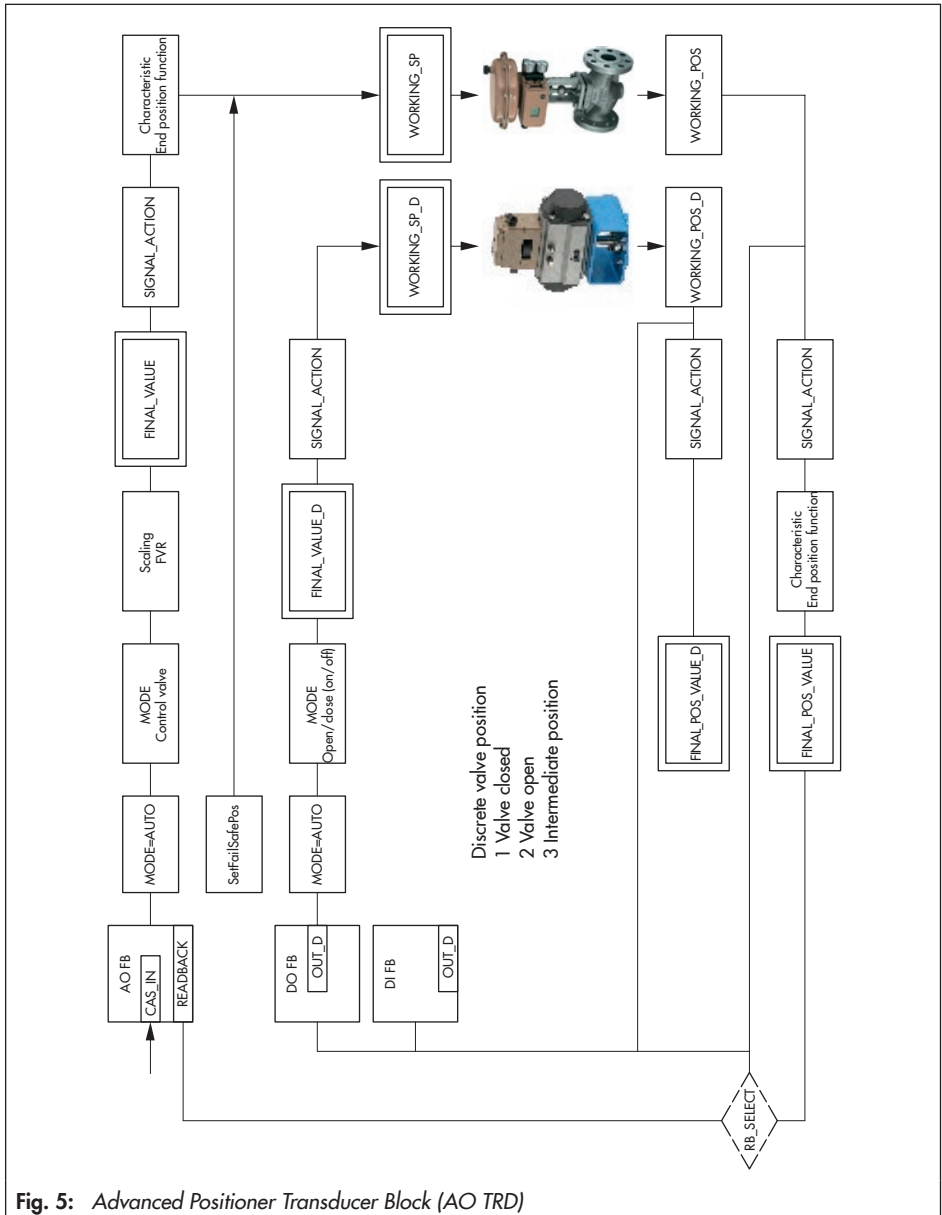

Fig. 5: Advanced Positioner Transducer Block (AO TRD)

- SP_HI_LIM (upper set point limit)
- SP_LO_LIM (lower set point limit)
- SP_RATE_DN (set point downward rate limit in AUTO mode)
- SP_RATE_UP (set point upward rate limit in AUTO mode)
- PV_SCALE (range of the process variable (PV) (start, end, unit and decimal point))

The OUT value is generated, while taking into account:

- XD_SCALE (range of the OUT value (start, end, unit and decimal point))
- IO_OPTS (determines the input/output action of the AO TRD, e.g. action on fault detection)

Action on fault detection

Action on fault detection taken during a communication fault (BAD status)

- The last valid value is used by default.
- By selecting FAULT STATE TO VALUE in the IO_OPTS parameter, the valve moves to the fault state value FSTATE_VAL configured in the AO Function Block.
- FSTATE_TIME defines the length of time that the AO Function Block will wait to activate the fault state.

Action on fault detection in OUT OF SERVICE (O/S) mode

- After the AO Function Block has moved to O/S mode, the last valid output value is kept by default.
- By selecting "AO O/S set fault state" in the ALARM_OPTION parameter of AO TRD, the valve moves to the fault state value FSTATE_VAL configured in the AO Function Block.
- FSTATE_TIME defines the length of time that the AO Function Block will wait to activate the fault state.

See page 83 for parameter list.

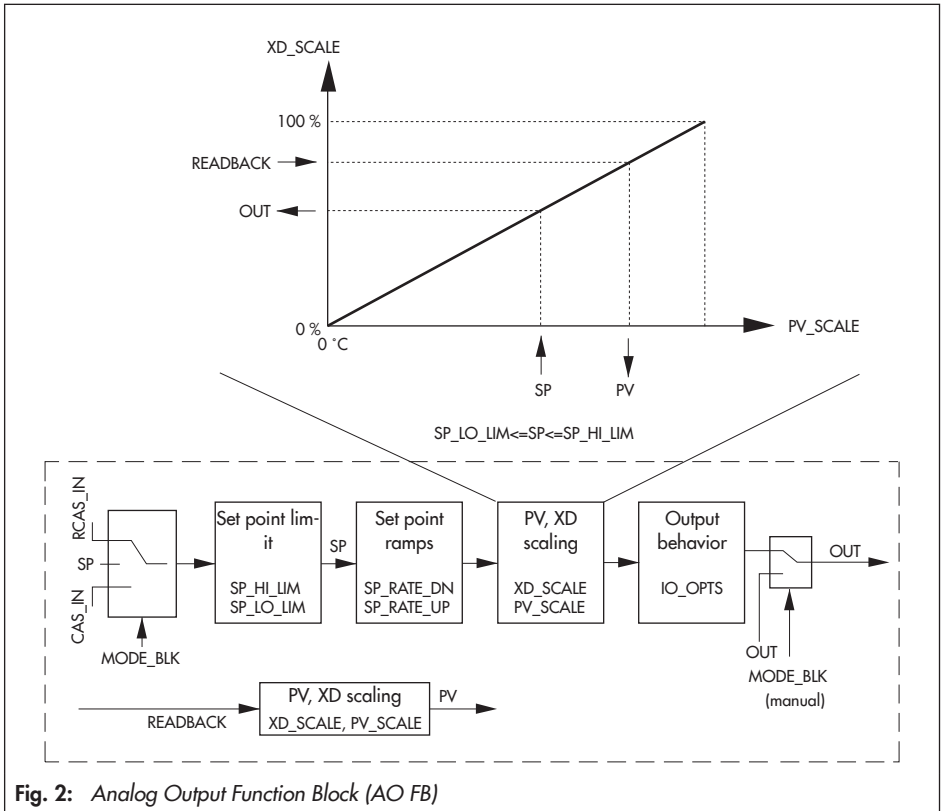

Fig. 2: Analog Output Function Block (AO FB)

7.4.2 Proportional Integral Derivative Function Block (PID)

A PID Function Block contains the input channel processing, the proportional-integral-derivative (PID) control loop and the analog output channel processing.

The configuration of the PID Function Block (PID controller) depends on the automation task. Simple control loops, control loops with feedforward control, cascade control and cascade controls with limitation in combination with another controller function block can be implemented.

The following options are available for data processing within the PID Function Block (PID controller): signal scaling and limiting, mode control, feedforward control, override tracking, alarm limit detection and signal status propagation.

The PID Function Block (PID controller) can be used for various automation strategies. The block has a flexible control algorithm that can be configured to match the application.

The PID Function Block receives its set point depending on the mode (MODE_BLK) from the input variables CAS_IN, RCAS_IN or SP. An internal working set point is generated based on PV_SCALE, SP_HI_LIM, SP_LO_LIM, SP_RATE_UP and SP_RATE_DN.

The block receives the process value over the IN input variable which is used to generate the process variable PV, taking into account the PV_SCALE and the filter of the first order PV_FTME.

These values are fed to the internal PID algorithm. This algorithm consists of a proportional, an integral and a derivative component. The output value is calculated from the set point SP and the process variable PV resulting from the set point deviation.

The single PID components are included in the calculation of the output value as follows:

- Proportional component:
The proportional component reacts immediately and directly when the set point SP or the process variable PV changes. The output variable is changed by the proportional factor GAIN. This change corresponds to the set point deviation multiplied by the gain factor. If a controller works only with a proportional component, the control loop has a steady-state error signal.
- Integral component:
The set point deviation resulting from the calculation of the output variable using the proportional component is integrated over the integral component of the controller until it is negligible. The integral function corrects the output variable depending on the size and duration of the set point deviation. If the value for the integration time RESET is set to zero, the controller works as a P or PD controller. The influence of the integral component on the control loop increases when the value of the integration time RESET is reduced.

– Derivative component:

In controlled systems with long delay times, e.g. in temperature control loops, it is better to use the derivative component RATE of the controller. Using the derivative component RATE, the output variable is calculated depending on the rate of change of the set point deviation.

An OUT value is generated from the calculated output value based on the OUT_SCALE, OUT_HI_LIM and OUT_LO_LIM parameters. It can be forwarded to a downstream function block.

The status of the OUT value can be influenced by the STATUS_OPTS parameter depending on the status of the input variables of the PID Function Block. As a result, the fault state of a following output block can be activated, for example.

The BYPASS parameter allows the internal set point to pass directly through to the output value. The FF_VAL input value allows feedforward control, while TRK_IN_D and TRK_VAL allow the direct tracking of the out value.

See page 99 for parameter list.

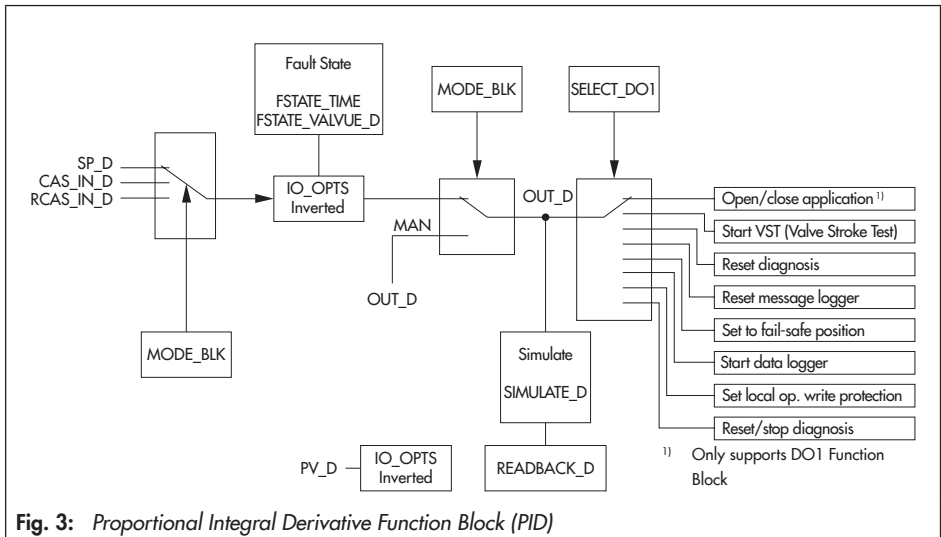

Fig. 3: Proportional Integral Derivative Function Block (PID)

7.4.3 Discrete Input Function Block (DI1 FB + DI2 FB)

The DI Function Block processes single discrete signals and provides them to other function blocks over the OUT_D parameter. The positioner has two DI Function Blocks which provide the options listed in following. The application type is set over the SELECT_DI_1...2 parameters of the Resource Block.

- 5 – 30 VDC (DI1)

As a standard feature, the positioner comes with a contact input to analyze binary voltage signals (terminals 87 and 88). The DI1 Function Block analyzes the state of the contact and issues it over OUT_D.

- Floating contact (DI2)

The positioner can be fitted with an optional binary input to analyze a floating contact (terminals 85 and 86). The DI2 Function Block analyzes the state of the contact and issues it over OUT_D.

When a pressure sensor (leakage sensor) is connected, its switching state can be issued as a diagnostic alarm in the XD_ERROR_EXT parameter of the AO Transducer Block and logged. In this case, the 'Actively Open – Ext. Leak. Sens.' or 'Actively Closed – Ext. Leak. Sens.' option must be activated in CONFIG_BINARY_INPUT2. Additionally, the switching state of the binary input is issued in the BINARY_INPUT2 parameter of the AO Transducer Block.

- Int. solenoid valve (DI1, DI2)

In this setting, the current switching state of the optional internal solenoid valve is analyzed and issued over OUT_D. '0' indicates a de-energized solenoid valve ($U < 15 \text{ V DC}$) and '1' an energized solenoid valve ($U > 19 \text{ V DC}$).

- Discr. final valve position (DI1, DI2)

In this setting, the current discrete valve position is issued over OUT_D. The values are assigned as follows:

- 0 Device not initialized
- 1 Valve closed
- 2 Valve open
- 3 Valve in intermediate position

– Condensed State (DI1, DI2)

In this setting, the current condensed state according to NAMUR Recommendation NE 107 is issued over OUT_D. The status messages are assigned to the discrete value as follows:

- 0 No message
- 1 Maintenance required
- 2 Maintenance demanded
- 3 Maintenance alarm
- 7 Function check

See page 121 for parameter list.

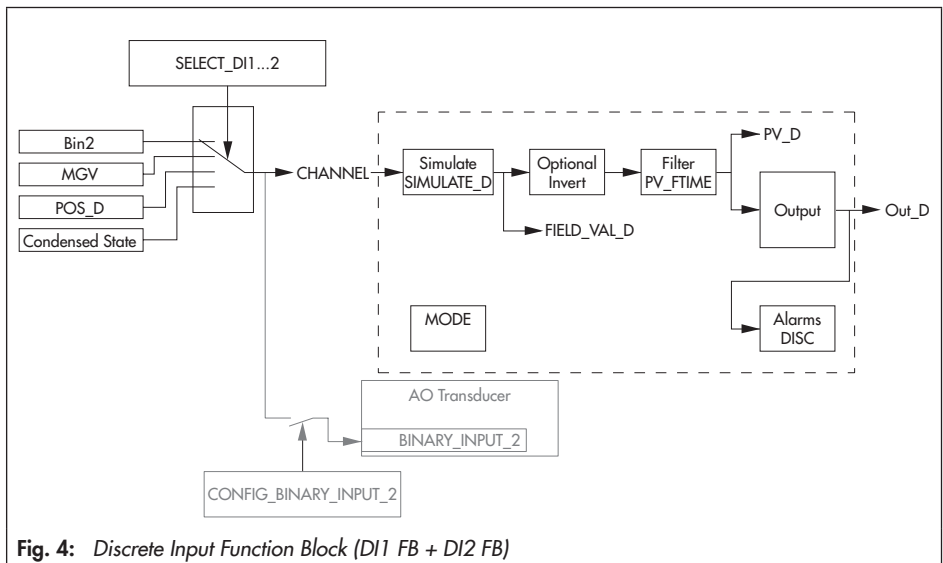

8 Other parameters

The Stale Counter serves to judge the "quality" of a process variable received over a configured cyclic connection (publisher/subscriber connection).

These connections are used to transfer the process variable linked amongst the various function blocks. For this purpose, the upstream block (publisher) sends the process variable over the bus at scheduled times. The downstream block(s) (subscriber) responds at the scheduled times. The blocks that are to receive data monitor whether a valid value exists at the scheduled time. A value is valid if it exists with the status "Good" at the scheduled time.

The Stale Counter defines how many "Bad" (stale) values can be accepted in sequence before the Fault State of the block is activated.

This monitoring function is deactivated by setting the Stale Counter to zero.

8.1 Link Objects

Link Objects are used to link the inputs and outputs of the function blocks (configurable cyclic connections).

A maximum of 22 Link Objects can be configured for each positioner.

8.2 LAS Functionality

The number of links and schedules that can be used is matched to the requirements of standard process control systems available on the market.

The positioner functioning as an LAS can support the following:

- 2 schedules
- 2 subschedules
- 5 sequences per subschedule
- 48 elements per sequence

In the delivered state, the device is configured as a basic device.

9 Parameter lists

Legend

The parameter index is listed in brackets following the parameter name in the following tables.

Storage class	S	Static parameter
	D	Dynamic parameter
	N	Non-volatile parameter
Read/write capability	r	Read capability
	w	Write capability
Access	O	O/S (out of service) mode
	M	MAN mode
	A	AUTO mode
	CAS	Cascade mode
	RCAS	External cascade mode
	ALL	O/M/A/CAS/RCAS
Other operating modes:	LO	Local override mode
	ROUT	External output mode

i Note

Values/settings in square brackets [] are default settings. Resource Block (RES)

RES:	<p>ACK_OPTIONS (38) Storage class S; read/write capability r/w; supported modes O/A</p> <p>Automatic alarm acknowledgement</p> <ul style="list-style-type: none"> • Resource Block • [UNDEFINED] · No selection • DISC ALM · Write protection was changed • BLOCK ALM · Block alarm <p>Note: The alarm is broadcast to the fieldbus host system, but not acknowledged by it.</p>
RES:	<p>ALARM_SUM (37) Storage class S; read/write capability r/w; supported modes O/A</p> <p>Current status of process alarms in the Resource Block</p> <ul style="list-style-type: none"> • DISC ALM · Write protection was changed • BLOCK ALM · Block alarm <p>Note: The process alarms can also be deactivated in this parameter group.</p>
RES:	<p>ALERT_KEY (4) Storage class S; read/write capability r/w; supported modes O/A</p> <p>ID number of the plant section</p> <ul style="list-style-type: none"> • 1 to 255, [0] <p>Used by the fieldbus host system to sort alarms and events.</p> <p>Note: '0' is not permissible and will be rejected when transferring data to the device (error alarm).</p>
RES:	<p>ALL_ACTIVE_STATUS_MESSAGES (84) Storage class S; read/write capability r/w</p> <p>Active status or error messages of the diagnostics</p>
RES:	<p>BLOCK_ALM (36) Storage class D; read capability r</p> <p>Current block state with details on all configuration, hardware or system problems in the block including date and time stamp.</p>

RES:	<p>BLOCK_ERR (6)</p> <p>Storage class D; read capability r</p> <p>Active block errors → Code 48 S2</p> <ul style="list-style-type: none"> • SIMULATE ACTIVE · Simulation jumper active, simulation possible • OUT OF SERVICE · Block mode is out of service • LOST STATIC DATA · Data loss in EEPROM • DEVICE NEEDS MAINTENANCE SOON · Maintenance required soon. This message triggers a block alarm (BLOCK_ALM) in the Resource Block. • DEVICE NEEDS MAINTENANCE NOW · Maintenance required now. This message triggers a block alarm (BLOCK_ALM) in the Resource Block. <p>Note: The assignment of error or diagnostic alarms to the desired function block is made using the ERROR_OPTION parameters in the Transducer Block.</p>
RES:	<p>BUS_ADDRESS (78)</p> <p>Storage class D; read capability r</p> <p>Bus address → Code 46</p> <ul style="list-style-type: none"> • 0 to 255, [248]
RES:	<p>CLR_FSTATE (30)</p> <p>Storage class D; read/write capability r/w; supported modes O/A</p> <p>Deactivation of the fault state of the AO Function Block</p>
RES:	<p>CONDENSED_STATE (81)</p> <p>Storage class D; read capability r</p> <p>Displays the current condensed state according to NAMUR Recommendation NE 107</p>
RES:	<p>CONFIRM_TIME (33)</p> <p>Storage class S; read/write capability r/w; supported modes O/A</p> <p>Confirmation time for event report</p> <p>If the device does not receive a confirmation within this period of time, the event report is sent again.</p> <ul style="list-style-type: none"> • [640000 ms]
RES:	<p>CYCLE_SEL (20)</p> <p>Storage class S; read/write capability r/w; supported modes O/A</p> <p>Block execution method determined by the fieldbus host system</p> <ul style="list-style-type: none"> • [Scheduled] • Block Execution · Block execution completed • Manuf Specific · Not analyzed <p>Note: The execution method is selected directly in the fieldbus host system.</p>

RES:	CYCLE_TYPE (19) Storage class S; read capability r Block execution method supported by the device <ul style="list-style-type: none"> • Scheduled • Block Execution · Block execution completed
RES:	DD_RESOURCE (9) Storage class S; read capability r Source of the device description in the device Note: If no device description is available in the device, zero is displayed.
RES:	DD_REV (13) Storage class S; read capability r Revision number of the device description
RES:	DESCRIPTOR (69) Storage class S; read/write capability r/w; supported modes O/A Any desired text to describe the application. The text is saved in the field device. <ul style="list-style-type: none"> • Max. 32 characters, [no text]
RES:	DEVICE_CERTIFICATION (68) Storage class N; read capability r Certification · Specifies whether explosion protection certificates are available for the Type 3730-5.
RES:	DEVICE_MESSAGE (70) Storage class N; read/write capability r/w; supported modes O/A Any desired text. The text is saved in the field device. <ul style="list-style-type: none"> • Max. 32 characters, [no text]
RES:	DEVICE_PRODUCT_NUM (71) Storage class N; read capability r Article code of the positioner as assigned by the manufacturer
RES:	DEVICE_SER_NUM (67) Storage class N; read capability r Serial number of the positioner
RES:	DEV_REV (12) Storage class S; read capability r Revision number of the positioner

RES:	DEV_TYPE (11) Storage class S; read capability r Type number of the positioner (decimal number) • In this case: Type 3730-5
RES:	DIAG_CLS (82) Storage class S; read/write capability r/w Classification of diagnostic, status or error messages
RES:	FAULT_STATE (28) Storage class N; read capability r Status of the fault state of the Analog Output Function Block
RES:	FD_CHECK_ACTIVE (46) Storage class D; read/write capability r Active error messages with the 'Function check' status
RES:	FD_CHECK_ALM (58) Storage class D; read/write capability r Active, not suppressed diagnostic messages with the 'Function check' status
RES:	FD_CHECK_MAP (50) Storage class S; read/write capability r/w Classification of diagnostic messages with the 'Function check' status
RES:	FD_CHECK_MASK (54) Storage class S; read/write capability r/w Activation/deactivation of diagnostic messages with the 'Function check' status
RES:	FD_CHECK_PRI (62) Storage class S; read/write capability r/w Determines the priority of diagnostic messages with the 'Function check' status
RES:	FD_FAIL_ACTIVE (43) Storage class D; read/write capability r Active error messages with the 'Maintenance alarm' status
RES:	FD_FAIL_ALM (55) Storage class D; read/write capability r Active, not suppressed diagnostic messages with the 'Maintenance alarm' status

RES:	FD_FAIL_MAP (47) Storage class S; read/write capability r/w Classification of diagnostic messages with the 'Maintenance alarm' status
RES:	FD_FAIL_MASK (51) Storage class S; read/write capability r/w Activation/deactivation of diagnostic messages with the 'Maintenance alarm' status
RES:	FD_FAIL_PRI (59) Storage class S; read/write capability r/w Determines the priority of diagnostic messages with the 'Maintenance alarm' status
RES:	FD_MAINT_ACTIVE (45) Storage class D; read/write capability r Active error messages with the 'Maintenance demanded' status
RES:	FD_MAINT_ALM (57) Storage class D; read/write capability r Active, not suppressed diagnostic messages with the 'Maintenance demanded' status
RES:	FD_MAINT_MAP (49) Storage class S; read/write capability r/w Classification of diagnostic messages with the 'Maintenance demanded' status
RES:	FD_MAINT_MASK (53) Storage class S; read/write capability r/w Activation/deactivation of diagnostic messages with the 'Maintenance demanded' status
RES:	FD_MAINT_PRI (61) Storage class S; read/write capability r/w Determines the priority of diagnostic messages with the 'Maintenance demanded' status
RES:	FD_OFFSPEC_ACTIVE (44) Storage class D; read/write capability r Active error messages with the 'Out of specification' status
RES:	FD_OFFSPEC_ALM (56) Storage class D; read/write capability r Active, not suppressed diagnostic messages with the 'Out of specification' status

RES:	FD_OFFSPEC_MAP (48) Storage class S; read/write capability r/w Classification of diagnostic messages with the 'Out of specification' status
RES:	FD_OFFSPEC_MASK (52) Storage class S; read/write capability r/w Activation/deactivation of diagnostic messages with the 'Out of specification' status
RES:	FD_OFFSPEC_PRI (60) Storage class S; read/write capability r/w Determines the priority of diagnostic messages with the 'Out of specification' status
RES:	FD_RECOMMEN_ACT (64) Storage class D; read/write capability r Recommended action
RES:	FD_SIMULATE (63) Storage class S; read/write capability r/w Simulation of diagnostic messages
RES:	FD_VER (42) Storage class S; read/write capability r Field diagnostic specification version • [1]
RES:	FEATURES (17) Storage class S; read capability r Additional functions supported by the device, see FEATURES_SEL
RES:	FEATURES_SEL (18) Storage class S; read/write capability r/w; supported modes O/A Selects the additional functions supported by the device • REPORTS · Fieldbus host system needs to acknowledge receipt of the event report. • HARD W LOCK · Write lock switch hardware is assessed. • FAULTSTATE · Fault state can be triggered (see SET_FSTATE/CLR_FSTATE). • OUT READBACK · Current valve position issued in the PV parameter of the Analog Function Block (otherwise in SP parameter). Note: If the AO Function Block is not to move to the MAN mode when the forced venting function is activated or the solenoid valve is triggered, deactivate this option.

Parameter lists

RES:	FIRMWARE_REVISION (65) Storage class N; read capability r Firmware version for communication and control
RES:	FREE_SPACE (24) · This parameter is not supported.
RES:	FREE_TIME (25) · This parameter is not supported.
RES:	GRANT_DENY (14) Storage class D; read/write capability r/w; supported modes NA Grant or deny a fieldbus host system access to the field device Note: This parameter is not analyzed by Type 3730-5.
RES:	HARD_TYPES (15) Storage class S; read capability r Types of input and output signals (hardware) available for the device <ul style="list-style-type: none">• [Scalar Output] · Scalable analog output variable• Scalar Input · Scalable analog input variable• Discrete Output• Discrete Input
RES:	HW_REVISION (66) Storage class S; read capability r Hardware release for electronics and mechanics
RES:	ITK_VER (41) Storage class S Version of the Interoperability Tester Kit on which the interoperability testing is based.
RES:	LIM_NOTIFY (32) Storage class S; read/write capability r/w; supported modes O/A Number of unconfirmed event reports simultaneously supported by the device. <ul style="list-style-type: none">• 0 to [40]
RES:	LOCAL_OP_ENA (79) Storage class N; read/write capability r/w; supported modes O/A Locks on-site operation

RES:	MANUFAC_ID (10) Storage class S; read capability r Manufacturer ID • [0 x 00E099] · SAMSON AG
RES:	MAX_NOTIFY (31) Storage class S; read capability r Number of unconfirmed event reports simultaneously supported by the device. • [40]
RES:	MEMORY_SIZE (22) · This parameter is not supported.
RES:	MIN_CYCLE_T (21) Storage class S; read capability r Shortest cycle time that the device can perform. • [8000 · ms]
RES:	MODE_BLK (5) Storage class N; read/write capability r/w; supported modes O/A Mode of the Resource Block – Target Mode → Code 48 S0 – Actual Mode (read only) → Code 48 S1 – Permitted Mode – Normal Mode (read only) • AUTO · The execution of the function blocks (AO and PID) is enabled. • O/S · The execution of the function blocks (AO and PID) is stopped. These blocks go out of service (O/S mode).
RES:	NV_CYCLE_T (23) Storage class S; read capability r Time interval in which device data are stored to the non-volatile memory. Note: Non-volatile data are saved immediately after transmission.

RES: READING_DIRECTION (77)

Storage class D; read/write capability r/w; supported modes O/A

Reading direction → Code 2

The reading direction of the display is turned by 180°

- [Pneum. connection right]
- Pneum. connection left

RES: RESTART (16)

Storage class D; read/write capability r/w; supported modes O/A

Resetting the positioner

- RUN · Normal operating status
- RESOURCE (setting not supported)
- DEFAULTS · Resets device data and interconnection of function blocks to the values defined in the FF specification.
- PROCESSOR · Soft reset of the device, processor restart

RES: RS_STATE (7)

Storage class D; read capability r

Current operating status of the Resource Block

- ONLINE · Normal operating state; the function block is in AUTO mode.
- STANDBY · The Resource Block is in O/S mode.
- ONLINE LINKING · The configured links between the function blocks have not been established yet.

RES: SELECT_USAGE_IO (80)

Storage class N; read/write capability r/w; supported modes O

SELECT_DI_1 · Data for processing in the DI1 Function Block

- [5-30 VDC] · State of the standard binary contact BI1 (terminals +87/-88)
 - 0 Input voltage $U_e < 3 \text{ V DC}$
 - 1 Input voltage $U_e > 5 \text{ V DC}$
- INT.SOL.VLVE · Switching state of the internal solenoid valve
 - 0 Solenoid valve de-energized ($U < 15 \text{ V DC}$)
 - 1 Solenoid valve energized ($U > 19 \text{ V DC}$)

- DIS.FVLVE.POS · Current valve position as discrete information
 - 0 Device not initialized
 - 1 Current valve position < x %
 - 2 Current valve position > x %
 - 3 Intermediate position

Note: The limits for < x % and > x % are set in FINAL_POSITION_VALUE_LIMITS [0.5; 99.5]
 - COND.STATE · Current condensed state
 - 0 OK
 - 1 Maintenance required
 - 2 Maintenance demanded
 - 3 Maintenance alarm
 - 7 Function check
- SELECT_DI_2 · Data for processing in the DI2 Function Block
- FI_CONTACT · State of the standard binary contact BI2 (terminal +85/-86)
 - 0 Floating contact open
 - 1 Floating contact closed
 - INT.SOL.VLVE · Switching state of the internal solenoid valve
 - 0 Solenoid valve de-energized (U < 15 V DC)
 - 1 Solenoid valve energized (U > 19 V DC)
 - DIS.FVLVE.POS · Current valve position as discrete information
 - 0 Device not initialized
 - 1 Current valve position < x %
 - 2 Current valve position > x %
 - 3 Intermediate position

Note: The limits for < x % and > x % are set in FINAL_POSITION_VALUE_LIMITS [0.5; 99.5]
 - COND.STATE · Current condensed state
 - 0 OK
 - 1 Maintenance required
 - 2 Maintenance demanded
 - 3 Maintenance alarm
 - 7 Function check

- [COND.STATE + VST] · Current condensed state and start of the VST (Valve Stroke Test). See setting in VST_MODE parameter in the AO TRD Block.

SELECT_DO_1 · Purpose of the DO1 Function Block

- DO1 O/C · On/off service
- [VST] · Start of the VST (Valve Stroke Test). See setting in VST_MODE parameter in the AO TRD Block.
- RESET DIAG · Reset diagnosis (resetting of statistical information and tests, the classification of status messages and logging remain saved)
- RESET LOGGER · Reset logging
- F-SAFE · Move to fail-safe position
- DLOG · Data logger (0 Start; 1 Stop)
- LOG WRITE PR · Lock on-site operation (LOCAL_OP_ENA)
- DIAGNOSIS · Reset/stop diagnosis
 - 1 Reset diagnosis
 - 2 Reset logging
 - 3 Stop diagnosis
 - 4 Enable/start diagnosis

SELECT_DO_2 · Purpose of the DO2 Function Block

- VST · Start of the VST (Valve Stroke Test). See setting in VST_MODE parameter in the AO TRD Block.
- RESET DIAG · Reset diagnosis (resetting of statistical information and tests, the classification of status messages and logging remain saved)
- RESET LOGGER · Reset logging
- [F-SAFE] · Move to fail-safe position
- DLOG · Data logger (0 Start; 1 Stop)
- LOG WRITE PR · Lock on-site operation (LOCAL_OP_ENA)
- DIAGNOSIS · Reset/stop diagnosis
 - 1 Reset diagnosis
 - 2 Reset logging
 - 3 Stop diagnosis
 - 4 Enable/start diagnosis

SELECT_MAI_OUT_1 to SELECT_MAI_OUT_8 · Measured variable provided at the output OUT_1...OUT_8 of the MAI Function Block

- VALVE POS · Current valve position

- INTERNAL_TEMP · Current temperature inside the positioner
- PST_AUTOSTART_READ · Time until next automatic PST start

Default settings:

[VALVE POS] in SELECT_MAI_OUT_1, SELECT_MAI_OUT_4, SELECT_MAI_OUT_7

[INTERNAL_TEMP] in SELECT_MAI_OUT_2, SELECT_MAI_OUT_5, SELECT_MAI_OUT_8

[NEXT_AUTOSTART_READ] in SELECT_MAI_OUT_3, SELECT_MAI_OUT_6

SELECT_MAO_IN_1 to SELECT_MAO_IN_8 · Signal to be processed over the input IN_1... IN_8 of the MAO Function Block

- FLOW SENSOR
- P1 · Pressure p1
- P2 · Pressure p2
- PROC TEMP · Process temperature

Default settings:

[FLOW SENSOR] in SELECT_MAO_IN_1, SELECT_MAO_IN_5

[P1] in SELECT_MAO_IN_2, SELECT_MAO_IN_6

[P2] in SELECT_MAO_IN_3, SELECT_MAO_IN_7

[PROC TEMP] in SELECT_MAO_IN_4, SELECT_MAO_IN_8

RES: SET_FSTATE (29)

Storage class D; read/write capability r/w; supported modes O/A

Activation of the fault state in the AO Function Block

RES: SHED_RCAS (26)

Storage class S; read/write capability r/w; supported modes O/A

Monitoring time to check connection between fieldbus host system and PID Function Block in RCAS mode

When the monitoring time has elapsed, the PID Function Block switches from RCAS to the mode selected in the SHED_OPT parameter.

- [640000 · ms]

RES: SHED_ROUT (27)

Storage class S; read/write capability r/w; supported modes O/A

Monitoring time to check connection between fieldbus host system and PID Function Block in ROUT mode

When the monitoring time has elapsed, the PID Function Block switches from ROUT to the mode selected in the SHED_OPT parameter.

- [640000 · ms]

RES:	<p>STRATEGY (3) Storage class S; read/write capability r/w; supported modes O/A</p> <p>Permits strategic grouping and thus faster processing of blocks</p> <ul style="list-style-type: none"> • [0] <p>Blocks are grouped by entering the same number in the STRATEGY parameter of each block.</p> <p>Note: These data are neither checked nor processed by the Resource Block.</p>
RES:	<p>ST_REV (1) Storage class N; read capability r</p> <p>Static revision number</p> <p>Note: The revision number is incremented with each change of a static parameter in the block.</p>
RES:	<p>TAG_DESC (2) Storage class S; read/write capability r/w; supported modes O/A</p> <p>User-specific text for unique identification and assignment of the block</p> <ul style="list-style-type: none"> • Max. 32 characters, [no text]
RES:	<p>TEST_RW (8) Storage class D; read/write capability r/w; supported modes O/A</p> <p>This parameter is required for conformity tests only and is not relevant for normal operation.</p>
RES:	<p>TEXT_INPUT_1 (72) to TEXT_INPUT_5 (76) Storage class N; read/write capability r/w; supported modes O/A</p> <p>Any text</p> <ul style="list-style-type: none"> • Max. 32 characters, [no text]
RES:	<p>UPDATE_EVT (35) Storage class D; read capability r</p> <p>Indicates whether static data have been changed, including date and time stamp</p>
RES:	<p>WRITE_ALM (40) Storage class D; read/write capability r/w; supported modes O/A</p> <p>Status of write protection alarm</p> <p>Note: The alarm is triggered when write protection is deactivated.</p>

RES:	<p>WRITE_LOCK (34)</p> <p>Storage class S; read/write capability r/w; supported modes O/A</p> <p>Status of the write protection switch → Code 47</p> <ul style="list-style-type: none"> • LOCKED · Write protection activated • NOT LOCKED · Write protection deactivated <p>Note: The write-lock can be activated by setting Code 47 to ON: device data can only be read over FOUNDATION™ fieldbus communication, but not overwritten.</p> <p>The write-lock can be deactivated by setting Code 47 to OFF: device data can be overwritten over FOUNDATION™ fieldbus communication.</p>
RES:	<p>WRITE_PRI (39)</p> <p>Storage class S; read/write capability r/w; supported modes O/A</p> <p>Behavior upon a write-lock alarm (WRITE_ALM parameter)</p> <ul style="list-style-type: none"> • [0] · The write-lock alarm is not processed • 1 · The write-lock alarm is not broadcast to the fieldbus host system. • 2 · Reserved for block alarms • 3 to 7 · The write-lock alarm is issued to notify the operator with the corresponding priority: (3 = low, 7 = high) • 8 to 15 · The write-lock alarm is issued as a critical alarm with the corresponding priority: (8 = low, 15 = high)

Index and parameter assignment: Resource Block

Index	Parameters
0	RESOURCE_BLOCK_2
1	ST_REV
2	TAG_DESC
3	STRATEGY
4	ALERT_KEY
5	MODE_BLK
6	BLOCK_ERR
7	RS_STATE
8	TEST_RW
9	DD_RESOURCE
10	MANUFAC_ID
11	DEV_TYPE

Index	Parameters
12	DEV_REV
13	DD_REV
14	GRANT_DENY
15	HARD_TYPES
16	RESTART
17	FEATURES
18	FEATURE_SEL
19	CYCLE_TYPE
20	CYCLE_SEL
21	MIN_CYCLE_T
22	MEMORY_SIZE
23	NV_CYCLE_T

Parameter lists

Index	Parameters
24	FREE_SPACE
25	FREE_TIME
26	SHED_RCAS
27	SHED_ROUT
28	FAULT_STATE
29	SET_FSTATE
30	CLR_FSTATE
31	MAX_NOTIFY
32	LIM_NOTIFY
33	CONFIRM_TIME
34	WRITE_LOCK
35	UPDATE_EVT
36	BLOCK_ALM
37	ALARM_SUM
38	ACK_OPTION
39	WRITE_PRI
40	WRITE_ALM
41	ITK_VER
42	FD_VER
43	FD_FAIL_ACTIVE
44	FD_OFFSPEC_ACTIVE
45	FD_MAINT_ACTIVE
46	FD_CHECK_ACTIVE
47	FD_FAIL_MAP
48	FD_OFFSPEC_MAP
49	FD_MAINT_MAP
50	FD_CHECK_MAP
51	FD_FAIL_MASK
52	FD_OFFSPEC_MASK
53	FD_MAINT_MASK

Index	Parameters
54	FD_CHECK_MASK
55	FD_FAIL_ALM
56	FD_OFFSPEC_ALM
57	FD_MAINT_ALM
58	FD_CHECK_ALM
59	FD_FAIL_PRI
60	FD_OFFSPEC_PRI
61	FD_MAINT_PRO
62	FD_CHECK_PRI
63	FD_SIMULATE
64	FD_RECOMMEN_ACT
65	FIRMWARE_REVISION
66	HW_REVISION
67	DEVICE_SER_NUM
68	DEVICE_CERTIFICATION
69	DESCRIPTOR
70	DEVICE_MESSAGE
71	DEVICE_PRODUCT_NUM
72	TEXT_INPUT_1
73	TEXT_INPUT_2
74	TEXT_INPUT_3
75	TEXT_INPUT_4
76	TEXT_INPUT_5
77	READING_DIRECTION
78	BUS_ADDRESS
79	LOCAL_OP_ENA
80	SELECT_USAGE_IO
81	CONDENSED_STATE
82	DIAG_CLS
84	ALL_ACTIVE_STATUS_MESSAGES

9.1 Advanced Positioner Transducer Block (AO TRD)

AO TRD:	ACT_FAIL_ACTION (38) Storage class S; read/write capability r/w The fail-safe action of the actuator in the event of a supply air failure is detected automatically during initialization. <ul style="list-style-type: none"> • Air to open (in 0 % position) • Air to close (in 100 % position)
AO TRD:	ACT_MAN_ID (39) Storage class S; read/write capability r/w; supported modes O/M/A Actuator manufacturer Identifies the manufacturer of the actuator associated with the positioner
AO TRD:	ACT_MODEL_NUM (40) Storage class S; read/write capability r/w; supported modes O/M/A Type of the actuator associated with the positioner
AO TRD:	ACT_SN (41) Storage class S; read/write capability r/w; supported modes O/M/A Serial number of the actuator associated with the positioner
AO TRD:	ALARM_OPTION (101) Storage class S; read/write capability r/w Alarm setting to activate an output error in AO Function Block <ul style="list-style-type: none"> • No (never) · No • Local Override · Alarm triggered when the AO TRD is in the LOCAL OVERRIDE mode, i.e. the positioner is set locally in the SAFE mode or an internal solenoid valve is activated. • MAN · Alarm triggered when AO TRD is in MAN mode. • Block Alarm · Alarm triggered when the AO TRD has a MAINTENANCE NOW block error • AO TRD fault state · Alarm triggered when the fault state is active. • AO O/S set fault state · Alarm triggered when the AO Function Block in the O/S mode, the valve is moved to the FSTATE_VAL of the AO Function Block.

AO TRD: ALERT_KEY (4)
Storage class S; read/write capability r/w
ID number of the plant section
<ul style="list-style-type: none"> • 1 to 255, [0]
May be used by the fieldbus host system to sort alarms and events.
Note: '0' is not permissible and will be rejected when transferring data to the device (error alarm).
AO TRD: ANALYSIS_OPEN_CLOSE (147)
Storage class D; read capability r
Statistical information > Open/Close
Reference analysis and the last two test analyses (► EB 8389 (EXPERTplus valve diagnostics))
<ul style="list-style-type: none"> • TIME_STAMP_RISING/FALLING • BREAK_AWAY_TIME_RISING/FALLING • TRANSIT_TIME_RISING/FALLING • VALVE_END_POSITION_RISING/FALLING
AO TRD: APPLICATION_TYPE_OC_CONTROL (144)
Storage class S; read/write capability r/w; supported modes O/M/A
Application type (valve)
<ul style="list-style-type: none"> • Control Valve • Open/Close (on/off) Valve
AO TRD: AUTOMATIC_TEST_STATUS (175)
Storage class S; read/write capability r/w; supported modes O/M/A
Status of active test: drive signal diagram steady (d1 test)
Drive signal diagram hysteresis (d2 test)
Static characteristic (d3 test)
Partial stroke test (PST) (d4 test)
AO TRD: BINARY_INPUT_2 (111)
Storage class D; read capability r
State of DI2 Function Block
The value issued depends on CONFIG_BINARY_INPUT_2.

AO TRD: BLOCKING_POSITION (124)
Storage class S; read/write capability r/w; supported modes O/M/A
Blocking position → Code 35
Distance to CLOSED position (0 % position)
Note: Only necessary with SUB initialization mode.
AO TRD: BLOCK_ALM (8)
Storage class D; read/write capability r/w
Current block state with details on all configuration, hardware or system problems in the block including date and time stamp.
AO TRD: BLOCK_ERR (6)
Storage class D; read capability r
Active block errors → Code 48 S2
<ul style="list-style-type: none"> • SIMULATE ACTIVE · Simulation jumper active, simulation possible • OUT OF SERVICE · Block mode is out of service • LOST STATIC DATA · Data loss in EEPROM • DEVICE NEEDS MAINTENANCE SOON · Maintenance required soon. This message triggers a block alarm (BLOCK_ALM) in the AO TRD Block. • DEVICE NEEDS MAINTENANCE NOW · Maintenance required now. This message triggers a block alarm (BLOCK_ALM) in the AO TRD Block.
Note: The assignment of error or diagnostic alarms to the desired function block is made using the ERROR_OPTION parameters in the Transducer Block.
AO TRD: CHARACTERIZATION (91)
Storage class S; read/write capability r/w; supported modes O/M/A
Characteristic selection → Code 20
1 Linear
2 Equal percentage
3 Equal percentage reverse
4 SAMSON butterfly linear
5 SAMSON butterfly equal percentage
6 VETEC rotary linear
7 VETEC rotary equal percentage
8 Segmented ball valve linear
9 Segmented ball valve (equal) percentage
10 User defined
Definition using AO TRD (CUSTOM_CURVE_XY_FLOAT (63))

Parameter lists

AO TRD: CLOSED_POS_DEADBAND (61)
Storage class S; read/write capability r/w
Zero limit [%] → Code 48 d5
AO TRD: CLOSED_POS_SHIFT (62)
Storage class N; read capability r
Lower end position shift
AO TRD: CLOSING_DIRECTION (121)
Storage class S; read/write capability r/w; supported modes O/M/A
Closing direction → Code 34
Lever's direction of rotation for travel pick-off which causes the CLOSED position (0 % position) of the control valve to be reached.
Note: Only necessary with SUB initialization mode.
AO TRD: CONFIG_BINARY_INPUT_2 (110)
Storage class S; read/write capability r/w; supported modes O/M/A
Sets the logical state of DI2
<ul style="list-style-type: none">• [NOT EVALUATED]• ACTIVELY OPEN• ACTIVELY CLOSED• ACTIVELY OPEN – LEAKAGE SENSOR• ACTIVELY CLOSED – LEAKAGE SENSOR
Note: The parameter is processed by the BINARY_INPUT_2 parameter. The parameter settings do not depend on DI2 Transducer Block.
AO TRD: COUNTER_INIT_START (138)
Storage class D; read capability r
The total number of initializations that have been performed since the last reset → Code 48 d4
AO TRD: CUSTOM_CURVE_DESCRIPTION (63) · This parameter is not supported.
AO TRD: CUSTOM_CURVE_XY_FLOAT (65)
Storage class S; read/write capability r/w; supported modes O/M/A
Enter the user-defined characteristic

AO TRD:	CYCLE_CNTR (33) Storage class D; read capability r Number of measured cycles since the counter was last reset
AO TRD:	CYCLE_CNTR_LIM (76) Storage class S; read/write capability r/w; supported modes O/M/A Maximum cycle counter limit for user-defined settings (selected through Stuffing box/ Other)
AO TRD:	DEPTXE (173) Storage class D; read capability r Statistical information > Trend of travel end position > Lower end position Characteristic of the lower end position
AO TRD:	DEPTXR (174) Storage class D; read capability r Statistical information > Trend of travel end position > Lower end position Reference characteristic of the lower end position
AO TRD:	DEVIATION_DEADBAND (21) Storage class S; read/write capability r/w; supported modes O/M/A Tolerance band relating to the operating range → Code 190 • 1 to 10.0 %, [5.0 %]
AO TRD:	DEVIATION_MAX (105) Storage class D; read capability r Max. set point deviation of the positioner that has occurred
AO TRD:	DEVIATION_MIN (104) Storage class D; read capability r Min. set point deviation of the positioner that has occurred
AO TRD:	DEVIATION_TIME (22) Storage class S; read/write capability r/w; supported modes O/M/A Lag time (resets active control loop monitoring) • 1 to 240 s, [10 s] A control loop error is reported when entered lag time (DEVIATION_TIME) is exceeded and the set point deviation is not within the entered tolerance band (DEVIATION_DEADBAND). Note: The DEVIATION_TIME value is determined during initialization from the minimum transit time.

Parameter lists

AO TRD: DEVIATION_VALUE (23)
Storage class D; read capability r
Set point deviation $e \rightarrow$ Code 39
AO TRD: DEVICE_INIT_STATE (120)
Storage class D; read capability r
Indicates whether the device has been initialized.
AO TRD: DEVICE_STATUS_INIT (121)
Storage class D; read capability r
Status of initialization in progress
AO TRD: DIAG_LEVEL (132)
Storage class D; read capability r
Existing diagnostic level: EXPERTplus
AO TRD: DIAG_REFLAUF_INFO (176)
Storage class S; read capability r
Status of the reference tests in progress
AO TRD: DIAG_RESET_AFTER_TIME (142)
Storage class S; read/write capability r/w; supported modes O/M/A
Time until the next single reset of the diagnosis
AO TRD: DIAG_RESET_AFTER_TIMEOUT (143)
Storage class S; read capability r
Time remaining until the next single reset of the diagnosis
AO TRD: DSKV1 (194) to DSKV4 (197)
Storage class D; read capability r
Tests/Static characteristic
Measured valve position x values of the characteristic
AO TRD: DSKW1 (198) to DSKW4 (201)
Storage class D; read capability r
Tests/Static characteristic
Measured set point w values of the characteristic

AO TRD:	DSXHTW (191) Storage class D; read capability r Tests > Drive signal diagram hysteresis (d2 test) Measured valve position x values of the characteristic of the last performed test
AO TRD:	DSXSTR (182) Storage class D; read capability r Tests > Drive signal diagram steady (d1 test) Measured valve position x values of the reference characteristic
AO TRD:	DSXSTW (184) Storage class D; read capability r Tests > Drive signal diagram steady (d1 test) Measured valve position x values of the characteristic of the last performed test
AO TRD:	DSYHTR (189) Storage class D; read capability r Tests > Drive signal diagram hysteresis (d2 test) Measured valve position x values of the reference characteristic
AO TRD:	DSYHTW (190) Storage class D; read capability r Statistical information > Drive signal diagram > Hysteresis Mean values of drive signal changes (long-term monitoring)
AO TRD:	DSYSK (157) Storage class D; read capability r Statistical information > Drive signal diagram > Steady Measured values of the characteristic, drive signal (short-term monitoring)
AO TRD:	DSYSL (156) Storage class D; read capability r Statistical information > Drive signal diagram > Steady Measured values of the characteristic, drive signal (long-term monitoring)
AO TRD:	DSYSS (158) Storage class D; read capability r Statistical information > Drive signal diagram > Steady Shows last ten measured drive signal values (belonging to DIAGR_VALVE_POS_STAT_SHORT)

AO TRD: DSYSTR (181)
Storage class D; read capability r
Tests > Drive signal diagram hysteresis (d2 test)
Measured drive signal y values of the reference characteristic
AO TRD: DSYSTW (183)
Storage class D; read capability r
Tests > Drive signal diagram steady (d1 test)
Measured drive signal y values of the reference characteristic
AO TRD: DVPSS (159)
Storage class D; read capability r
Statistical information > Drive signal diagram > Steady
Shows last ten measured valve position values (belonging to DIAGR_STELL_Y_STAT_SHORT)
AO TRD: EHM (136)
Storage class D; read capability r
Operating hours counter
<ul style="list-style-type: none"> • ELAPSED_HOURS_TOTAL · Device switched on • ELAPSED_HOURS_IN_CLOSED_LOOP • ELAPSED_HOURS_SWITCHED_ON_SINCE_INIT · Device switched on since last initialization • ELAPSED_HOURS_IN_CLOSED_LOOP_SINCE_INIT · Device in closed-loop operation since last initialization
AO TRD: END_POS_TREND_REF_DRIVE_SIG_REF (168)
Storage class D; read capability r
Statistical information > Trend of travel end position > Lower end position
Reference value of the lower end position (drive signal y)
AO TRD: END_POS_TREND_REF_TIME_REF (167)
Storage class D; read capability r
Statistical information > Trend of travel end position > Lower end position
Reference value of the lower end position (time stamp)
AO TRD: END_POS_TREND_REF_VALUES_REF (166)
Storage class D; read capability r
Statistical information > Trend of travel end position > Lower end position
Reference value of the lower end position (valve position x)

AO TRD:	EPTRDS (171) Storage class D; read capability r Statistical information > Trend of travel end position > Lower end position Reading of the last 30 lower end positions (drive signal y)
AO TRD:	EPTRT (170) Storage class D; read capability r Statistical information > Trend of travel end position > Lower end position Reading of the last 30 lower end positions (time stamp)
AO TRD:	EPTRV (169) Storage class D; read capability r Statistical information > Trend of travel end position > Lower end position Reading of the last 30 lower end positions (valve position x)
AO TRD:	EVENT_LOGGING_1 (139) EVENT_LOGGING_2 (140) Storage class D; read capability r <ul style="list-style-type: none"> • EVENT_LOGGING_1: indicates event logs 0 – 14 with the time they were recorded • EVENT_LOGGING_2: indicates event logs 15 – 29 with the time they were recorded
AO TRD:	FINAL_POSITION_VALUE (18) Storage class D; read capability r Current valve position after taking rescaling into account
AO TRD:	FINAL_POSITION_VALUE_D (50) Storage class D; read capability r Current discrete valve position after taking the direction of action into account
AO TRD:	FINAL_POSITION_VALUE_LIMITS (131) Storage class S; read/write capability r/w Limit of the valve position (FINAL_POSITION_VALUE) <ul style="list-style-type: none"> • FINAL_POSITION_VALUE_LIMITS • FINAL_POSITION_VALUE_HIGH_LIMIT • FINAL_POSITION_VALUE_LOW_LIMIT This variable is sent to the AO Transducer Block directly from the valve

AO TRD: FINAL_VALUE (14)
Storage class S; read/write capability r/w; supported modes O/M
Positioning value TRD
FINAL_VALUE contains the positioning value received from the upstream AO Function Block.
Scaling over FINAL_VALUE_RANGE
AO TRD: FINAL_VALUE_CUTOFF_HI (16)
Storage class S; read/write capability r/w; supported modes O/M/A
Setpoint cutoff increase → Code 15
<ul style="list-style-type: none"> • 50 to 100 %, [100 %]
If the set point exceeds the entered value, the valve is moved towards the end position (corresponding to 100 % of the output value). To do so, the actuator is either completely filled with air or completely vented depending on the fail-safe action.
Note: The function is deactivated by entering -2.5 %.
NOTICE The control valve moves to its final end position as this function causes the actuator to be either fully vented or filled with air. Restrictions determined by the travel range or travel stop function do not apply. Deactivate this function if excessive thrust may arise as a result.
AO TRD: FINAL_VALUE_CUTOFF_HI_ON (123)
Storage class S; read/write capability r/w; supported modes O/M/A
Enable setpoint cutoff increase → Code 15
AO TRD: FINAL_VALUE_CUTOFF_LO (17)
Storage class S; read/write capability r/w; supported modes O/M/A
Setpoint cutoff decrease → Code 14
<ul style="list-style-type: none"> • 0 to 50 %, [1 %]
If the set point falls below the entered value, the valve is moved towards the end position (corresponding to 0 % of the output value). To do so, the actuator is either completely filled with air or completely vented depending on the fail-safe action.
Note: The function is deactivated by entering 0 %.
NOTICE The control valve moves to its final end position as this function causes the actuator to be either fully vented or filled with air. Restrictions determined by the travel range or travel stop function do not apply. Deactivate this function if excessive thrust may arise as a result.
AO TRD: FINAL_VALUE_CUTOFF_LO_ON (122)
Storage class S; read/write capability r/w; supported modes O/M/A
Enable setpoint cutoff decrease → Code 14

AO TRD:	FINAL_VALUE_D (49) Storage class S; read/write capability r/w; supported modes O/M Discrete set point of upstream DO1 Function Block
AO TRD:	FINAL_VALUE_RANGE (15) Storage class S; read/write capability r/w; supported modes O Travel/angle range <ul style="list-style-type: none"> • FINAL VALUE RANGE EU_100 · Travel/angle range end → Code 9 • FINAL VALUE RANGE EU_0 · Travel/angle range start → Code 8 • FINAL VALUE RANGE UNITS_INDEX · Unit • FINAL VALUE RANGE DECIMAL · Decimal point <p>Note: FINAL_VALUE is sent to the AO Transducer Block directly from an upstream AO Function Block.</p> <p>The FINAL_VALUE_RANGE operating range is compared on entering it with TRANS_PIN_POS. If the TRANS_PIN_POS parameter is changed, the positioner checks whether the setting and unit match the current operating range FINAL_VALUE_RANGE. If this is not the case, the FINAL_VALUE_RANGE operating range is set to 0 to 100 %.</p>
AO TRD:	FRICION (68) Storage class N; read capability r Determined friction in percent
AO TRD:	FRICION_LIMITS (265) Storage class S; read/write capability r/w; supported modes O/M/A Upper/lower friction limits <ul style="list-style-type: none"> • FRICTION_LIMIT_UP, 0 to 1000 % [200 %] • FRICTION_LIMIT_DOWN, 0 to 1000 % [50 %]
AO TRD:	FRICION_UNITS (67) · This parameter is not supported.
AO TRD:	FST_BREAKOUT_TIME (86) Storage class S; read capability r Breakaway time determined during the last full stroke test (FST)
AO TRD:	FST_BREAKOUT_TIMEOUT (87) Storage class S; read/write capability r/w; supported modes O/M/A Cancellation conditions of the full stroke test (FST): maximum breakaway time <ul style="list-style-type: none"> • 0.0 to 25000.0 s, [7.5 s]

<p>AO TRD: FST_COMPLETION_TIMEOUT (90) Storage class S; read/write capability r/w; supported modes O/M/A Cancellation conditions of the full stroke test (FST): maximum test duration (user-defined)</p> <ul style="list-style-type: none"> • 0.0 to 25000.0 s, [30.0 s]
<p>AO TRD: FST_DIAGR_E1 (257) to FST_DIAGR_E4 (260) Storage class D; read capability r Statistical information > Data logger: Measured set point deviation (e) values</p>
<p>AO TRD: FST_DIAGR_TIME1 (245) to FST_DIAGR_TIME4 (248) Storage class D; read capability r Tests > Full stroke test (FST): Measured time (t) values</p>
<p>AO TRD: FST_DIAGR_W1 (253) to FST_DIAGR_W4 (256) Storage class D; read capability r Statistical information > Data logger: Measured set point (w) values</p>
<p>AO TRD: FST_DIAGR_X1 (249) to FST_DIAGR_X4 (252) Storage class D; read capability r Statistical information > Data logger: Measured valve position (x) values</p>
<p>AO TRD: FST_DIAGR_Y1 (261) to FST_DIAGR_Y4 (264) Storage class D; read capability r Statistical information > Data logger: Measured drive signal (y) values</p>
<p>AO TRD: FST_DISPLAY (238) Storage class D; read capability r Information on the full stroke test (FST)</p> <ul style="list-style-type: none"> • FST_PROGRESS_FLAG · Current progress of the test • FST_STATUS_PST · Status (successful/not successful) • FST_NUMBERS_OF_TESTS · Number of full stroke tests performed • FST_SETTINGS_MIN_SCAN_RATE · Recommended min. scan rate • FST_SETTINGS_DURATION_TEST · Expected duration of test

AO TRD: FST_MEAS_DATA1 (239) to FST_MEAS_DATA3 (241)

Storage class D; read capability r

Measured data assessment of the full stroke test (FST)

FST_MEAS_DATA1 (271) = Current test

FST_MEAS_DATA2 (272) = First measured data assessment saved

FST_MEAS_DATA3 (273) = Second measured data assessment saved

- FST_TIME_STAMP · Time stamp for this test
- FST_OVERSHOOT_RISING · Overshoot (rising)
- FST_DEAD_TIME_RISING · Dead time (rising)
- FST_T63_RISING · T63 (rising)
- FST_T98_RISING · T98 (rising)
- FST_RISE_TI_RISING · Rise time (rising)
- FST_SETTL_TI_RISING · Settling time (rising)
- FST_OVERSHOOT_FALLING · Overshoot (falling)
- FST_DEAD_TI_FALLING · Dead time (falling)
- FST_T68_FALLING · T63 (falling)
- FST_T98_FALLING · T98 (falling)
- FST_RISE_T_FALLING · Rise time (falling)
- FST_SETTL_T_FALLING · Settling time (falling)

AO TRD: FST_RAMP_RATE (88) · This parameter is not supported.**AO TRD: FST_SETTINGS (237)**

Storage class D; read/write capability r/w; supported modes O/M/A

Settings for the full stroke test (FST)

- FST_TOL_LIMIT_RESPONSE · Tolerance limit for step start/end values
- FST_ACTIV_RAMP_FUNCTION · Activate ramp function
- FST_RAMP_TIME_RISING · Ramp time (rising)
- FST_RAMP_TIME_FALLING · Ramp time (falling)
- FST_SETTLING_TIME · Settling time before starting test
- FST_SCAN_RATE

AO TRD: FST_STRK_TRAV_TIMEOUT (89)

Storage class S; read/write capability r/w; supported modes O/M/A



Cancellation conditions of the full stroke test (FST): perm. time until step end 0.0 to 25000 s, [15.0 s]

AO TRD: FST_TEST_INFO (235)
Storage class D; read capability r
Current status of the full stroke test (FST)
AO TRD: FST_TEST_STAT1 (274) to FST_TEST_STAT3 (276)
Storage class D; read capability r
Status of the full stroke test (FST)
FST_TEST_STAT1 (274) = Current test
FST_TEST_STAT2 (275) = First saved status
FST_TEST_STAT3 (276) = Second saved status
<ul style="list-style-type: none"> • FST_NO_TEST_AVAILABLE · No test available • FST_MAX_TIME_EXCEEDED · Max. test duration exceeded • FST_TEST_MANUA_CANCEL · Test canceled manually • FST_OUT_OF_MEMORY · Measured data memory full • FST_ABO_INT_SOL_VALVE · Canceled due to internal solenoid valve/forced venting • FST_PRESSURE_FRICTION · Canceled due to supply air/friction • FST_CURRENT_TOO_LOW · Test canceled, insufficient current
AO TRD: HIST (135)
Storage class D; read capability r
Reading in hours (or part thereof)
<ul style="list-style-type: none"> • HIS_T_ZEIT_MIN_TEMPERATURE · Operating hours counter: lowest temperature inside the positioner • HIS_T_ZEIT_MAX_TEMPERATURE · Operating hours counter: highest temperature inside the positioner • TEMP_PERIOD_TIME_LOW · Time the temperature remained below -40 °C (-40 °F) • TEMP_PERIOD_TIME_HIGH · Time the temperature remained above +80 °C (+176 °F)
AO TRD: HISTOGR_X_SCAN_RATE (150)
Storage class D; read/write capability r/w; supported modes O/M/A
Statistical information > Short-term valve position x histogram: measured values and mean value
AO TRD: HISTOGR_X_SHORT (149)
Storage class D; read capability r
Statistical information > Short-term valve position x histogram: scan rate to record valve positions

AO TRD:	HXL (148) Storage class D; read capability r Statistical information > Long-term valve position x histogram: measured values, mean value, number of measuring points and observation period
AO TRD:	HYSTERESIS (69) · This parameter is not supported.
AO TRD:	HYST_SHORT_DIFF_Y (163) Storage class D; read capability r Statistical information > Drive signal diagram > Hysteresis: last ten measured values of drive signal difference (y) (belonging to HYST_VALVE_POS)
AO TRD:	HYST_VALVE_POS (164) Storage class D; read capability r Statistical information > Drive signal diagram > Hysteresis: last ten measured values of valve position (belonging to HYST_SHORT_DIFF_Y)
AO TRD:	IDENT_OPTIONS (108) Storage class D; read capability r Options (additional equipment) <ul style="list-style-type: none"> • 1 Internal solenoid valve • 2 Binary input 1 • 3 Binary input 2 • 4 Inductive limit contact • 5 Leakage sensor • 6 External position sensor
AO TRD:	INIT_METHOD (116) Storage class S; read/write capability r/w Initialization mode → Code 6 <ul style="list-style-type: none"> • 0 Maximum range (MAX) • 1 Nominal range (NOM) • 2 Manually selected range (MAN) • 3 Substitute calibration (SUB) • 4 Zero calibration

AO TRD:	INIT_WITH_REF_TEST (117) Storage class S; read/write capability r/w Record diagnostic reference tests during initialization. <ul style="list-style-type: none"> • Yes • [No]
AO TRD:	INTERNAL_TEMP (96) Storage class D; read capability r Current temperature inside the positioner
AO TRD:	INTERNAL_TEMP_MAX (98) Storage class D; read capability r Highest temperature measured inside the positioner
AO TRD:	INTERNAL_TEMP_MIN (97) Storage class D; read capability r Lowest temperature measured inside the positioner
AO TRD:	INTERNAL_TEMP_UNITS (99) Storage class S; read/write capability r/w; supported modes O/M/A Unit of temperature inside the positioner: [°C], °F
AO TRD:	KP_STEP (127) Storage class S; read/write capability r/w Proportional-action coefficient Kp level → Code 17 Note: This parameter can only be read over FOUNDATION fieldbus. The value is recorded during initialization.
AO TRD:	LIMIT_VALUE_TIME_ANALYSIS (145) Storage class S; read/write capability r/w; supported modes O/M/A Statistical information > Open/close: time limit for difference between reference value and currently recorded value Determines at which value a message is generated. <ul style="list-style-type: none"> • 0.0 to 30.0 s, [0.6 s]
AO TRD:	LIMIT_VALUE_TRAVEL_ANALYSIS (146) Storage class S; read/write capability r/w; supported modes O/M/A Statistical information > Open/close: travel limit for difference between reference value and currently recorded value Determines at which value a message is generated. <ul style="list-style-type: none"> • 0.0 ... 100.0 %, [0.3 %]

AO TRD:	LOGGING_MGV (106) Storage class S; read/write capability r/w; supported modes O/M/A Logging of the solenoid valve active (error control) <ul style="list-style-type: none"> • [Yes] • No
AO TRD:	LS_ALARM_INFORMATION (306) Storage class D; read capability r Leakage sensor: alarm information
AO TRD:	LS_ALARM_LIMIT_1 (270) to LS_ALARM_LIMIT_3 (272) Storage class S; read/write capability r/w Leakage sensor LS_ALARM_LIMIT_1 (307) = First alarm limit in dB LS_ALARM_LIMIT_2 (308) = Second alarm limit in dB LS_ALARM_LIMIT_3 (309) = Third alarm limit in dB
AO TRD:	LS_ALARM_RELEASE (304) Storage class S; read/write capability r/w; supported modes O/M/A Leakage sensor: alarm triggering <ul style="list-style-type: none"> • No alarm release · No alarm triggering • Average level at tight-closing · Mean sound level when tight closing • [Average of current/last tight-closing] · Mean of current/last tight closing • Moving average short-term histogram · Rolling mean from short-term histogram • Moving average long-term histogram · Rolling mean from long-term histogram
AO TRD:	LS_LEAKAGE_LEVEL (266) Storage class D; read capability r Leakage sensor: sensor level in dB
AO TRD:	LS_SELECT_ALARM_LIMITS (268) Storage class S; read/write capability r/w; supported modes O/M/A Leakage sensor: alarm limits <ul style="list-style-type: none"> • [Factory setting (reference test)] • Alarm limit of repetition test • User defined alarm limit

AO TRD: LS_TEST_INFORMATION (273)
Storage class D; read capability r
Leakage sensor: test status
AO TRD: MIN_CLEARANCE_NEW_LOGGING_MGV (107)
Storage class S; read/write capability r/w; supported modes O/M/A
Minimum time interval until logging of the internal solenoid valve restarts (error control)
AO TRD: MODE_BLK (5)
Storage class S; read/write capability r/w
Operating mode
– Target Mode → Code 48 t0
– Actual Mode (read only) → Code 48 t1
– Permitted Mode
– Normal Mode (read only)
• AUTO · A positioning value is calculated from the output value received from the AO Function Block and the control valve is positioned accordingly.
• O/S · The positioning value from the AO Function Block is not used. The control valve is moved to its mechanical fail-safe position entered in ACT_FAIL_ACTION. The mode is also changed to O/S when the forced venting function is activated.
• MAN · The positioning value (FINAL_VALUE) can be entered manually (reading at the positioner:  and )
• LO · AO TRD switches to LO mode if the positioner is switched to the MAN mode on site.
AO TRD: NO_OF_ZERO_POINT_ADJ (137)
Storage class D; read capability r
Number of zero calibrations performed since the last initialization → Code 48 d3
AO TRD: OPTI_SUB_INIT (119)
Storage class S; read/write capability r/w; supported modes O/M/A
Optimizes edges of substitute calibration
• ON
• [OFF]

AO TRD:	<p>PCC (207)</p> <p>Storage class S; read/write capability r/w; supported modes O/M/A</p> <p>Cancellation conditions of the partial stroke test (PST)</p> <ul style="list-style-type: none"> • PST_ACT_X_CONTROL · Activation of x cancellation condition • PST_X_CONTROL_VALUE · x control value • PST_ACT_DELTA_Y_MONI · Activation of y cancellation condition • PST_DELTA_Y_MONI_VAL · delta y-monitoring value • PST_TOL_BAND_CONTROL · Activate PST tolerance band monitoring • PST_TOL_BAND · PST tolerance band
AO TRD:	<p>PMD1 (209) to PMD3 (211)</p> <p>Storage class D; read capability r</p> <p>Measured data assessment of the partial stroke test (PST)</p> <p>PMD1 (209) = Current test</p> <p>PMD2 (210) = First measured data assessment saved</p> <p>PMD3 (211) = Second measured data assessment saved</p> <ul style="list-style-type: none"> • PST_TIME_STAMP · Time stamp for this test • PST_OVERSHOOT_RISING · Overshoot (rising) • PST_DEAD_TIME_RISING · Dead time (rising) • PST_T63_RISING · T63 (rising) • PST_T98_RISING · T98 (rising) • PST_RISE_TI_RISING · Rise time (rising) • PST_SETTL_TI_RISING · Settling time (rising) • PST_OVERSHOOT_FALLING · Overshoot (falling) • PST_DEAD_TI_FALLING · Dead time (falling) • PST_T63_FALLING · T63 (falling) • PST_T98_FALLING · T98 (falling) • PST_RISE_T_FALLING · Rise time (falling) • PST_SETTL_T_FALLING · Settling time (falling) • PST_DELTA_Y · delta y-monitoring (repetition value)
AO TRD:	<p>POSITIONER_MODEL (112)</p> <p>Storage class D; read capability r</p> <p>Positioner type</p>

AO TRD: POS_ALERT_HI (24)
Storage class S; read/write capability r/w; supported modes O/M/A
User-defined high limit which sets the high limit bit in WORKING_POS when the value is exceeded.
<ul style="list-style-type: none"> • [100 %]
AO TRD: POS_ALERT_LO (25)
Storage class S; read/write capability r/w; supported modes O/M/A
User-defined low limit which sets the low limit bit in WORKING_POS when the value falls below the limit.
<ul style="list-style-type: none"> • [0 %]
AO TRD: POS_DEADBAND (70) · This parameter is not supported.
AO TRD: POS_FEATURES (55)
Storage class D; read capability r
Parameter groups supported by AO TRD
AO TRD: PRESSURE_LIMIT (125)
Storage class S; read/write capability r/w
Pressure limit → Code 16
<ul style="list-style-type: none"> • [OFF] • 3.7 bar • 2.4 bar • 1.4 bar
AO TRD: PROTOKOLL_BSZ_START (141)
Storage class D; read capability r
Display the time since first start-up (operating hours counter)
AO TRD: PST_AUTOSTART_READ (203)
Storage class D; read capability r; supported modes O/M/A
Time until the next automatically performed partial stroke test (Auto PST)
AO TRD: PST_BREAKOUT_TIME (77)
Storage class N; read capability r
Breakaway time determined during the last partial stroke test (PST)

AO TRD:	PST_BREAKOUT_TIMEOUT (78) Storage class S; read/write capability r/w; supported modes O/M/A Cancellation conditions of the partial stroke test (PST): maximum breakaway time
AO TRD:	PST_COMPLETION_TIMEOUT (85) Storage class S; read/write capability r/w; supported modes O/M/A Cancellation conditions of the partial stroke test (PST): maximum test duration (user-defined)
AO TRD:	PST_DIAGR_E1 (227) to PST_DIAGR_E4 (230) Storage class D; read capability r Statistical information > Data logger: Measured set point deviation (e) values
AO TRD:	PST_DIAGR_TIME1 (215) to PST_DIAGR_TIME4 (218) Storage class D; read capability r Tests > Partial stroke test (PST): Measured time (t) values
AO TRD:	PST_DIAGR_W1 (223) to PST_DIAGR_W4 (226) Storage class D; read capability r Statistical information > Data logger: Measured set point (w) values
AO TRD:	PST_DIAGR_X1 (219) to PST_DIAGR_X4 (222) Storage class D; read capability r Statistical information > Data logger: Measured valve position (x) values
AO TRD:	PST_DIAGR_Y1 (231) to PST_DIAGR_Y4 (234) Storage class D; read capability r Statistical information > Data logger: Measured drive signal (y) values
AO TRD:	PST_DISPLAY (208) Storage class D; read capability r Information on the partial stroke test (PST) <ul style="list-style-type: none"> • PST_PROGRESS_FLAG · Current progress of the test • PST_MIN_VALUE_Y_CONTROL · delta y-monitoring (repetition value) • PST_DELTA_Y_MONI_REF_VAL · delta y-monitoring reference value • PST_STATUS_PST · Status (successful/not successful) • PST_NUMBERS_OF_TESTS · Number of partial stroke tests performed • PST_RECOMMENDED_SCAN_RATE · Recommended min. scan rate • PST_DURATION_OF_TEST · Expected duration of test • PST_TESTMODE_ACTUAL · Current PST mode

Parameter lists

AO TRD: PST_INITIAL_START_TIME (79) · This parameter is not supported.
AO TRD: PST_INTERVAL (80) Storage class S; read/write capability r/w; supported modes O/M/A Time until the automatic partial stroke test starts (PST_TESTMODE_TARGET must be set to 'PST Auto')
AO TRD: PST_OPTIONS (81) · This parameter is not supported.
AO TRD: PST_RAMP_RATE (82) · This parameter is not supported.
AO TRD: PST_SETTINGS (206) Storage class D; read/write capability r/w; supported modes O/M/A Settings of partial stroke test (PST) <ul style="list-style-type: none">• PST_STEP_START · Start value for step response• PST_STEP_END · End value for step response• PST_LIMIT_STEP_RESPONSE · Tolerance limit for step start/end values• PST_ACTIVATION_RAMP_FUNCTION · Activate ramp function• PST_ACTIVATION_RAMP_FUNCTION · Activate ramp function• PST_RAMP_TIME_RISING · Ramp time (rising)• PST_RAMP_TIME_FALLING · Ramp time (falling)• PST_SETTLING_TIME_BEFORE_TEST · Settling time before starting test• PST_SCAN_RATE• PST_STEP_RESPONSE · Number of step responses
AO TRD: PST_STRK_TRAV (83) Storage class S; read capability r Step height during partial stroke test (PST)
AO TRD: PST_STRK_TRAV_TIMEOUT (84) Storage class S; read/write capability r/w; supported modes O/M/A Cancellation conditions of the partial stroke test (PST): perm. time until step end

AO TRD:	PST_TESTMODE_TARGET (202) Storage class D; read/write capability r/w; supported modes O/M/A Target PST testing mode <ul style="list-style-type: none"> • [PST Man] • PST Auto
AO TRD:	PST_TEST_INFO (204) Storage class D; read capability r Current status of the partial stroke test (PST)
AO TRD:	PST_TEST_STAT1 (212) to PST_TEST_STAT3 (214) Storage class D; read capability r Status of the partial stroke test (PST) PST_TEST_STAT1 (212) = Current test PST_TEST_STAT2 (213) = First saved status PST_TEST_STAT3 (214) = Second saved status <ul style="list-style-type: none"> • PST_TEST_START • PST_NO_TEST_AVAILABLE · No test available • PST_X_CANCEL · x cancellation • PST_Y_CANCEL · y cancellation • PST_TOL_BAND_EXCEEDED • PST_MAX_TIME_EXCEEDED · Max. test duration exceeded • PST_TEST_MANUA_CANCEL · Test canceled manually • PST_OUT_OF_MEMORY · Measured data memory full • PST_ABO_INT_SOL_VALVE · Canceled due to internal solenoid valve/forced venting • PST_PRESSURE_FRICTION · Canceled due to supply air/friction • PST_W_STEP_TOO_HIGH · Set point difference, step start too high • PST_ABORT_REF_CHANGED · Test canceled, set point too high • PST_CURRENT_TOO_LOW · Test canceled, insufficient current
AO TRD:	RATED_TRAVEL (26) Storage class S; read/write capability r/w Nominal range → Code 5 <ul style="list-style-type: none"> • 0 to 255.9 mm, [15.0 mm] Note: The unit [mm] or [degrees] depends on the VALVE_TYPE parameter.

AO TRD: READBACK_SELECT (35)
Storage class S; read/write capability r/w
Select current or actual valve position for the READBACK parameter
<ul style="list-style-type: none"> • [FINAL_POSITION_VALUE] • WORKING_POS
AO TRD: REFLAUF_VOLLST (177)
Storage class D; read capability r
Reference tests completed
AO TRD: RESET_STATUS_MESSAGE_DIAG (134)
Storage class D; read/write capability r/w
Select reset command
<ul style="list-style-type: none"> • Single error message • Trends, histograms, test diagrams • PST/FST parameters and measured values • Logging • All recorded diagnostic data (except for reference graphs and logging)
AO TRD: SELECT_EMERGENCY_MODE (126)
Storage class S; read/write capability r/w
Behavior upon failure/defective travel sensor
<ul style="list-style-type: none"> • Open-loop control based on saved characteristic • Move to defined fail-safe position
AO TRD: SELO (109)
Storage class S; read/write capability r/w; supported modes O/M/A
Display/change installed options that are not automatically detected (IDENT_LIMIT_SWITCHES, IDENT_EXT_LEAKAGE_SENSOR, IDENT LEAKAGE DETECTION, IDENT_EXT_POS_SENSOR)
AO TRD: SET_FAIL_SAFE_POS (114)
Storage class S; read/write capability r/w
Set fail-safe position
<ul style="list-style-type: none"> • NOT ACTIVE • SET FAIL-SAFE POSITION • CLEAR FAIL-SAFE POSITION
Note: The fail-safe position is indicated on the positioner display by a blinking 'S'.

AO TRD:	SIGNAL_ACTION (34) Storage class S; read/write capability r/w; supported modes O/M/A Direction of action of the set point w in relation to the travel/angle x → Code 7
AO TRD:	SKR (192) Storage class D; read capability r Tests > Static characteristic: display <ul style="list-style-type: none"> • STAT_KENNL_R_TEST_INFO · Current status of the test • STAT_KENNL_R_STEP_HEIGHT · Step height • STAT_KENNL_R_MIN_DEAD_BAND · Smallest dead band measured • STAT_KENNL_R_AVERAGE_DEAD_BAND · Average dead band measured • STAT_KENNL_R_MAX_DEAD_BAND · Largest dead band measured • STAT_KENNL_R_PROGRESS_FLAG · Current progress of the test
AO TRD:	SKW (193) Storage class S; read/write capability r/w Tests > Static characteristic: enter values <ul style="list-style-type: none"> • STAT_KENNL_W_START_VALUE · Start value of valve position x • STAT_KENNL_W_END_VALUE · End value of valve position x • STAT_KENNL_W_DELAY_TIME · Delay time after step • STAT_KENNL_W_TURN_BACK_VALUES · Number of measured values recorded before changing the testing direction
AO TRD:	SSAF (133) Storage class D; read/write capability r/w Execute/end various EXPERTplus tests <ul style="list-style-type: none"> • Reference tests (d1, d2) • Data logger • Tests (d1 to d6 and d9)
AO TRD:	STOP_HI (27) Storage class S; read/write capability r/w; supported modes O/M/A Travel/angle upper limit → Code 11 <ul style="list-style-type: none"> • 50 ... 120 %, [100 %] <p>Note: The characteristic is not adapted. The tight-closing function has priority.</p>

<p>AO TRD: STOP_LO (28) Storage class S; read/write capability r/w; supported modes O/M/A Travel/angle lower limit → Code 10 • 0.0 ... 49.9 %, [0.0 %] Note: The characteristic is not adapted. The tight-closing function has priority.</p>
<p>AO TRD: STOP_HI_POS_ON (130) Storage class S; read/write capability r/w; supported modes O/M/A Enable travel/angle upper limit → Code 11 • [ON] • OFF</p>
<p>AO TRD: STOP_LO_POS_ON (129) Storage class S; read/write capability r/w; supported modes O/M/A Enable travel/angle lower limit → Code 10 • ON • [OFF]</p>
<p>AO TRD: STRATEGY (3) Storage class S; read/write capability r/w Permits strategic grouping and thus faster processing of blocks • [0] Blocks are grouped by entering the same number in the STRATEGY parameter of each block. Note: These data are neither checked nor processed by the AO Transducer Block.</p>
<p>AO TRD: STROKE_TIME_CLOSED (71) Storage class S; read capability r Minimum transit time CLOSED → Code 41 Time [s] required by the system (positioner, actuator and valve) to move through the rated travel/angle in the direction to close the valve (0 % position) The value is measured during initialization.</p>
<p>AO TRD: STROKE_TIME_CLOS_LIM (92) Storage class S; read/write capability r/w Required transit time CLOSED → Code 22 Time required to move through the operating range when the valve closes.</p>

AO TRD: STROKE_TIME_OPEN (72)

Storage class S; read capability r

Minimum transit time OPEN → Code 40

Time [s] required by the system (positioner, actuator and valve) to move through the rated travel/angle in the direction to open the valve (100 % position)

The value is measured during initialization.

AO TRD: STROKE_TIME_OPEN_LIM (93)

Storage class S; read/write capability r/w

Required transit time OPEN → Code 21

Time required to move through the operating range when the valve opens.

AO TRD: STR_DEVICE_CHARACTERISTIC (113)

Storage class S; read/write capability r/w; supported modes O/M/A

Specific positioner data

- MODEL · Actuator type
- ATTACHMENT (actuator)
- BOOSTER · Volume booster (actuator)
- ACTUATOR_SIZE · Effective actuator area
- SIGNAL_PRESSURE_LOWER_VALUE (actuator)
- SIGNAL_PRESSURE_UPPER_VALUE (actuator)
- SUPPLY_PRESSURE
- FLOW_DIRECTION1 (valve)
- STUFFING_BOX · Packing (valve)
- CYCLE_CNTR_LIM1 SEALING_EDGE · Leakage class (valve)
- PRESSURE_BALANCING (valve)
- FLOW_CHARACTERISTIC (valve)
- NOM_DIAMETER · Size standard (valve)
- NOM_DIAMETER_DN (valve)
- KVS_VALUE · KVS coefficient (valve)
- KVS_UNIT
- SEAT_DIAM_VALVE · Seat bore diameter (valve)
- LENGTH_UNITS
- PRESSURE_UNIT

AO TRD: ST_REV (1)
Storage class S; read capability r
Static revision number
Note: The revision number is incremented with each change of a static parameter in the block.
AO TRD: SUB_MOD_INIT (118)
Storage class D; read capability r
Indicates whether the initialization was performed in SUB mode (substitute calibration).
AO TRD: TAG_DESC (2)
Storage class S; read/write capability r/w
User-specific text for unique identification and assignment of the block
• Max. 32 characters, [no text]
AO TRD: THRESHOLD_END_POS_RECORDING (207)
Storage class D; read/write capability r/w
Statistical information > Trend of travel end position
Recording threshold
AO TRD: TRANSDUCER_DIRECTORY (9) · This parameter is not supported.
AO TRD: TRANSDUCER_STATE (102)
Storage class D; read capability r
State of the Transducer Block → Code 48 t2
11 See operating mode
12 Solenoid valve active · Forced venting active
13 Lower travel limit active
14 Upper travel limit active
15 End position < active · Tight-closing of the valve
16 End position > active · Maximum open position of the valve
17 Fail-safe position active
18 Normal operation
AO TRD: TRANSDUCER_TYPE (10)
Storage class D; read capability r
Indicates the type of transducer. "Standard Advanced Positioner Valve" in this case.

AO TRD:	TRANSDUCER_TYPE_VER (11) Storage class D; read capability r Transducer Block for positioner according to Specification FF-90
AO TRD:	TRANSM_PIN_POS (115) Storage class S; read/write capability r/w Pin position → Code 4
AO TRD:	TRAVEL_ACCUM (29) Storage class D; read capability r Total valve travel: totaled double valve travel → Code 23
AO TRD:	TRAVEL_ACCUM_DEADBAND (73) · This parameter is not supported.
AO TRD:	TRAVEL_ACCUM_LIM (94) · This parameter is not supported.
AO TRD:	TRAVEL_ACCUM_UNITS (95) · This parameter is not supported.
AO TRD:	TRAVEL_UNITS (30) Storage class S; read/write capability r/w; supported modes O/M/A Unit of valve travel according to Table TN-016 • [%] or [°], in the event that the positioner is not initialized
AO TRD:	TRIP_TIMEOUT (74) · This parameter is not supported.
AO TRD:	TV_STEP (128) Storage class S; read/write capability r/w Derivative-action time TV (step) → Code 18 Note: This parameter can only be read over FOUNDATION fieldbus. The value is recorded during initialization.
AO TRD:	UPDATE_EVT (7) Storage class D; read/write capability r/w Indicates whether static data have been changed, including date and time stamp.
AO TRD:	VALVE_MAN_ID (42) Storage class S; read/write capability r/w; supported modes O/M/A Manufacturer of the valve on which the positioner is mounted.

Parameter lists

AO TRD: VALVE_MODEL_NUM (43)
Storage class S; read/write capability r/w; supported modes O/M/A
Model of the valve on which the positioner is mounted.
AO TRD: VALVE_SN (44)
Storage class S; read/write capability r/w; supported modes O/M/A
Serial number of the valve on which the positioner is mounted.
AO TRD: VALVE_TYPE (45)
Storage class S; read/write capability r/w; supported modes O/M/A
Type of valve
-/- · Undefined (treated as a globe valve)
• [LINEAR] · (control valves with straight moving plug, e.g. globe valves)
• ROTARY · (control valves with rotating closure members, e.g. part-turn, etc.)
• OTHER · (treated as a globe valve)
Note: The Type 3730-5 differentiates merely between linear and rotary valves, "UNINITIALIZED" and "OTHER" are treated as globe valves
AO TRD: VST_COMMAND (56)
Storage class D; read/write capability r/w; supported modes M/A
Start/abort the partial stroke test (PST)/full stroke test (FST)
AO TRD: VST_DETAILED_RESULT (60) · This parameter is not supported.
AO TRD: VST_MODE (57)
Storage class S; read/write capability r/w; supported modes O/M/A
VST (Valve Stroke Test) to be performed
• Deactivated
• [PST (partial stroke test)]
• FST (full stroke test)
AO TRD: VST_PAUSE (58)
Storage class S; read/write capability r/w; supported modes O/M/A
Waiting time after the first step until the second step starts
• 0.1 ... 240.0 s, [2.0 s]
AO TRD: VST_RESULT (59)
Storage class N; read capability r
Indicates that the result of the last PST/FST (successful/not successful)

AO TRD:	WORKING_POS (19) Storage class D; read capability r Actual valve position in %
AO TRD:	WORKING_POS_D (51) Storage class D; read capability r Actual discrete valve position
AO TRD:	WORKING_SP (20) Storage class N; read capability r Set point after scaling, characterization and the end position function Corresponds to the set point of the control algorithm for the AO Function Block (Control valve mode).
AO TRD:	WORKING_SP_D (52) Storage class N; read capability r Discrete set point after taking the direction of action into account Corresponds to the set point of the control algorithm for the DO Function Block (Open/Close mode).
AO TRD:	XD_CAL_DATE (47) Storage class S; read/write capability r/w; supported modes O/M/A Time of last calibration
AO TRD:	XD_CAL_LOC (46) Storage class S; read/write capability r/w; supported modes O/M/A Place of last calibration
AO TRD:	XD_CAL_WHO (48) Storage class S; read/write capability r/w; supported modes O/M/A Person who performed last calibration

AO TRD: XD_COMMAND (36)

Storage class D; read/write capability r/w

Parameters to start device-specific procedures

- No test, normal operation
- Start with default values
- Start Initialization
- Abort Initialization
- Start Zero Point adjustment
- Abort Zero Point adjustment
- Search device

AO TRD: XD_COMMAND_FLAGS (75) · This parameter is not supported.

AO TRD: XD_COMMAND_STATE (37)

Storage class D; read capability r

Initialization status

AO TRD: XD_ERROR (12)

Storage class D; read capability r

Error listed in the AO Transducer Block

- NONE (0) · No error
- UNSPECIFIED ERROR · · Unspecified (device not initialized, initialization or zero calibration in progress or total valve travel exceeded)
- GENERAL ERROR · General device error
- CALIBRATION ERROR · Zero point, internal control loop or initialization error, reference test canceled → Code 81
- CONFIGURATION ERROR · Parameter or characteristic faulty
- ELECTRONICS FAILURE · i/p converter (Code 64), hardware (Code 65), bus connection
- MECHANICAL FAILURE
- DATA INTEGRITY ERROR · Check sum error
- ALGORITHM ERROR · Dynamic values outside range

AO TRD: XD_ERROR_EXT (103)

Storage class D; read capability r

Extended errors listed in the AO Transducer Block

1 xd_error_ext_1

- Device not initialized
- Int. solenoid valve active
- Tot.valve travel limit exc.
- Control loop → Code 57
- Zero point → Code 58
- Autocorrection → Code 59
- Fatal error → Code 60
- Extended diagnostics → Code 79
- $x >$ range → Code 50
- $\Delta x <$ range → Code 51
- Attachment → Code 52
- Init. time exceeded → Code 53
- Init./int. solenoid valve → Code 54
- Travel time too short → Code 55
- Pin position/safety switch → Code 56
- Test or calibration running

2 xd_error_ext_2

- x-signal → Code 62
- i/p-converter → Code 64
- Hardware → Code 65
- Control parameter → Code 68
- Poti parameter → Code 69
- Adjustment parameter → Code 70
- General parameter → Code 71
- Internal device error 1 → Code 73
- No emergency mode → Code 76
- Program load error → Code 77
- Options parameter → Code 78
- Info parameter → Code 75
- Data memory → Code 66
- Control calculation → Code 67
- Reference test aborted → Code 81

- 3 xd_error_ext_3
 - Reset comm. controller
 - Attachment unit disturbed
 - Bin 2 deactivated
 - Reset appl. controller
 - FF parameter
 - Mode unequal AUTO
 - Temperature exceeding
- 14 Air Supply
- 15 Actuator Spring
- 16 Shifting Working Range
- 17 Friction
- 18 Leakage Pneumatic
- 19 Limit Working Range
- 20 Inner Leakage
- 21 External Leakage
- 22 Observing End Position
- 23 Connection Positioner Valve
- 24 Working Range
- 25 Temperature Error
- 26 PST/FST Status
- 27 Open Close Status

AO TRD: XD_FSTATE_OPT (32)

Storage class S; read/write capability r/w; supported modes O/M/A

Action on fault detection in AO TRD

- [Hold last value]
- Fail-safe position
- Fault state value (XD_FSTATE_VAL)

AO TRD: XD_FSTATE_VAL (31)

Storage class S; read/write capability r/w; supported modes O/M/A

Fault state value to which the valve moves when the AO Transducer Block is in the O/S mode and the action on fault detection has been selected in the XD_OOS_OPTS parameter.

- 0 ... 100 %, [0 %]

AO TRD:	XD_FSTATE_VAL_D (53) Storage class S; read/write capability r/w; supported modes O/M/A Discrete fault state value to which the valve moves when the AO Transducer Block is in the O/S mode and the action on fault detection has been selected in the XD_OOS_OPTS parameter. • [0], 10 - 0 %1 - 100 %
AO TRD:	XD_OOS_OPT (54) Storage class S; read/write capability r/w; supported modes O/M/A Action when the AO Transducer Block is in the O/S mode • [Hold last value] • Fail-safe position • Fault state value (XD_FSTATE_VAL)
AO TRD:	Y_HYST_MIN_TIME_DISTANCE (160) Storage class S; read/write capability r/w; supported modes O/M/A Statistical information > Drive signal diagram > Hysteresis Time until test (d5) is repeated • 0 to 24 h, [1 h]
AO TRD:	Y_HYST_TESTINFO (162) Storage class D; read capability r Statistical information > Drive signal diagram hysteresis (d5 test): test status
AO TRD:	Y_HYST_TEST_INFO (186) Storage class D; read capability r Tests > Drive signal diagram hysteresis (d2 test): test status
AO TRD:	Y_HYST_TEST_PROGRESS (187) Storage class D; read capability r Tests > Drive signal diagram hysteresis (d2 test): progress of test in %
AO TRD:	Y_HYST_TEST_TIME_STAMP (185) Storage class D; read capability r Tests > Drive signal diagram hysteresis (d2 test): time stamp for reference value recording
AO TRD:	Y_HYST_TOLERANCE_BAND (161) Storage class D; read/write capability r/w; supported modes O/M/A Statistical information > Drive signal diagram > Hysteresis Tolerance band of test (d5) (the test is canceled when the value leaves the tolerance band)

Parameter lists

AO TRD: Y_STAT_TEST_INFO (179)
Storage class D; read capability r
Tests > Drive signal diagram steady (d1 test)
Current test status
AO TRD: Y_STAT_TEST_PROGRESS (180)
Storage class D; read capability r
Tests > Drive signal diagram steady (d1 test)
Current test progress
AO TRD: Y_STAT_TEST_TIME_STAMP (178)
Storage class D; read capability r
Tests > Drive signal diagram steady (d1 test)
Time stamp for reference value recording

Index and parameter assignment: AO TRD

Index	Parameters
38	ACT_FAIL_ACTION
39	ACT_MAN_ID
40	ACT_MODEL_NUM
41	ACT_SN
101	ALARM_OPTION
4	ALERT_KEY
147	ANALYSIS_OPEN_CLOSE
144	APPLICATION_TYPE_OC_CONTROL
175	AUTOMATIC_TEST_STATUS
111	BINARY_INPUT_2
124	BLOCKING_POSITION
8	BLOCK_ALM
6	BLOCK_ERR
91	CHARACTERIZATION
61	CLOSED_POS_DEADBAND
62	CLOSED_POS_SHIFT
121	CLOSING_DIRECTION
110	CONFIG_BINARY_INPUT_2

Index	Parameters
138	COUNTER_INIT_START
63	CUSTOM_CURVE_DESCRIPTION
65	CUSTOM_CURVE_XY_FLOAT
33	CYCLE_CNTR
76	CYCLE_CNTR_LIM
173	DEPTXE
174	DEPTXR
21	DEVIATION_DEADBAND
105	DEVIATION_MAX
104	DEVIATION_MIN
22	DEVIATION_TIME
23	DEVIATION_VALUE
120	DEVICE_INIT_STATE
121	DEVICE_STATUS_INIT
132	DIAG_LEVEL
176	DIAG_REFLAUF_INFO
142	DIAG_RESET_AFTER_TIME
143	DIAG_RESET_AFTER_TIMEOUT

Index	Parameters
194	DSKV1
195	DSKV2
196	DSKV3
197	DSKV4
198	DSKW1
199	DSKW2
200	DSKW3
201	DSKW4
191	DSXHTW
182	DSXSTR
184	DSXSTW
189	DSYHTR
190	DSYHTW
157	DSYSK
156	DSYSL
158	DSYSS
181	DSYSTR
183	DSYSTW
159	DVPSS
136	EHM
168	END_POS_TREND_REF_DRIVE_SIG_REF
167	END_POS_TREND_REF_TIME_REF
166	END_POS_TREND_REF_VALUES_REF
171	EPTRDS
170	EPTRT
169	EPTRV
139	EVENT_LOGGING_1
140	EVENT_LOGGING_2
18	FINAL_POSITION_VALUE
50	FINAL_POSITION_VALUE_D
131	FINAL_POSITION_VALUE_LIMITS
14	FINAL_VALUE

Index	Parameters
16	FINAL_VALUE_CUTOFF_HI
123	FINAL_VALUE_CUTOFF_HI_ON
17	FINAL_VALUE_CUTOFF_LO
122	FINAL_VALUE_CUTOFF_LO_ON
49	FINAL_VALUE_D
15	FINAL_VALUE_RANGE
68	FRICTION
265	FRICTION_LIMITS
67	FRICTION_UNITS
86	FST_BREAKOUT_TIME
87	FST_BREAKOUT_TIMEOUT
90	FST_COMPLETION_TIMEOUT
257	FST_DIAGR_E1
258	FST_DIAGR_E2
259	FST_DIAGR_E3
260	FST_DIAGR_E4
245	FST_DIAGR_TIME1
246	FST_DIAGR_TIME2
247	FST_DIAGR_TIME3
248	FST_DIAGR_TIME4
253	FST_DIAGR_W1
254	FST_DIAGR_W2
255	FST_DIAGR_W3
256	FST_DIAGR_W4
249	FST_DIAGR_X1
250	FST_DIAGR_X2
251	FST_DIAGR_X3
252	FST_DIAGR_X4
261	FST_DIAGR_Y1
262	FST_DIAGR_Y2
263	FST_DIAGR_Y3
264	FST_DIAGR_Y4

Parameter lists

Index	Parameters
238	FST_DISPLAY
239	FST_MEAS_DATA1
240	FST_MEAS_DATA2
241	FST_MEAS_DATA3
88	FST_RAMP_RATE
237	FST_SETTINGS
89	FST_STRK_TRAV_TIMEOUT
235	FST_TEST_INFO
274	FST_TEST_STAT1
275	FST_TEST_STAT2
276	FST_TEST_STAT3
135	HIST
150	HISTOGR_X_SCAN_RATE
149	HISTOGR_X_SHORT
148	HXL
69	HYSTERESIS
163	HYST_SHORT_DIFF_Y
164	HYST_VALVE_POS
108	IDENT_OPTIONS
116	INIT_METHOD
117	INIT_WITH_REF_TEST
96	INTERNAL_TEMP
98	INTERNAL_TEMP_MAX
97	INTERNAL_TEMP_MIN
99	INTERNAL_TEMP_UNITS
127	KP_STEP
145	LIMIT_VALUE_TIME_ANALYSIS
146	LIMIT_VALUE_TRAVEL_ANALYSIS
106	LOGGING_MGV
306	LS_ALARM_INFORMATION
270	LS_ALARM_LIMIT_1
271	LS_ALARM_LIMIT_2

Index	Parameters
272	LS_ALARM_LIMIT_3
304	LS_ALARM_RELEASE
266	LS_LEAKAGE_LEVEL
268	LS_SELECT_ALARM_LIMITS
273	LS_TEST_INFORMATION
107	MIN_CLEARANCE_NEW_LOGGING_MGV
5	MODE_BLK
137	NO_OF_ZERO_POINT_ADJ
119	OPTI_SUB_INIT
207	PCC
209	PMD1
210	PMD2
211	PMD3
112	POSITIONER_MODEL
24	POS_ALERT_HI
25	POS_ALERT_LO
70	POS_DEADBAND
55	POS_FEATURES
125	PRESSURE_LIMIT
141	PROTOKOLL_BSZ_START
203	PST_AUTOSTART_READ
77	PST_BREAKOUT_TIME
78	PST_BREAKOUT_TIMEOUT
85	PST_COMPLETION_TIMEOUT
227	PST_DIAGR_E1
228	PST_DIAGR_E2
229	PST_DIAGR_E3
230	PST_DIAGR_E4
215	PST_DIAGR_TIME1
216	PST_DIAGR_TIME2
217	PST_DIAGR_TIME3
218	PST_DIAGR_TIME4

Index	Parameters
223	PST_DIAGR_W1
224	PST_DIAGR_W2
225	PST_DIAGR_W3
226	PST_DIAGR_W4
219	PST_DIAGR_X1
220	PST_DIAGR_X2
221	PST_DIAGR_X3
222	PST_DIAGR_X4
231	PST_DIAGR_Y1
232	PST_DIAGR_Y2
233	PST_DIAGR_Y3
234	PST_DIAGR_Y4
208	PST_DISPLAY
79	PST_INITIAL_START_TIME
80	PST_INTERVAL
81	PST_OPTIONS
82	PST_RAMP_RATE
206	PST_SETTINGS
83	PST_STRK_TRAV
84	PST_STRK_TRAV_TIMEOUT
202	PST_TESTMODE_TARGET
204	PST_TEST_INFO
212	PST_TEST_STAT1
213	PST_TEST_STAT2
214	PST_TEST_STAT3
26	RATED_TRAVEL
35	READBACK_SELECT
177	REFLAUF_VOLLST
134	RESET_STATUS_MESSAGE_DIAG
126	SELECT_EMERGENCY_MODE
109	SELO
114	SET_FAIL_SAFE_POS

Index	Parameters
34	SIGNAL_ACTION
192	SKR
193	SKW
133	SSAF
27	STOP_HI
28	STOP_LO
129	STOP_LO_POS_ON
3	STRATEGY
71	STROKE_TIME_CLOSED
92	STROKE_TIME_CLOS_LIM
72	STROKE_TIME_OPEN
93	STROKE_TIME_OPEN_LIM
113	STR_DEVICE_CHARACTERISTIC
1	ST_REV
118	SUB_MOD_INIT
2	TAG_DESC
207	THRESHOLD_END_POS_RECORDING
9	TRANSDUCER_DIRECTORY
102	TRANSDUCER_STATE
10	TRANSDUCER_TYPE
11	TRANSDUCER_TYPE_VER
115	TRANSM_PIN_POS
29	TRAVEL_ACCUM
73	TRAVEL_ACCUM_DEADBAND
94	TRAVEL_ACCUM_LIM
95	TRAVEL_ACCUM_UNITS
30	TRAVEL_UNITS
74	TRIP_TIMEOUT
128	TV_STEP
7	UPDATE_EVT
42	VALVE_MAN_ID
43	VALVE_MODEL_NUM

Parameter lists

Index	Parameters
44	VALVE_SN
45	VALVE_TYPE
56	VST_COMMAND
60	VST_DETAILED_RESULT
57	VST_MODE
58	VST_PAUSE
59	VST_RESULT
19	WORKING_POS
51	WORKING_POS_D
20	WORKING_SP
52	WORKING_SP_D
47	XD_CAL_DATE
46	XD_CAL_LOC
48	XD_CAL_WHO
36	XD_COMMAND
75	XD_COMMAND_FLAGS

Index	Parameters
37	XD_COMMAND_STATE
12	XD_ERROR
103	XD_ERROR_EXT
32	XD_FSTATE_OPT
31	XD_FSTATE_VAL
53	XD_FSTATE_VAL_D
54	XD_OOS_OPT
160	Y_HYST_MIN_TIME_DISTANCE
162	Y_HYST_TESTINFO
186	Y_HYST_TEST_INFO
187	Y_HYST_TEST_PROGRESS
185	Y_HYST_TEST_TIME_STAMP
161	Y_HYST_TOLERANCE_BAND
179	Y_STAT_TEST_INFO
180	Y_STAT_TEST_PROGRESS
178	Y_STAT_TEST_TIME_STAMP

9.2 Analog Output Function Block (AO FB)

AO FB:	<p>ALERT_KEY (4) Storage class S; read/write capability r/w; supported modes O/M/A</p> <p>ID number of the plant section</p> <ul style="list-style-type: none"> • 1 to 255, [0] <p>May be used by the fieldbus host system to sort alarms and events.</p> <p>Note: '0' is not permissible and will be rejected when transferring data to the device (error alarm).</p>
AO FB:	<p>BKCAL_OUT (25) Storage class D; read capability r</p> <p>Analog output value for upstream block (value and status)</p> <p>BKCAL_OUT is passed on to the BKCAL_IN parameter of the upstream function block for cascade control. It prevents integral windup of the controller and thus ensures bumpless switching between operating modes.</p>
AO FB:	<p>BLOCK_ALM (30) Storage class D; read capability r</p> <p>Current block state with details on all configuration, hardware or system problems in the block including date and time stamp.</p>
AO FB:	<p>BLOCK_ERR (6) Storage class D; read capability r</p> <p>Active block error → Code 48 A8</p> <ul style="list-style-type: none"> • OUT OF SERVICE • CONFIGURATION_ERROR • INPUT FAILURE PV · Position feedback has bad status e.g. because the Transducer Block is in the O/S mode. • OUTPUT FAILURE · OUT value cannot be issued, e.g. because the Transducer Block is not initialized or in the LO mode.
AO FB:	<p>CAS_IN (17) Storage class N; read/write capability r/w; supported modes ALL</p> <p>Analog set point, adopted from an upstream function block (value and status) → Code 48 A2/A3</p>

AO FB:	<p>CHANNEL (22)</p> <p>Storage class S; read/write capability r/w; supported modes O</p> <p>Assignment of the output of AO Function Block and the logical hardware channels (Transducer Block).</p> <ul style="list-style-type: none"> • [3] <p>Note: Set CHANNEL to 3 to start up the AO Function Block. This allows it to be assigned to AO TRD.</p>
AO FB:	<p>FSTATE_TIME (23)</p> <p>Storage class S; read/write capability r/w; supported modes ALL</p> <p>Fault state time [s]</p> <p>Time between an error in the set point valid for the AO Function Block in the current operating mode is detected and failure action is triggered.</p> <ul style="list-style-type: none"> • [0] <p>Note: Failure action is triggered if the error persists after this time has elapsed. The fault state of the AO Function Block is determined in the IO_OPTS parameter of this block.</p>
AO FB:	<p>FSTATE_VAL (24)</p> <p>Storage class S; read/write capability r/w; supported modes ALL</p> <p>Fault state value for the AO Function Block when failure action is triggered.</p> <ul style="list-style-type: none"> • Value and range from PV_SCALE $\pm 10\%$, [0] <p>Note: The value is used if the FAULT STATE TO VALUE option is selected in the IO_OPTS parameter.</p>
AO FB:	<p>GRANT_DENY (13) · This parameter is not supported.</p>
AO FB:	<p>IO_OPTS (14)</p> <p>Storage class S; read/write capability r/w; supported modes O</p> <p>Selects the input/output behavior of the AO Function Block.</p> <ul style="list-style-type: none"> • SP-PV TRACK IN MAN · SP tracks PV in MAN mode (Actual Mode) • SP-PV TRACK IN LO · SP tracks PV in LO mode (Actual Mode) • SP TRACK RETAINED TARGET · SP tracks RCAS_IN or CAS_IN depending on the preset target mode in LO or MAN mode (actual mode). This option has priority over SP-PV TRACK IN MAN/LO. • INCREASE TO CLOSE · Inverts the output value to the Transducer Block (corresponds to the direction of action)

- **FAULT STATE TO VALUE** · FSTATE_VAL is used as the set point when the failure action is triggered (see FSTATE_VAL, FSTATE_TIME)
- **USE FAULT STATE VALUE ON RESTART** · FSTATE_VAL is used as the set point upon restarting until a valid value has been entered.
- **TARGET TO MAN IF FAULT STATE ACTIVATED** · When failure action is triggered, the target mode is set to MAN and the original target mode is lost. The block remains in MAN mode after failure action has been left until the user sets it to the desired operating mode.
- **USE PV FOR BKCAL_OUT** · The PV process value is fed back at BKCAL_OUT instead of the working process value. If the OUT READBACK option is activated in the FEATURES_SEL Resource Block parameter, BKCAL_OUT feeds back the current valve position.

AO FB: MODE_BLK (5)

Storage class N; read/write capability r/w; supported modes ALL

Operating mode

– Target Mode → Code 48 A0

– Actual Mode (read only) → Code 48 A1

– Permitted Mode

– Normal Mode (read only)

- **O/S** · The AO Function Block is not executed. The last value or the value determined during an active fault processing is issued at the OUT parameter.
- **MAN** · The output value of the AO Function block can be entered manually by the operator over the OUT parameter.
- **AUTO** · The set point entered by the operator is used over the SP parameter upon execution of the AO Function Block.
- **CAS** · The AO Function Block receives the set point directly from an upstream function block over the CAS_IN parameter for internal calculation of the out value. The AO Function Block is implemented.
- **RCAS** · The AO Function Block receives the set point directly from the fieldbus host system over the RCAS_IN parameter for internal calculation of the out value. The AO Function Block is implemented.

AO FB: OUT (9)

Storage class N; read/write capability r/w; supported modes M/O

Out value of the AO Function Block (value, limit and status) → Code 48 A6/7

- Range of OUT_SCALE $\pm 10\%$; unit of the XD_SCALE parameter group

Note: The OUT value can be entered manually when the MAN mode is selected in the MODE_BLK parameter.

Parameter lists

AO FB:	PV (7) Storage class D; read capability r Process variable of the function block (value and status) <ul style="list-style-type: none">• Unit from the XD_SCALE parameter group. Note: If the OUT READBACK option is activated in the FEATURES_SEL resource block parameter, PV contains the current valve position (corresponding to FINAL_POSITION_VALUE).
AO FB:	PV_SCALE (11) Storage class S; read/write capability r/w; supported modes O Range of the process variable (PV) (start, end, unit and decimal point) <ul style="list-style-type: none">• 0 to 100 %
AO FB:	RCAS_IN (26) Storage class N; read/write capability r/w; supported modes ALL Analog set point for internal calculation of the out value (value and status) The RCAS_IN value is provided by the fieldbus host system. Note: This parameter is only active in RCAS mode.
AO FB:	RCAS_OUT (28) Storage class D; read capability r Analog set point after applying the ramp function (value and status) The RCAS_OUT value is provided to the fieldbus host system to perform back-calculations in case of control mode changes or limited signals. Note: This parameter is only active in RCAS mode.
AO FB:	READBACK (16) Storage class D; read capability r Current valve position determined from the FINAL_POSITION_VALUE of the associated Transducer Block <ul style="list-style-type: none">• Unit from the XD_SCALE parameter group.

AO FB: SHED_OPT (27)

Storage class S; read/write capability r/w; supported modes ALL

Behavior upon exceeding the monitoring time (see SHED_RCAS in the Resource Block)

Monitoring of the connection between fieldbus host system and AO Function Block in RCAS mode. When the monitoring time has elapsed, AO Function Block switches from the RCAS mode to the selected operating mode.

The action to be taken after the fault state ends is also determined.

- [UNINITIALIZED]
- NORMAL SHED_NORMAL RETURN · On failure of remote connection, change to next possible mode until RCAS mode is restored.
- NORMAL SHED_NO RETURN · On failure of remote connection, change to next possible mode. The block remains in this mode.
- SHED TO AUTO_NORMAL RETURN · On failure of remote connection, change to AUTO mode until RCAS mode is restored.
- SHED TO AUTO_NO RETURN · On failure of remote connection, change to AUTO mode. No attempt is made to restore the mode and the block remains in AUTO mode.
- SHED TO MANUAL_NORMAL RETURN · On failure of remote connection, change to MAN mode until RCAS mode is restored.
- SHED TO MANUAL_NO RETURN · On failure of remote connection, change to MAN mode. No attempt is made to restore the mode and the block remains in MAN mode.
- SHED TO RETAINED_TARGET_NORMAL RETURN · On failure of remote connection, the block attempts to attain the retained target mode until RCAS mode is restored.
- SHED TO RETAINED_TARGET_NO RETURN · On failure of remote connection, the block sets the target mode to the retained target mode.

Note: This parameter is only active in RCAS mode in the AO Function Block.

If the value is set to UNINITIALIZED, the AO Function Block cannot be placed in the RCAS mode.

AO FB: SIMULATE (10)

Storage class D; read/write capability r/w; supported modes ALL

Simulation of the process variable PV of the block (value and status) → Code 48 F3

Note: During simulation, OUT is not transmitted to the Transducer Block; the block retains the last valid value received before simulation was activated.

The simulation can only be activated when SIMULATE ACTIVE is set in the BLOCK_ERR parameter of the Resource Block.

AO FB:	SP (8) Storage class N; read/write capability r/w; supported modes O/M/A Set point w in AUTO mode → Code 48 A4/5 • Value and range from PV_SCALE ±10 %; unit of PV_SCALE
AO FB:	SP_HI_LIM (20) Storage class S; read/write capability r/w; supported modes ALL Upper set point limit • Value and range from PV_SCALE ±10 %, [100 %] Note: Adapt this value accordingly if the end-of-scale value in the PV_SCALE parameter is changed.
AO FB:	SP_LO_LIM (21) Storage class S; read/write capability r/w; supported modes ALL Lower set point limit • Value and range from PV_SCALE ±10 %, [0 %] Note: Adapt this value accordingly if the end-of-scale value in the PV_SCALE parameter is changed.
AO FB:	SP_RATE_DN (18) Storage class S; read/write capability r/w; supported modes ALL Set point downward rate limit in AUTO mode • [3402823466 × 10 ³⁸] Note: If '0' is entered, the set point is used. The speed limitation for output blocks is active in AUTO and CAS modes.
AO FB:	SP_RATE_UP (19) Storage class S; read/write capability r/w; supported modes ALL Set point upward rate limit in AUTO mode • [3402823466 × 10 ³⁸] Note: If '0' is entered, the set point is used. The speed limitation for output blocks is active in AUTO and CAS modes.
AO FB:	ST_REV (1) Storage class N; read capability r Static revision number (AO Function Block) Note: The revision number is incremented with each change of a static parameter in the block.

AO FB:	<p>STATUS_OPTS (15) Storage class S; read/write capability r/w; supported modes O</p> <p>Status options to determine status handling and processing</p> <ul style="list-style-type: none"> • [UNINITIALIZED] • PROPAGATE FAULT BACKWARD · Status of the Transducer Block is passed on to the upstream block over the status of BKCAL_OUT.
AO FB:	<p>STRATEGY (3) Storage class S; read/write capability r/w; supported modes ALL</p> <p>Permits strategic grouping and thus faster processing of blocks</p> <ul style="list-style-type: none"> • [0] <p>Blocks are grouped by entering the same number in the STRATEGY parameter of each block.</p> <p>Note: These data are neither checked nor processed by the AO Function Block.</p>
AO FB:	<p>TAG_DESC (2) Storage class S; read/write capability r/w; supported modes ALL</p> <p>User-specific text for unique identification and assignment of the block</p> <ul style="list-style-type: none"> • Max. 32 characters, [no text]
AO FB:	<p>UPDATE_EVT (29) Storage class D; read capability r</p> <p>Indicates whether static block data have been changed, including date and time stamp</p>
AO FB:	<p>XD_SCALE (12) Storage class S; read/write capability r/w; supported modes O</p> <p>Range of the OUT value (start, end, unit and decimal point)</p> <ul style="list-style-type: none"> • 0.0 to 100.0 %; specified in [%], [mm] or [degrees] <p>Note: When [%] is used, the OUT value is based on the scale of 100 %. In case of [mm] (with globe valves) or [degrees] (with rotary valves), the OUT value corresponds to the value set in the RATED_TRAVEL parameter in the Transducer Block which is scaled as 100 %.</p>

Index and parameter assignment: AO Function Block

Index	Parameters
1	ST_REV
2	TAG_DESC
3	STRATEGY
4	ALERT_KEY
5	MODE_BLK
6	BLOCK_ERR
7	PV
8	SP
9	OUT
10	SIMULATE
11	PV_SCALE
12	XD_SCALE
13	GRANT_DENY
14	IO_OPTS
15	STATUS_OPTS

Index	Parameters
16	READBACK
17	CAS_IN
18	SP_RATE_DN
19	SP_RATE_UP
20	SP_HI_LIM
21	SP_LO_LIM
22	CHANNEL
23	FSTATE_TIME
24	FSTATE_VAL
25	BKCAL_OUT
26	RCAS_IN
27	SHED_OPT
28	RCAS_OUT
29	UPDATE_EVT
30	BLOCK_ALM

9.3 Analog Input Function Block (AI FB)

AI FB:	<p>ACK_OPTION (23) Read/write capability r/w; supported modes ALL</p> <p>Automatic alarm acknowledgement (AI Function Block)</p> <ul style="list-style-type: none"> • [UNDEFINED] · No selection • HI_HI_ALM · High-high alarm • HI_ALM · High pre-alarm • LO_LO_ALM · Low-low alarm • LO_ALM · Low pre-alarm • DV_HI_ALM · Limit alarm for upper set point deviation • DV_LO_ALM · Limit alarm for lower set point deviation • BLOCK_ALM · Block alarm <p>Note: The alarm is broadcast to the fieldbus host system, but not acknowledged by it.</p>
AI FB:	<p>ALARM_HYS (24) Read/write capability r/w; supported modes ALL</p> <p>Hysteresis for the low and high alarm limits</p> <ul style="list-style-type: none"> • 0 to 50 %, [0.5 %] <p>The alarm conditions remain active as long as the measured value remains within the hysteresis. The hysteresis value has an effect on the following alarm limits of the AI Function Block:</p> <p>HI_HI_LIM; HI_LIM; LO_LO_LIM; LO_LIM; DV_HI_LIM; DV_LO_LIM</p> <p>Note: The hysteresis value is a percentage of the PV_SCALE range in the AI Function Block.</p>
AI FB:	<p>ALARM_SUM (22) Read capability r</p> <p>Current status of process alarms in the AI Function Block</p> <ul style="list-style-type: none"> • HI_HI_ALM · Violation of the high-high alarm • HI_ALM · Violation of the high pre-alarm • LO_LO_ALM · Violation of the low-low alarm • LO_ALM · Violation of the low pre-alarm • DV_HI_ALM · Violation of the limit alarm for upper set point deviation • DV_LO_ALM · Violation of the limit alarm for lower set point deviation • BLOCK_ALM · Block alarm <p>Note: The process alarms can also be deactivated in this parameter group.</p>

AI FB:	<p>ALERT_KEY (4) Read/write capability r/w; supported modes ALL</p> <p>ID number of the plant section</p> <ul style="list-style-type: none"> • 1 to 255, [0] <p>Used by the fieldbus host system to sort alarms and events.</p> <p>Note: '0' is not permissible and will be rejected when transferring data to the device (error alarm).</p>
AI FB:	<p>BLOCK_ALM (21) Read capability r</p> <p>Current block state with details on all configuration, hardware or system problems in the block including date and time stamp.</p>
AI FB:	<p>BLOCK_ERR (6) Read capability r</p> <p>Active block error for AI Function Block</p> <ul style="list-style-type: none"> • OUT OF SERVICE • CONFIGURATION_ERROR
AI FB:	<p>CHANNEL (15) Storage class S; read/write capability r/w; supported modes O</p> <p>Assignment of the output of AI Function Block and the logical hardware channels (Transducer Block).</p> <ul style="list-style-type: none"> • [2] <p>Note: Set CHANNEL to 2 to start up the AI Function Block. This allows it to be assigned to AI TRD.</p>
AI FB:	<p>FIELD_VAL (19) Read capability r</p> <p>Measured value of the Transducer Block in the PV_SCALE unit</p>
AI FB:	<p>GRANT_DENY (12) · This parameter is not supported.</p>
AI FB:	<p>HI_ALM (34) Read capability r</p> <p>Alarm for the high pre-alarm limit (HI_LIM) including details on the date and time as well as the value at which the alarm is triggered.</p> <ul style="list-style-type: none"> • Unit of PV_SCALE

AI FB:	<p>HI_HI_ALM (33) Read capability r</p> <p>Alarm for the high-high alarm limit (HI_HI_LIM) including details on the date and time as well as the value at which the alarm is triggered.</p> <ul style="list-style-type: none"> • Unit of PV_SCALE <p>Note: Additionally, the active alarm can be confirmed manually in this parameter group.</p>
AI FB:	<p>HI_HI_LIM (26) Read/write capability r/w; supported modes ALL</p> <p>High-high alarm limit (HI_HI_ALM)</p> <ul style="list-style-type: none"> • Range and unit of PV_SCALE <p>If PV exceeds this limit, the alarm state parameter HI_HI_ALM is issued.</p>
AI FB:	<p>HI_HI_PRI (25) Read/write capability r/w; supported modes ALL</p> <p>Behavior upon exceeding the high-high alarm limit HI_HI_LIM</p> <ul style="list-style-type: none"> • [0] · The violation of the high-high alarm limit is not analyzed. • 1 · No notification upon violation of the high-high alarm limit • 2 · Reserved for block alarms • 3 to 7 · The violation of the high-high alarm limit is issued to notify the operator with the corresponding priority: (3 = low, 7 = high) • 8 to 15 · The violation of the high-high alarm limit is issued as a critical alarm with the corresponding priority: (8 = low, 15 = high)
AI FB:	<p>HI_LIM (28) Read/write capability r/w; supported modes ALL</p> <p>Alarm limit for the high pre-alarm HI_ALM</p> <ul style="list-style-type: none"> • Range and unit of PV_SCALE, [3402823466 × 10³⁸] <p>If PV exceeds this limit, the alarm state parameter HI_ALM is issued.</p>

AI FB:	<p>HI_PRI (27) Read/write capability r/w; supported modes ALL</p> <p>Behavior upon exceeding the high pre-alarm limit HI_LIM</p> <ul style="list-style-type: none"> • [0] · The violation of the high pre-alarm limit is not analyzed. • 1 · No notification upon violation of the high pre-alarm limit • 2 · Reserved for block alarms • 3 to 7 · The violation of the high pre-alarm limit is issued to notify the operator with the corresponding priority: (3 = low, 7 = high) • 8 to 15 · The violation of the high pre-alarm limit is issued as a critical alarm with the corresponding priority: (8 = low, 15 = high)
AI FB:	<p>IO_OPTS (13) Storage class S; read/write capability r/w; supported modes O</p> <p>LOW CUTOFF · The output is set to '0' at a value below LOW CUTOFF.</p> <p>UNITS CONVERSION · Channel value is converted into the XD_SCALE unit.</p>
AI FB:	<p>L_TYPE (16) Storage class S; read/write capability r/w; supported modes M/O</p> <p>Determines whether the measured values from the AI Function Block can be directly used (Direct), whether the value exist in different units and must be converted (Indirect) or whether the square root must be calculated (Ind Sqr Root).</p>
AI FB:	<p>LO_ALM (35) Read capability r</p> <p>Alarm for the low pre-alarm limit (LO_LIM) including details on the date and time as well as the value at which the alarm is triggered.</p> <ul style="list-style-type: none"> • Unit of PV_SCALE
AI FB:	<p>LO_LIM (30) Read/write capability r/w; supported modes ALL</p> <p>Alarm limit for the low pre-alarm LO_ALM</p> <ul style="list-style-type: none"> • Range and unit of PV_SCALE, $[-3402823466 \times 10^{38}]$ <p>If PV falls below this limit, the alarm state parameter LO_ALM is issued.</p>
AI FB:	<p>LO_LO_ALM (36) Read capability r</p> <p>Alarm for the low-low alarm limit (LO_LO_LIM) including details on the date and time as well as the value at which the alarm is triggered.</p> <ul style="list-style-type: none"> • Unit of PV_SCALE <p>Note: Additionally, the active alarm can be confirmed manually in this parameter group.</p>

AI FB:	<p>LO_LO_LIM (32) Read/write capability r/w; supported modes ALL</p> <p>Alarm limit for the low-low alarm LO_LO_ALM</p> <ul style="list-style-type: none"> • Range and unit of PV_SCALE, $[-3402823466 \times 10^{38}]$ <p>If PV falls below this limit, the alarm state parameter LO_LO_ALM is issued.</p>
AI FB:	<p>LO_LO_PRI (31) Read/write capability r/w; supported modes ALL</p> <p>Behavior upon falling below the low-low alarm limit LO_LO_LIM</p> <ul style="list-style-type: none"> • [0] · The violation of the low-low alarm limit is not analyzed. • 1 · No notification upon violation of the low-low alarm limit • 2 · Reserved for block alarms • 3 to 7 · The violation of the low-low alarm limit is issued to notify the operator with the corresponding priority: (3 = low, 7 = high) • 8 to 15 · The violation of the low-low alarm limit is issued as a critical alarm with the corresponding priority: (8 = low, 15 = high)
AI FB:	<p>LO_PRI (29) Read/write capability r/w; supported modes ALL</p> <p>Behavior upon falling below the low pre-alarm limit LO_LIM</p> <ul style="list-style-type: none"> • [0] · The violation of the low pre-alarm limit is not analyzed. • 1 · No notification upon violation of the low pre-alarm limit • 2 · Reserved for block alarms • 3 to 7 · The violation of the low pre-alarm limit is issued to notify the operator with the corresponding priority: (3 = low, 7 = high) • 8 to 15 · The violation of the low pre-alarm limit is issued as a critical alarm with the corresponding priority: (8 = low, 15 = high)
AI FB:	<p>LOW_CUT (17) Storage class S; read/write capability r/w; supported modes ALL</p> <p>Limit used when the root function is applied.</p>

AI FB:	<p>MODE_BLK (5) Storage class S; read/write capability r/w; supported modes ALL</p> <p>Operating mode of AI Function Block</p> <ul style="list-style-type: none"> – Target Mode – Actual Mode (read only) – Permitted Mode – Normal Mode (read only) <ul style="list-style-type: none"> • AUTO · The analog input value (FIELD_VAL) is processed by the function block and issued as OUT. • MAN · The output value of the AI Function block can be entered manually by the operator over the OUT parameter. • O/S · The AI Function Block is not executed. The last value is issued at the output OUT.
AI FB:	<p>OUT (8) Read/write capability r/w; supported modes M</p> <p>Primary analog value calculated as the result of the function's execution</p> <ul style="list-style-type: none"> • Output value in the OUT_SCALE unit
AI FB:	<p>OUT_SCALE (11) Storage class S; read/write capability r/w; supported modes O</p> <p>Range of the analog OUT value (start, end, unit and decimal point)</p> <ul style="list-style-type: none"> • [0 to 100 %]
AI FB:	<p>PV (7) Read capability r</p> <p>Process variable of the function block (value and status)</p> <ul style="list-style-type: none"> • Unit from the XD_SCALE parameter group.
AI FB:	<p>PV_FTIME (18) Storage class S; read/write capability r/w; supported modes ALL</p> <p>Time constant of a single exponential filter for PV</p>
AI FB:	<p>SIMULATE (9) Read/write capability r/w; supported modes ALL</p> <p>Simulation · Discrete input value (FIELD_VAL) with status</p> <p>Note: The simulation can only be activated if it is enabled at the positioner (Code 48 F3) and in the function block.</p>

AI FB:	ST_REV (1) Read capability r Static revision number (AO Function Block) Note: The revision number is incremented with each change of a static parameter in the block.
AI FB:	STATUS_OPTS (14) Storage class S; read/write capability r/w; supported modes ALL Status options to determine status handling and processing <ul style="list-style-type: none"> • PROPAGATE FAULT FORWARD · In the event of sensor failure, the corresponding status is passed on to the downstream function blocks without generating an alarm. • UNCERTAIN IF LIMITED · The measured value is set to the UNCERTAIN status if the measured value is limited. • BAD IF LIMITED · The measured value is set to the BAD status if the measured value is limited. • UNCERTAIN IF MAN MODE · The measured value is set to the UNCERTAIN status if the mode is set to MAN.
AI FB:	STRATEGY (3) Storage class S; read/write capability r/w; supported modes ALL Permits strategic grouping and thus faster processing of blocks <ul style="list-style-type: none"> • [0] Blocks are grouped by entering the same number in the STRATEGY parameter of each block. Note: These data are neither checked nor processed by the AI Function Block.
AI FB:	TAG_DESC (2) Storage class S; read/write capability r/w; supported modes ALL User-specific text for unique identification and assignment of the block <ul style="list-style-type: none"> • Max. 32 characters, [no text]
AI FB:	UPDATE_EVT (20) Read capability r; supported modes ALL Indicates whether static block data have been changed, including date and time stamp
AI FB:	XD_SCALE (10) Storage class S; read/write capability r/w; supported modes O Range of the OUT value (start, end, unit and decimal point) <ul style="list-style-type: none"> • 0.0 to 100.0 %; specified in [%]

Index and parameter assignment: AI Function Block

Index	Parameters
1	ST_REV
2	TAG_DESC
3	STRATEGY
4	ALERT_KEY
5	MODE_BLK
6	BLOCK_ERR
7	PV
8	OUT
9	SIMULATE
10	XD_SCALE
11	OUT_SCALE
12	GRANT_DENY
13	IO_OPTS
14	STATUS_OPTS
15	CHANNEL
16	L_TYPE
17	LOW_CUT
18	PV_FTIME

Index	Parameters
19	FIELD_VAL
20	UPDATE_EVT
21	BLOCK_ALM
22	ALARM_SUM
23	ACK_OPTION
24	ALARM_HYS
25	HI_HI_PRI
26	HI_HI_LIM
27	HI_PRI
28	HI_LIM
29	LO_PRI
30	LO_LIM
31	LO_LO_PRI
32	LO_LO_LIM
33	HI_HI_ALM
34	HI_ALM
35	LO_ALM
36	LO_LO_ALM

9.4 Proportional Integral Derivative Function Block (PID)

PID FB:	ACK_OPTIONS (46) Storage class S; read/write capability r/w; supported modes ALL Automatic alarm acknowledgement (PID Function Block) <ul style="list-style-type: none"> • [UNDEFINED] · No selection • HI_HI_ALM · High-high alarm • HI_ALM · High pre-alarm • LO_LO_ALM · Low-low alarm • LO_ALM · Low pre-alarm • DV_HI_ALM · Limit alarm for upper set point deviation • DV_LO_ALM · Limit alarm for lower set point deviation • BLOCK ALM · Block alarm Note: The alarm is broadcast to the fieldbus host system, but not acknowledged by it.
PID FB:	ALARM_HYS (47) Storage class S; read/write capability r/w; supported modes ALL Hysteresis for the high and low alarm limits <ul style="list-style-type: none"> • 0 to 50 %, [0.5 %] The alarm conditions remain active as long as the measured value remains within the hysteresis. The hysteresis value has an effect on the following alarm limits of the PID Function Block: HI_HI_LIM; HI_LIM; LO_LO_LIM; LO_LIM; DV_HI_LIM; DV_LO_LIM Note: The hysteresis value is a percentage of the PV_SCALE range in the PID Function Block.
PID FB:	ALARM_SUM (45) Storage class S/D; read/write capability r/w; supported modes ALL Current status of process alarms in the PID Function Block <ul style="list-style-type: none"> • HI_HI_ALM · Violation of the high-high alarm • HI_ALM · Violation of the high pre-alarm • LO_LO_ALM · Violation of the low-low alarm • LO_ALM · Violation of the low pre-alarm • DV_HI_ALM · Violation of the limit alarm for upper set point deviation • DV_LO_ALM · Violation of the limit alarm for lower set point deviation • BLOCK ALM · Block alarm Note: The process alarms can also be deactivated in this parameter group.

PID FB:	<p>ALERT_KEY (4)</p> <p>Storage class S; read/write capability r/w; supported modes ALL</p> <p>ID number of the plant section</p> <ul style="list-style-type: none"> • 1 to 255, [0] <p>May be used by the fieldbus host system to sort alarms and events.</p> <p>Note: '0' is not permissible and will be rejected when transferring data to the device (error alarm).</p>
PID FB:	<p>BAL_TIME (25)</p> <p>Storage class S; read/write capability r/w; supported modes ALL</p> <p>Integral-action component windup</p> <p>Time constant to counteract the windup (calculated out value > OUT_HI_LIM or < OUT_LO_LIM) of the integral-action component.</p> <ul style="list-style-type: none"> • [0] <p>Note: If value is '0', windup is removed immediately.</p>
PID FB:	<p>BKCAL_HYS (30)</p> <p>Storage class S; read/write capability r/w; supported modes ALL</p> <p>Hysteresis value for out value range limits (OUT_HI_LIM and OUT_LO_LIM)</p> <ul style="list-style-type: none"> • 0 to 50 %, [0.5 %] <p>If the calculated out value violates the range defined by the limits, the violation is indicated in the OUT parameter and passed on to the following blocks.</p> <p>The range violation remains active as long as the calculated out value does not exceed or fall below the hysteresis value.</p>
PID FB:	<p>BKCAL_IN (27)</p> <p>Storage class N; read/write capability r/w; supported modes ALL</p> <p>Analog input value (value and status)</p> <p>BKCAL_IN is adopted by the BKCAL_OUT parameter of the downstream function block for cascade control. This value ensures bumpless switching between operating modes by tracking the output.</p>
PID FB:	<p>BKCAL_OUT (31)</p> <p>Storage class D; read capability r</p> <p>Analog output value (value and status)</p> <p>BKCAL_OUT is passed on to the BKCAL_IN parameter of the upstream function block for cascade control. It prevents integral windup of the controller and thus ensures bumpless switching between operating modes.</p>

PID FB:	BLOCK_ALM (44) Storage class D; read/write capability r/w; supported modes ALL Current block state with details on all configuration, hardware or system problems in the block including date and time stamp.
PID FB:	BLOCK_ERR (6) Storage class D; read capability r Active block error → Code 48 P8 <ul style="list-style-type: none"> • OUT OF SERVICE · Block mode is out of service • CONFIGURATION ERROR
PID FB:	BYPASS (17) Storage class S; read/write capability r/w; supported modes M/O Activates calculation of the out value through the PID control algorithm <ul style="list-style-type: none"> • UNINITIALIZED · Same as ON • [OFF] · Bypass deactivated: the out value determined by the PID control algorithm is issued over the OUT parameter. • ON · Bypass activated: the value of the set point SP is issued directly over the OUT parameter. <p>Note: UNINITIALIZED causes the function block to remain in O/S mode. To activate the bypass (ON setting), the bypass must be enabled in the control options (CONTROL_OPTS parameter).</p>
PID FB:	CAS_IN (18) Storage class N; read/write capability r/w; supported modes ALL Analog set point (value and status) → Code 48 P2/3 CAS_IN is adopted from an upstream function block.
PID FB:	CONTROL_OPTS (13) Storage class S; read/write capability r/w; supported modes O Control options to determine the automation strategy <ul style="list-style-type: none"> • [NONE] • BYPASS ENABLE • DIRECT ACTING • TRACK ENABLE · Tracking enabled • TRACK IN MANUAL · Tracking in MAN mode • PV FOR BKCAL_OUT · Value and status of PV used for BKCAL_OUT • NO OUT LIMITS IN MANUAL · No output limits in MAN mode

PID FB:	<p>DV_HI_ALM (64)</p> <p>Storage class D; read/write capability r/w; supported modes ALL</p> <p>Alarm for the upper set point deviation (DV_HI_LIM) including details on the date and time as well as the value at which the alarm is triggered.</p> <p>Note: Additionally, the active alarm can be confirmed manually in this parameter group.</p>
PID FB:	<p>DV_HI_LIM (57)</p> <p>Storage class S; read/write capability r/w; supported modes ALL</p> <p>Limit for the upper set point deviation</p> <ul style="list-style-type: none"> • $[3402823466 \times 10^{38}]$ <p>If the controlled variable exceeds the set point by this value, the pre-alarm DV_HI_ALM is issued.</p>
PID FB:	<p>DV_HI_PRI (56)</p> <p>Storage class S; read/write capability r/w; supported modes ALL</p> <p>Behavior upon exceeding the upper set point deviation (DV_HI_LIM)</p> <ul style="list-style-type: none"> • [0] · The violation of the limit for the upper set point deviation is not analyzed. • 1 · No notification upon violation of the limit for the upper set point deviation • 2 · Reserved for block alarms • 3 to 7 · The violation of the limit for the upper set point deviation is issued to notify the operator with the corresponding priority: (3 = low, 7 = high) • 8 to 15 · The violation of the limit for the upper set point deviation is issued as a critical alarm with the corresponding priority: (8 = low, 15 = high)
PID FB:	<p>DV_LO_ALM (65)</p> <p>Storage class D; read capability r</p> <p>Alarm for the lower set point deviation (DV_LO_LIM) including details on the date and time as well as the value at which the alarm is triggered.</p> <p>Note: Additionally, the active alarm can be confirmed manually in this parameter group.</p>
PID FB:	<p>DV_LO_LIM (59)</p> <p>Storage class S; read/write capability r/w; supported modes ALL</p> <p>Limit for the lower set point deviation</p> <ul style="list-style-type: none"> • $[-3402823466 \times 10^{38}]$ <p>If the controlled variable is smaller than the set point by this value, the pre-alarm DV_LO_ALM is issued.</p>

PID FB:	DV_LO_PRI (58) Storage class S; read/write capability r/w; supported modes ALL Behavior upon falling below the lower set point deviation (DV_LO_LIM) <ul style="list-style-type: none"> • [0] · The violation of the limit for the lower set point deviation is not analyzed. • 1 · No notification upon violation of the limit for the lower set point deviation • 2 · Reserved for block alarms • 3 to 7 · The violation of the limit for the lower set point deviation is issued to notify the operator with the corresponding priority: (3 = low, 7 = high) • 8 to 15 · The violation of the limit for the lower set point deviation is issued as a critical alarm with the corresponding priority: (8 = low, 15 = high)
PID FB:	FF_GAIN (42) Storage class S; read/write capability r/w; supported modes M/O Feedforward gain <ul style="list-style-type: none"> • [0] Note: The feedforward gain is multiplied with the input value (FF_VAL). The result is added to the OUT value.
PID FB:	FF_SCALE (41) Storage class S; read/write capability r/w; supported modes M/O Measuring range of FF_VAL input value (lower and upper limits, unit and decimal point) <ul style="list-style-type: none"> • [0 to 100 %]
PID FB:	FF_VAL (40) Storage class N; read/write capability r/w; supported modes ALL Feedforward control input value (value and status) <ul style="list-style-type: none"> • Range and unit of FF_SCALE Note: The input value is multiplied with the feedward gain FF_GAIN. The result is added to the OUT value.
PID FB:	GAIN (23) Storage class S; read/write capability r/w; supported modes ALL Proportional-action coefficient <ul style="list-style-type: none"> • [1.0] Note: The parameter must be set to a value not equal to 0; otherwise, a configuration error is set in the BLOCK_ERR parameter and the block is set to 'Out of service' (O/S) mode.
PID FB:	GRANT_DENY (12) · This parameter is not supported.

PID FB:	HI_ALM (61) Storage class D; read capability r Alarm for the high pre-alarm limit (HI_LIM) including details on the date and time as well as the value at which the alarm is triggered. • Unit of PV_SCALE
PID FB:	HI_HI_ALM (60) Storage class D; read/write capability r/w Alarm for the high-high alarm limit (HI_HI_LIM) including details on the date and time as well as the value at which the alarm is triggered. • Unit of PV_SCALE Note: Additionally, the active alarm can be confirmed manually in this parameter group.
PID FB:	HI_HI_LIM (49) Storage class S; read/write capability r/w; supported modes ALL High-high alarm limit (HI_HI_ALM) • Range and unit of PV_SCALE, [3402823466 x 10 ³⁸] If PV exceeds this limit, the alarm state parameter HI_HI_ALM is issued.
PID FB:	HI_HI_PRI (48) Storage class S; read/write capability r/w; supported modes ALL Behavior upon exceeding the high-high alarm limit HI_HI_LIM • [0] · The violation of the high-high alarm limit is not analyzed. • 1 · No notification upon violation of the high-high alarm limit • 2 · Reserved for block alarms • 3 to 7 · The violation of the high-high alarm limit is issued to notify the operator with the corresponding priority: (3 = low, 7 = high) • 8 to 15 · The violation of the high-high alarm limit is issued as a critical alarm with the corresponding priority: (8 = low, 15 = high)
PID FB:	HI_LIM (51) Storage class S; read/write capability r/w; supported modes ALL Alarm limit for the high pre-alarm HI_ALM • Range and unit of PV_SCALE, [3402823466 x 10 ³⁸] If PV exceeds this limit, the alarm state parameter HI_ALM is issued.

PID FB:	HI_PRI (50) Storage class S; read/write capability r/w; supported modes ALL Behavior upon exceeding the high pre-alarm limit HI_LIM <ul style="list-style-type: none"> • [0] · The violation of the high pre-alarm limit is not analyzed. • 1 · No notification upon violation of the high pre-alarm limit • 2 · Reserved for block alarms • 3 to 7 · The violation of the high pre-alarm limit is issued to notify the operator with the corresponding priority: (3 = low, 7 = high) • 8 to 15 · The violation of the high pre-alarm limit is issued as a critical alarm with the corresponding priority: (8 = low, 15 = high)
PID FB:	IN (15) Storage class N; read/write capability r/w; supported modes ALL Analog controlled variable x (value and status)
PID FB:	LO_ALM (62) Storage class D; read capability r Alarm for the low pre-alarm limit (LO_LIM) including details on the date and time as well as the value at which the alarm is triggered. <ul style="list-style-type: none"> • Unit of PV_SCALE
PID FB:	LO_LIM (53) Storage class S; read/write capability r/w Alarm limit for the low pre-alarm LO_ALM <ul style="list-style-type: none"> • Range and unit of PV_SCALE, $[-3402823466 \times 10^{38}]$ If PV falls below this limit, the alarm state parameter LO_ALM is issued.
PID FB:	LO_LO_ALM (63) Storage class D; read capability r Alarm for the low-low alarm limit (LO_LO_LIM) including details on the date and time as well as the value at which the alarm is triggered. <ul style="list-style-type: none"> • Unit of PV_SCALE Note: Additionally, the active alarm can be confirmed manually in this parameter group.
PID FB:	LO_LO_LIM (55) Storage class S; read/write capability r/w; supported modes ALL Alarm limit for the low-low alarm LO_LO_ALM <ul style="list-style-type: none"> • Range and unit of PV_SCALE, $[-3402823466 \times 10^{38}]$ If PV falls below this limit, the alarm state parameter LO_LO_ALM is issued.

PID FB: LO_LO_PRI (54)

Storage class S; read/write capability r/w; supported modes ALL

Behavior upon falling below the low-low alarm limit LO_LO_LIM

- [0] · The violation of the low-low alarm limit is not analyzed.
- 1 · No notification upon violation of the low-low alarm limit
- 2 · Reserved for block alarms
- 3 to 7 · The violation of the low-low alarm limit is issued to notify the operator with the corresponding priority: (3 = low, 7 = high)
- 8 to 15 · The violation of the low-low alarm limit is issued as a critical alarm with the corresponding priority: (8 = low, 15 = high)

PID FB: LO_PRI (52)

Storage class S; read/write capability r/w; supported modes ALL

Behavior upon falling below the low pre-alarm limit LO_LIM

- [0] · The violation of the low pre-alarm limit is not analyzed.
- 1 · No notification upon violation of the low pre-alarm limit
- 2 · Reserved for block alarms
- 3 to 7 · The violation of the low pre-alarm limit is issued to notify the operator with the corresponding priority: (3 = low, 7 = high)
- 8 to 15 · The violation of the low pre-alarm limit is issued as a critical alarm with the corresponding priority: (8 = low, 15 = high)

PID FB:	MODE_BLK (5) Storage class S; read/write capability r/w; supported modes ALL Operating mode <ul style="list-style-type: none"> – Target Mode → Code 48 P0 – Actual Mode (read only) → Code 48 P1 – Permitted Mode – Normal Mode (read only) • O/S · The PID algorithm of the block is not executed. The last value or the determined value during an active fault processing is issued at the OUT parameter. • MAN · The output value of the function block can be entered manually by the operator over the OUT parameter. • AUTO · The set point entered by the operator is used over the SP parameter upon execution of the PID Function Block. • CAS · The PID Function Block receives the set point directly from an upstream function block over the CAS_IN parameter for internal calculation of the out value. The PID Function Block is implemented. • RCAS · The PID Function Block receives the set point directly from the fieldbus host system over the RCAS_IN parameter for internal calculation of the out value. The PID Function Block is implemented. • ROUT · The PID Function Block receives the out value directly from the fieldbus host system over the ROUT_IN parameter. The out value is issued again over the OUT parameter without the internal PID algorithm being executed.
PID FB:	OUT (9) Storage class S; read/write capability r/w; supported modes O/M Out value of the PID Function Block (value, limit and status) → Code 48 P6/7 <ul style="list-style-type: none"> • Range OUT_SCALE ±10 %, unit of XD_SCALE Note: The OUT value can be entered manually when the MAN mode is selected in the MODE_BLK parameter.
PID FB:	OUT_HI_LIM (28) Storage class S; read/write capability r/w; supported modes ALL Upper limit for analog OUT value <ul style="list-style-type: none"> • Range OUT_SCALE ±10 %, unit of OUT_SCALE, [100]
PID FB:	OUT_LO_LIM (29) Storage class S; read/write capability r/w; supported modes ALL Lower limit for analog OUT value <ul style="list-style-type: none"> • Range OUT_SCALE ±10 %, unit of OUT_SCALE, [0]

PID FB:	OUT_SCALE (11) Storage class S; read/write capability r/w; supported modes O Range of the analog OUT value (start, end, unit and decimal point) • [0 to 100 %]
PID FB:	PV (7) Storage class D; read capability r Process variable for block execution (value and status) • Unit of PV_SCALE
PID FB:	PV_FTIME (16) Storage class S; read/write capability r/w; supported modes ALL Filter time constant [s] of the first-order digital filter • [0] This time is required for 63 % of a change in the controlled variable at input IN to take effect in the value of PV.
PID FB:	PV_SCALE (10) Storage class S; read/write capability r/w; supported modes O Range of the process variable (PV) (start, end, unit and decimal point) • [0 to 100 %]
PID FB:	RATE (26) Storage class S; read/write capability r/w; supported modes ALL Time constant [s] for differential function • [0]
PID FB:	RCAS_IN (32) Storage class N; read/write capability r/w; supported modes ALL Analog set point for internal calculation of the out value (value and status) RCAS_IN is provided by the fieldbus host system. Note: This parameter is only active in RCAS mode.
PID FB:	RCAS_OUT (35) Storage class D; read capability r Analog set point after applying the ramp function (value and status) RCAS_OUT value is provided to the fieldbus host system to perform back-calculations in case of control mode changes or limited signals. Note: This parameter is only active in RCAS mode.

PID FB:	<p>RESET (24)</p> <p>Storage class S; read/write capability r/w</p> <p>Time constant for integral function</p> <ul style="list-style-type: none"> • [3402823466 × 10³⁸] (maximum possible value) <p>Note: The cold start value or '0' switches off the integral function.</p>
PID FB:	<p>ROUT_IN (33)</p> <p>Storage class N; read/write capability r/w; supported modes ALL</p> <p>Out value (value and status)</p> <p>ROUT_IN is provided by the fieldbus host system.</p> <p>Note: This parameter is only active in ROUT mode.</p>
PID FB:	<p>ROUT_OUT (36)</p> <p>Storage class D; read capability r</p> <p>Analog set point (value and status) read over the ROUT_IN parameter</p> <p>ROUT_OUT value is provided to the fieldbus host system to perform back-calculations in case of control mode changes or limited signals.</p> <p>Note: This parameter is only active in ROUT mode.</p>
PID FB:	<p>SHED_OPT (34)</p> <p>Storage class S; read/write capability r/w; supported modes ALL</p> <p>Behavior upon exceeding the monitoring time (SHED_RCAS parameter in the RES block) while checking the connection between the fieldbus host system and the PID Function Block in RCAS or ROUT.</p> <p>When the monitoring time has elapsed, PID Function Block switches from RCAS or ROUT to the selected operating mode. The action to be taken after the fault state ends is also determined.</p> <ul style="list-style-type: none"> • [UNINITIALIZED] • NORMAL SHED_NORMAL RETURN · On failure of remote connection, change to next possible mode until RCAS or ROUT mode is restored. • NORMAL SHED_NO RETURN · On failure of remote connection, change to next possible mode. The block remains in this mode.

- SHED TO AUTO_NORMAL RETURN · On failure of remote connection, change to AUTO mode until RCAS or ROUT mode is restored.
- SHED TO AUTO_NO RETURN · On failure of remote connection, change to AUTO mode. No attempt is made to restore the mode and the block remains in AUTO mode.
- SHED TO MANUAL_NORMAL RETURN · On failure of remote connection, change to MAN mode until RCAS or ROUT mode is restored.
- SHED TO MANUAL_NO RETURN · On failure of remote connection, change to MAN mode. No attempt is made to restore the mode and the block remains in MAN mode.
- SHED TO RETAINED_TARGET_NORMAL RETURN · On failure of remote connection, the block attempts to attain the retained target mode until RCAS or ROUT mode is restored.
- SHED TO RETAINED_TARGET_NO RETURN · On failure of remote connection, the block sets the target mode to the retained target mode.

Note: This parameter is only active in RCAS and ROUT modes in the PID Function Block. If the value is set to UNINITIALIZED, the PID Function Block cannot be placed in the RCAS or ROUT mode.

PID FB: SP (8)

Storage class N; read/write capability r/w; supported modes O/M/A

Set point w in AUTO mode (value and status) → Code 48 P4/5

- Value and range from PV_SCALE ±10 %

PID FB: SP_HI_LIM (21)

Storage class S; read/write capability r/w; supported modes ALL

Upper set point limit

- Value and range from PV_SCALE ±10 %, [100]

Note: Adapt this value accordingly if the end-of-scale value in the PV_SCALE parameter is changed.

PID FB: SP_LO_LIM (22)

Storage class S; read/write capability r/w; supported modes ALL

Lower set point limit

- Value and range from PV_SCALE ±10 %, [0]

Note: Adapt this value accordingly if the end-of-scale value in the PV_SCALE parameter is changed.

PID FB:	<p>SP_RATE_DN (19)</p> <p>Storage class S; read/write capability r/w; supported modes ALL</p> <p>Set point downward rate limit in AUTO mode</p> <ul style="list-style-type: none"> • [3402823466 × 10³⁸] <p>Note: if '0' is entered, the set point is used. Speed limitation for control blocks is only active in AUTO mode.</p>
PID FB:	<p>SP_RATE_UP (20)</p> <p>Storage class S; read/write capability r/w; supported modes ALL</p> <p>Set point upward rate limit in AUTO mode</p> <ul style="list-style-type: none"> • [3402823466 × 10³⁸] <p>Note: if '0' is entered, the set point is used. Speed limitation for control blocks is only active in AUTO mode.</p>
PID FB:	<p>ST_REV (1)</p> <p>Storage class S; read capability r</p> <p>Static revision number (PID)</p> <p>Note: The revision number is incremented with each change of a static parameter in the block.</p>
PID FB:	<p>STATUS_OPTS (14)</p> <p>Storage class S; read/write capability r/w; supported modes O</p> <p>Status options to determine status handling and processing</p> <ul style="list-style-type: none"> • [UNINITIALIZED] • IFS IF BAD IN · Fault state of the downstream AO Function Block is triggered when the controlled variable IN changes the status to BAD. • IFS IF BAD CAS_IN · Fault state of the downstream AO Function Block is triggered when the external set point CAS_IN changes the status to BAD. • USE UNCERTAIN AS GOOD · The UNCERTAIN status is used as GOOD • TARGET IN MANUAL IF BAD IN · Transition to MAN mode if the controlled variable changes the status to BAD
PID FB:	<p>STRATEGY (3)</p> <p>Storage class S; read/write capability r/w; supported modes ALL</p> <p>Permits strategic grouping and thus faster processing of blocks</p> <ul style="list-style-type: none"> • [0] <p>Blocks are grouped by entering the same number in the STRATEGY parameter of each block.</p> <p>Note: These data are neither checked nor processed by the PID Function Block.</p>

PID FB:	TAG_DESC (2) Storage class S; read/write capability r/w; supported modes ALL User-specific text for identification and assignment of the block • Max. 32 characters, [no text]
PID FB:	TRK_IN_D (38) Storage class N; read/write capability r/w; supported modes ALL Discrete input that activates external output tracking (value and status) Mode is changed to LO after tracking has been activated. The output value at OUT assumes the value defined by the TRK_VAL input.
PID FB:	TRK_SCALE (37) Storage class S; read/write capability r/w; supported modes O/M Range for external tracking value (TRK_VAL) (start, end, unit and decimal point) • [0 to 100 %]
PID FB:	TRK_VAL (39) Storage class N; read/write capability r/w; supported modes ALL Analog input for external tracking (value and status) TRK_VAL is read from another function block.
PID FB:	UPDATE_EVT (43) Storage class D; read capability r Indicates whether static data have been changed, including date and time stamp.

Index and parameter assignment: PID Function Block

Index	Parameters
0	–
1	ST_REV
2	TAG_DESC
3	STRATEGY
4	ALERT_KEY
5	MODE_BLK
6	BLOCK_ERR
7	PV
8	SP
9	OUT
10	PV_SCALE
11	OUT_SCALE
12	GRANT_DENY
13	CONTROL_OPTS
14	STATUS_OPTS
15	IN
16	PV_FTIME
17	BYPASS
18	CAS_IN
19	SP_RATE_DN
20	SP_RATE_UP
21	SP_HI_LIM
22	SP_LO_LIM
23	GAIN
24	RESET
25	BAL_TIME
26	RATE
27	BKCAL_IN
28	OUT_HI_LIM
29	OUT_LO_LIM
30	BKCAL_HYS

Index	Parameters
31	BKCAL_OUT
32	RCAS_IN
33	ROUT_IN
34	SHED_OPT
35	RCAS_OUT
36	ROUT_OUT
37	TRK_SCALE
38	TRK_IN_D
39	TRK_VAL
40	FF_VAL
41	FF_SCALE
42	FF_GAIN
43	UPDATE_EVT
44	BLOCK_ALM
45	ALARM_SUM
46	ACK_OPTIONS
47	ALARM_HYS
48	HI_HI_PRI
49	HI_HI_LIM
50	HI_PRI
51	HI_LIM
52	LO_PRI
53	LO_LIM
54	LO_LO_PRI
55	LO_LO_LIM
56	DV_HI_PRI
57	DV_HI_LIM
58	DV_LO_PRI
59	DV_LO_LIM
60	HI_HI_ALM
61	HI_ALM

Parameter lists

Index	Parameters
62	LO_ALM
63	LO_LO_ALM

Index	Parameters
64	DV_HI_ALM
65	DV_LO_ALM

9.5 Discrete Output Function Block (DO FB)

DO FB:	ALERT_KEY (4) Storage class S; read/write capability r/w; supported modes ALL ID number of the plant section <ul style="list-style-type: none"> • 1 to 255, [0] Used by the fieldbus host system to sort alarms and events. Note: '0' is not permissible and will be rejected when transferring data to the device (error alarm).
DO FB:	BKCAL_OUT_D (21) Storage class D; read capability r Discrete output value for upstream block (value and status) BKCAL_OUT_D is passed on to the BKCAL_IN parameter of the upstream function block for cascade control. It prevents integral windup of the controller and thus ensures bumpless switching between operating modes.
DO FB:	BLOCK_ALM (26) Storage class D; read capability r Current block state with details on all configuration, hardware or system problems in the block including date and time stamp.
DO FB:	BLOCK_ERR (6) Storage class D; read capability r Active block error Code 48 A8 <ul style="list-style-type: none"> • OUT OF SERVICE • CONFIGURATION_ERROR
DO FB:	CAS_IN_D (17) Storage class N; read/write capability r/w; supported modes ALL Discrete set point from upstream function block (value and status)
DO FB:	CHANNEL (18) Storage class S; read/write capability r/w; supported modes O Assignment of the output of DO Function Block and the logical hardware channels (Transducer Block). <ul style="list-style-type: none"> • [6] in DO1 FB and [7] in DO2 FB Note: Set CHANNEL to 6 to start up the DO1 Function Block. This allows it to be assigned to DO1 TRD. Set CHANNEL to 7 to start up the DO2 Function Block. This allows it to be assigned to DO2 TRD.

DO FB:	<p>FSTATE_TIME (19)</p> <p>Storage class S; read/write capability r/w; supported modes ALL</p> <p>Fault state time [s]</p> <p>Time between an error in the set point valid for the DO Function Block in the current operating mode is detected and failure action is triggered.</p> <ul style="list-style-type: none"> • [0] <p>Note: Failure action is triggered if the error persists after this time has elapsed. The fault state of the DO Function Block is determined in the IO_OPTS parameter of this block.</p>
DO FB:	<p>FSTATE_VAL_D (20)</p> <p>Storage class S; read/write capability r/w; supported modes ALL</p> <p>Fault state value for the DO Function Block when failure action is triggered.</p> <ul style="list-style-type: none"> • Value and range from PV_SCALE $\pm 10\%$, [0] <p>Note: The value is used if the FAULT STATE TO VALUE option is selected in the IO_OPTS parameter.</p>
DO FB:	<p>GRANT_DENY (13) - This parameter is not supported.</p>
DO FB:	<p>IO_OPTS (14)</p> <p>Storage class S; read/write capability r/w; supported modes O</p> <p>Selects the input/output behavior of the DO Function Block.</p> <ul style="list-style-type: none"> • INVERTIERT · Inversion of SP_D • SP-PV TRACK IN MAN · SP tracks PV in MAN mode (Actual Mode) • SP-PV TRACK IN LO · SP tracks PV in LO mode (Actual Mode) • SP TRACK RETAINED TARGET · SP tracks RCAS_IN or CAS_IN depending on the preset target mode in LO or MAN mode (actual mode). This option has priority over SP-PV TRACK IN MAN/LO. • FAULT STATE TO VALUE · FSTATE_VAL_D is used as the set point when the failure action is triggered (see FSTATE_VAL_D, FSTATE_TIME) • USE FAULT STATE VALUE ON RESTART · FSTATE_VAL_D is used as the set point upon restarting until a valid value has been entered. • TARGET TO MAN IF FAULT STATE ACTIVATED · When failure action is triggered, the target mode is set to MAN and the original target mode is lost. The block remains in MAN mode after failure action has been left until the user sets it to the desired operating mode. • USE PV FOR BKCAL_OUT · The PV_D process value is fed back at BKCAL_OUT instead of the working process value.

DO FB:	MODE_BLK (5) Storage class N; read/write capability r/w; supported modes ALL Operating mode of DO Function Block <ul style="list-style-type: none"> – Target Mode – Actual Mode (read only) – Permitted Mode – Normal Mode (read only) • AUTO · The discrete set point entered by the operator is used over the SP_D parameter upon execution of the DO Function Block. • MAN · The discrete output value of the DO Function Block can be entered manually by the operator over the OUT_D parameter. • CAS · The DO Function Block receives the discrete set point directly from an upstream function block over the CAS_IN_D parameter for internal processing of the out value. The DO Function Block is implemented. • RCAS · The DO Function Block receives the discrete set point directly from the fieldbus host system over the RCAS_IN_D parameter for internal processing of the out value. The DO Function Block is implemented. • O/S · The DO Function Block is not executed. The last value or the determined value during an active fault processing is issued at the OUT_D parameter.
DO FB:	OUT_D (9) Storage class S; read/write capability r/w; supported modes O/M Out value of the DO Function Block (value, limit and status) <ul style="list-style-type: none"> • Range of OUT_SCALE $\pm 10\%$; unit of the XD_SCALE parameter group Note: The OUT value can be entered manually when the MAN mode is selected in the MODE_BLK parameter.
DO FB:	PV_D (7) Storage class D; read capability r Discrete process variable used to execute the module (value and status)
DO FB:	PV_STATE (11) Storage class S; read/write capability r/w; supported modes ALL Status of PV_D and SP_D parameters
DO FB:	RCAS_IN_D (22) Storage class N; read/write capability r/w; supported modes ALL Discrete set point for internal calculation of the out value (value and status) RCAS_IN_D value is provided by the fieldbus host system. Note: This parameter is only active in RCAS mode.

DO FB:	<p>RCAS_OUT_D (24) Storage class D; read capability r</p> <p>Discrete set point after applying the ramp function (value and status) The RCAS_OUT_D value is provided to the fieldbus host system to perform back-calculations in case of control mode changes or limited signals.</p> <p>Note: This parameter is only active in RCAS mode.</p>
DO FB:	<p>READBACK_D (16) Storage class D; read capability r</p> <p>Current discrete valve position</p> <ul style="list-style-type: none"> • 0: 0 % 1: 100 % • 2: Intermediate position (0.5 % < x < 99.5 %)
DO FB:	<p>SHED_OPT (23) Storage class S; read/write capability r/w; supported modes ALL</p> <p>Behavior upon exceeding the monitoring time (see SHED_RCAS in the Resource Block) Monitoring of the connection between fieldbus host system and DO Function Block in RCAS mode. When the monitoring time has elapsed, DO Function Block switches from the RCAS mode to the selected operating mode.</p> <p>The action to be taken after the fault state ends is also determined.</p> <ul style="list-style-type: none"> • [UNINITIALIZED] • NORMAL SHED_NORMAL RETURN · On failure of remote connection, change to next possible mode until RCAS mode is restored. • NORMAL SHED_NO RETURN · On failure of remote connection, change to next possible mode. The block remains in this mode. • SHED TO AUTO_NORMAL RETURN · On failure of remote connection, change to AUTO mode until RCAS mode is restored. • SHED TO AUTO_NO RETURN · On failure of remote connection, change to AUTO mode. No attempt is made to restore the mode and the block remains in AUTO mode. • SHED TO MANUAL_NORMAL RETURN · On failure of remote connection, change to MAN mode until RCAS mode is restored. • SHED TO MANUAL_NO RETURN · On failure of remote connection, change to MAN mode. No attempt is made to restore the mode and the block remains in MAN mode. • SHED TO RETAINED TARGET_NORMAL RETURN · On failure of remote connection, the block attempts to attain the retained target mode until RCAS mode is restored. • SHED TO RETAINED TARGET_NO RETURN · On failure of remote connection, the block sets the target mode to the retained target mode. <p>Note: This parameter is only active in RCAS mode in the DO Function Block. If the value is set to UNINITIALIZED, the DO Function Block cannot be placed in the RCAS mode.</p>

DO FB:	SIMULATE_D (10) Storage class D; read/write capability r/w; supported modes ALL Simulation of the process variable PV_D of the block (value and status) Note: During simulation, OUT_D is not transmitted to the Transducer Block; the block retains the last valid value received before simulation was activated. The simulation can only be activated when SIMULATE ACTIVE is set in the BLOCK_ERR parameter of the Resource Block.
DO FB:	SP_D (8) Storage class N; read/write capability r/w; supported modes O/M/A Discrete set point (reference variable) in AUTO mode
DO FB:	ST_REV (1) Storage class N; read capability r Static revision number Note: The revision number is incremented with each change of a static parameter in the block.
DO FB:	STATUS_OPTS (15) Storage class S; read/write capability r/w; supported modes O Options for status handling <ul style="list-style-type: none"> • UNCERTAIN as GOOD · The status of OUT is set to GOOD if the status of the input value IN_x is UNCERTAIN. • UNCERTAIN IF MAN MODE · The status of OUT is set to UNCERTAIN if the actual mode is set to MAN.
DO FB:	STRATEGY (3) Storage class S; read/write capability r/w; supported modes ALL Permits strategic grouping and thus faster processing of blocks <ul style="list-style-type: none"> • [0] Blocks are grouped by entering the same number in the STRATEGY parameter of each block. Note: These data are neither checked nor processed by the DO Function Block.
DO FB:	TAG_DESC (2) Storage class S; read/write capability r/w; supported modes ALL User-specific text for unique identification and assignment of the block <ul style="list-style-type: none"> • Max. 32 characters, [no text]

Parameter lists

DO FB: UPDATE_EVT (25)
Storage class D; read capability r
Indicates whether static block data have been changed, including date and time stamp

DO FB: XD_STATE (12)
Storage class S; read/write capability r/w; supported modes ALL
Status of OUT_D and READBACK_D parameters

Index and parameter assignment: DO Function Block

Index	Parameters
0	–
1	ST_REV
2	TAG_DESC
3	STRATEGY
4	ALERT_KEY
5	MODE_BLK
6	BLOCK_ERR
7	PV_D
8	SP_D
9	OUT_D
10	SIMULATE_D
11	PV_STATE
12	XD_STATE
13	GRANT_DENY

Index	Parameters
14	IO_OPTS
15	STATUS_OPTS
16	READBACK_D
17	CAS_IN_D
18	CHANNEL
19	FSTATE_TIME
20	FSTATE_VAL_D
21	BKCAL_OUT_D
22	RCAS_IN_D
23	SHED_OPT
24	RCAS_OUT_D
25	UPDATE_EVT
26	BLOCK_ALM

9.6 Discrete Input Function Block (DI1 FB + DI2 FB)

DI FB:	ACK_OPTIONS (21) Storage class S; read/write capability r/w; supported modes O/M/A Automatic alarm acknowledgement (DI Function Block) <ul style="list-style-type: none"> • [UNDEFINED] · No selection • BLOCK ALM · Block alarm • DISC ALM · Write protection was changed Note: The alarm is broadcast to the fieldbus host system, but not acknowledged by it.
DI FB:	ALARM_SUM (20) Storage class S/D; read/write capability r/w; supported modes O/M/A Current status of process alarms in the DI Function Block <ul style="list-style-type: none"> • BLOCK ALM · Block alarm • DISC ALM · Write protection was changed Note: The process alarms can also be deactivated in this parameter group.
DI FB:	ALERT_KEY (4) Storage class S; read/write capability r/w; supported modes O/M/A ID number of the plant section <ul style="list-style-type: none"> • 1 to 255, [0] Used by the fieldbus host system to sort alarms and events. Note: '0' is not permissible and will be rejected when transferring data to the device (error alarm).
DI FB:	BLOCK_ALM (19) Storage class D; read capability r Current block state with details on all configuration, hardware or system problems in the block including date and time stamp.
DI FB:	BLOCK_ERR (6) Storage class D; read capability r Active block error Code 48 I6 for DI1, Code 48 L6 for DI2 <ul style="list-style-type: none"> • OUT OF SERVICE • CONFIGURATION_ERROR

DI FB:	CHANNEL (15)
	Storage class S; read/write capability r/w; supported modes O
	Assignment of the output of DI Function Block and the logical hardware channels (Transducer Block) [1] in DI1 Function Block and [2] in DI2 Function Block
	Note: Set CHANNEL to 1 to start up the DI1 Function Block. This allows it to be assigned to DI1 TRD. Set CHANNEL to 2 to start up the DI2 Function Block. This allows it to be assigned to DI2 TRD.
DI FB:	DISC_ALM (24)
	Storage class D; read capability r
	Discrete alarm (status, time and date of alarm, value that triggered the alarm)
	The value entered in DISC_LIM parameter is exceeded.
	Note: Additionally, the active alarm can be confirmed manually in this parameter group.
DI FB:	DISC_LIM (23)
	Storage class S; read/write capability r/w; supported modes O/M/A
	Limit for discrete alarm
	• [0], 1
DI FB:	DISC_PRI (22)
	Storage class S; read/write capability r/w; supported modes O/M/A
	Alarm configuration (behavior on reaching the DISC_LIM limit)
	• [0] · The violation of the limit is not analyzed.
	• 1 · No notification upon violation of the limit
	• 2 · Reserved for block alarms
	• 3 to 7 · The violation of the limit is issued to notify the operator with the corresponding priority: (3 = low, 7 = high)
DI FB:	FIELD_VAL_D (17)
	Storage class N; read capability r
	Discrete input variable of the DI Function Block (value and status) → Code 48 I2/3 for DI1, Code 48 L2/3 for DI2
DI FB:	GRANT_DENY (12) · This parameter is not supported.
DI FB:	IO_OPTS (13)
	Storage class S; read/write capability r/w; supported modes O
	Selects the input/output behavior of the DI Function Block.
	• INVERT · Sets a logic NOT operation between the input FIELD_VAL_D and output OUT_D.

DI FB:	MODE_BLK (5) Storage class N; read/write capability r/w; supported modes O/M/A Operating mode – Target Mode (Code 48 t4 for DI1 → Code 48 t7 for DI2) – Actual Mode (read only) – Permitted Mode – Normal Mode (read only) • O/S · The DI Function Block is not executed. The last value is issued at the output OUT_D. • MAN · The output value of the DI Function Block can be entered manually by the operator over the OUT_D parameter. • AUTO · The binary input value (FIELD_VAL_D) is processed by the function block and issued as OUT_D.
DI FB:	OUT_D (8) Storage class S; read/write capability r/w; supported modes O/M Discrete output variable (value and status) → Code 48 I4/5 for DI1 → Code 48 L4/5 for DI2
DI FB:	PV_D (7) Storage class D; read capability r Indicates the discrete state (including status) used for the function block. Note: In AUTO mode, the PV_D parameter is identical with output OUT_D.
DI FB:	PV_FTIME (16) Storage class S; read/write capability r/w; supported modes O/M/A Filter time constant [s] of the digital filter until a binary state at the input of the function block is adopted in the PV_D parameter. • [0]
DI FB:	SIMULATE_D (9) Storage class S; read/write capability r/w; supported modes O/M/A Simulation: Input of the discrete input value (FIELD_VAL_D) with status Note: The simulation can only be activated if it is enabled at the positioner (Code 48 F3) and in the function block.

DI FB:	<p>STATUS_OPTS (14) Storage class S; read/write capability r/w; supported modes O</p> <p>Storage options to determine status handling and processing</p> <ul style="list-style-type: none"> • [UNINITIALIZED] • PROPAGATE FAIL FWD · Fault state is passed on to the downstream block
DI FB:	<p>STRATEGY (3) Storage class S; read/write capability r/w; supported modes O/M/A</p> <p>Permits strategic grouping and thus faster processing of blocks</p> <p>[0]</p> <p>Blocks are grouped by entering the same number in the STRATEGY parameter of each block.</p> <p>Note: These data are neither checked nor processed by the DI Function Block.</p>
DI FB:	<p>ST_REV (1) Storage class N; read capability r</p> <p>Static revision number (DI)</p> <p>Note: The revision number is incremented with each change of a static parameter in the block.</p>
DI FB:	<p>TAG_DESC (2) Storage class S; read/write capability r/w; supported modes O/M/A</p> <p>User-specific text for unique identification and assignment of the block</p> <ul style="list-style-type: none"> • Max. 32 characters, [no text]
DI FB:	<p>UPDATE_EVT (18) Storage class D; read capability r</p> <p>Indicates whether static block data have been changed, including date and time stamp</p>

Index and parameter assignment: DI Function Block

Index	Parameters
0	–
1	ST_REV
2	TAG_DESC
3	STRATEGY
4	ALERT_KEY
5	MODE_BLK
6	BLOCK_ERR
7	PV_D
8	OUT_D
9	SIMULATE_D
12	GRANT_DENY
13	IO_OPTS

Index	Parameters
14	STATUS_OPTS
15	CHANNEL
16	PV_FTIME
17	FIELD_VAL_D
18	UPDATE_EVT
19	BLOCK_ALM
20	ALARM_SUM
21	ACK_OPTIONS
22	DISC_PRI
23	DISC_LIM
24	DISC_ALM



SAMSON AG · MESS- UND REGELTECHNIK
Weismüllerstraße 3 · 60314 Frankfurt am Main, Germany
Phone: +49 69 4009-0 · Fax: +49 69 4009-1507
samson@samson.de · www.samson.de

KH 8384-5 EN

2018-01-23 · English