



# Boiler controllers tested according to DIN EN 14597



## Type 5 D

### Application

Flow temperature control in hot water boilers using solid fuels  
Horizontal or vertical installation

The controllers are tested according to DIN EN 14597, for plants according to DIN EN 12828.

### Version

The controllers operate according to the liquid expansion principle. Any temperature changes at the thermostat result in a proportional change in lever travel.

The lever causes the supply air damper at the boiler to close, reducing the energy supply.

The boiler controllers consist of a thermostat, set point adjustment knob, actuating lever and chain.

### Principle of operation

The thermowell contains the liquid-filled thermostat (6), which senses the water supply temperature in the boiler. A pin (5) fastened to the bottom of the metal bellows (4) projects out of the thermostat and is fixed inside the knob (1) used to adjust the temperature. The system consisting of the thermostat and the pin is pressed by the spring (3) against a bearing in the knob. This allows the set point to be adjusted.

The thermostat is connected to a pivot joint (2), to which the actuating lever (8) to control the damper position is fastened. The force of the spring (3) is calculated such that the weight of the control damper is balanced and does not cause a change in the boiler. The spring also acts as a safeguard against excess temperatures.

When the flow temperature rises, the liquid in the temperature sensor (6) expands and pushes the thermostat down since the pin (5) is fixed inside the knob (1). The pivot joint moves and turns the actuating lever axially. The chain (9) causes the damper to close accordingly. In this way, the energy supplied to the boiler is reduced and the boiler temperature falls.

If the flow temperature is reduced, the damper opens according to the set point adjustment.

The temperature set point is changed by turning the set point adjustment knob. This causes the thermostat and pin to move axially. For example, a higher temperature set point causes the damper to open until the adjusted set point is reached.

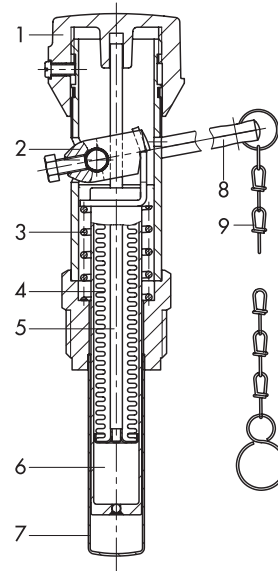

- 1 Knob for set point adjustment
- 2 Pivot joint
- 3 Spring to safeguard against excess temperature and to balance the weight of the damper
- 4 Metal bellows
- 5 Pin
- 6 Temperature sensor filled with expanding liquid
- 7 Thermowell
- 8 Actuating lever
- 9 Chain

Fig. 1: Type 5 D

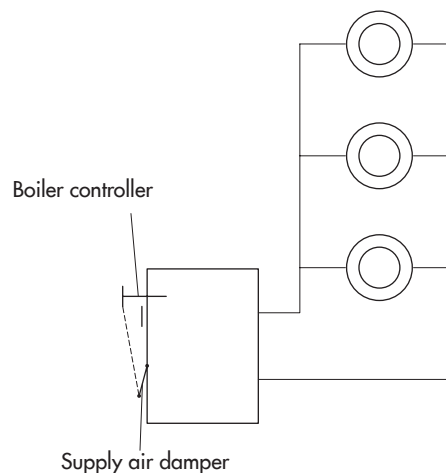

Fig. 2: Functional drawing of Type 5 D Boiler Controller

**Table 1:** Technical data · All pressure stated as gauge pressure

Type 5 D Boiler Controller	
Functioning principle according to DIN EN 14597	Type 1
Connecting thread	G ¾
Set point range	30 to 100 °C
Excess temperature safeguard	50 °C above the adjusted set point
Max. permissible temperature	130 °C
Max. perm. pressure at the sensor	10 bar
Transfer coefficient	0.3 °C/K
Torque	1.9 Nm
Max. travel	85 mm

### Installation

- Suitable for horizontal or vertical installation
- The red inscription on the set point adjustment knob apply when the controller is installed horizontally and the white inscription when it is installed in the upright position.
- Special versions (on customer request)  
The thermowell, chain length and actuating lever can be adapted to the boiler construction and therefore their dimensions may vary as a result.

### Ordering text

**Type 5 D** Boiler Controller

G ¾ connecting thread

**Table 2:** Materials

Thermowell	Brass
Set point adjustment knob	Plastic
Actuating lever	Painted steel
Chain	Zinc-coated steel (gloss finish)

### Dimensions and weights

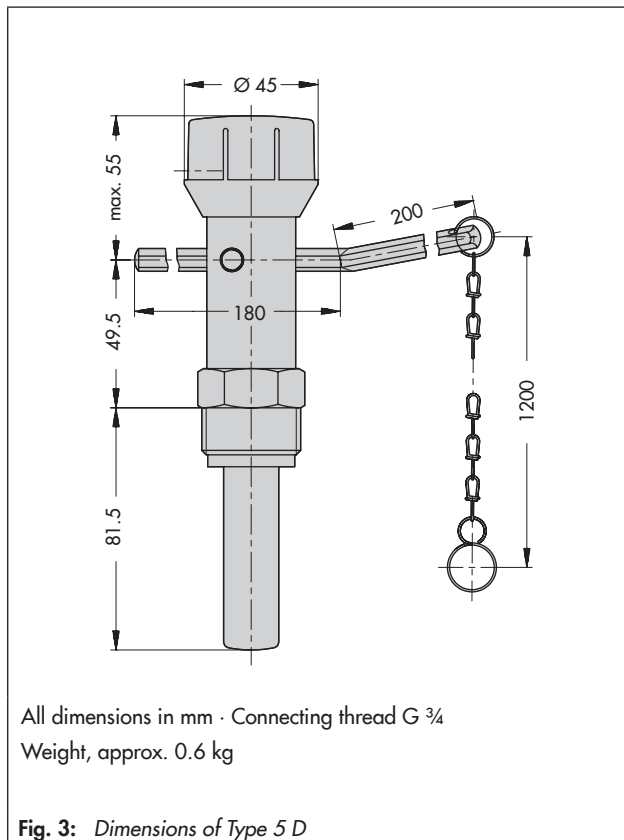

# Steam traps

## Type 13 E Steam Trap

### Application

Condensate discharge from steam-heated systems, heat exchangers, heating batteries, radiators, steam pipes and similar systems · Liquid evaporation principle · PN 16 · Operating range 0.01 to 10 bar · 200 °C · Available as angle or globe valve · Threaded connection

### Versions

The steam trap consists of a body, operating element, seat and plug. It is controlled by the temperature and pressure. It works according to the vapor pressure principle.

The operating element of the steam trap is a metal bellows filled with a water/alcohol mixture. Any changes in temperature at the bellows result in a corresponding change in the plug travel position, causing the free area between the seat and plug to become smaller or larger.

### Principle of operation

The steam pressure curve of the liquid/vapor mixture in the metal bellows largely corresponds to that of water. When the temperature of the water/alcohol mixture rises, it causes the pressure in the operating element to rise. The plug closes the seat opening. In the closed state, the accumulated condensate cools down, causing the temperature of the water/alcohol mixture to fall. As a result, the pressure in the operating element falls and the valve opens, allows the condensate and any trapped air to escape. The temperature of the escaping condensate is approx. 5 to 10 °C below the saturated steam curve.

### Installation

Changing the position of the blanking plug (5) allows the steam trap to be used either as an angle or globe valve.

- Install the steam trap in horizontal pipelines only.
- Direction of flow must match the direction indicated by the arrow on the body.
- Install the condensate discharge pipe with a downward slope of approx. 1 %.
- Install the steam trap directly at the outlet of equipment.
- For equipment in which the heating battery is to be kept free of condensate: Install the steam trap approx. 1 meter away from the outlet in non-insulated pipelines.

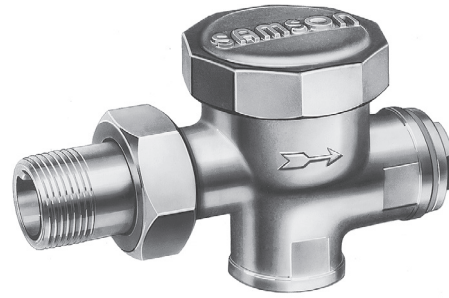
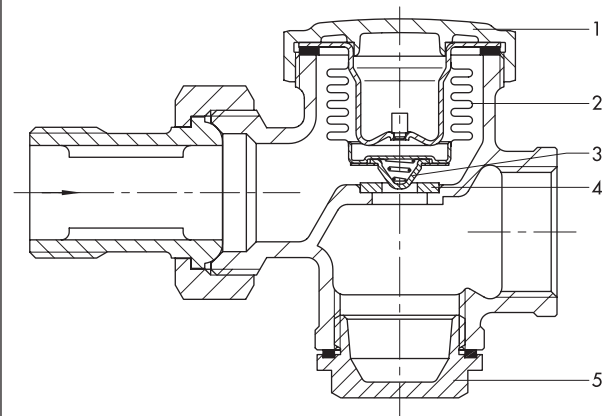

Fig. 4: Type 13 E Steam Trap



- 1 Cover
- 2 Operating element
- 3 Plug
- 4 Seat
- 5 Blanking plug

Fig. 5: Functional diagram of Type 13 E Steam Trap

### Flow diagram

The diagram is based on a condensate temperature of 20 °C. The pressure [bar] is the differential pressure between the inlet and outlet of the steam trap.

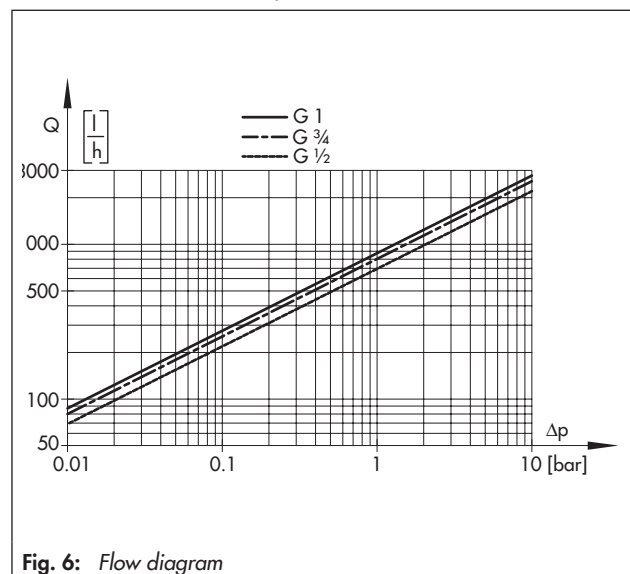

Fig. 6: Flow diagram

**Table 3:** Technical data · All pressure stated as gauge pressure

Type 13 E Steam Trap	
Connecting thread	G ½ · G ¾ · G 1
Operating range	0.01 to 10 bar
Max. permissible temperature	200 °C
Temperature of the discharged condensate	≤ Saturated steam temperature
Max. permissible ambient temperature	40 °C

**Table 4:** Materials · Material numbers according to DIN EN

Body	Malleable iron GTW-35-04 (EN-GJMW-350-4)
Cover/top blanking plug	Malleable iron GTW-35-04 (EN-GJMW-350-4)
Seat	Stainless steel 1.4104
Plug	Stainless steel 1.4101
Operating element	Stainless steel 1.4541

### Dimensions

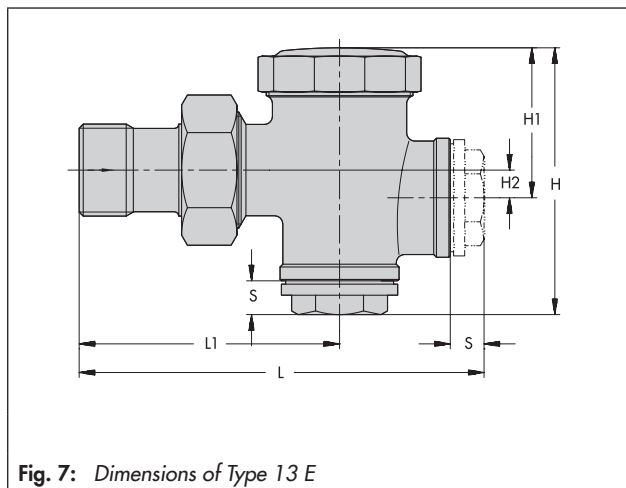

**Table 5:** Dimensions in mm and weight · Type 13 E

Thread size	G ½	G ¾	G 1
L	132	138	151
L1	80	85	95
H	85	90	98
H1	38	40	43
H2	10	10	10
S	12	12	15
Weight, approx. kg	0.8	0.9	1.3

### Ordering text

Type 13 E Steam Trap

G ½, G ¾, G 1 connecting thread

### Typical applications

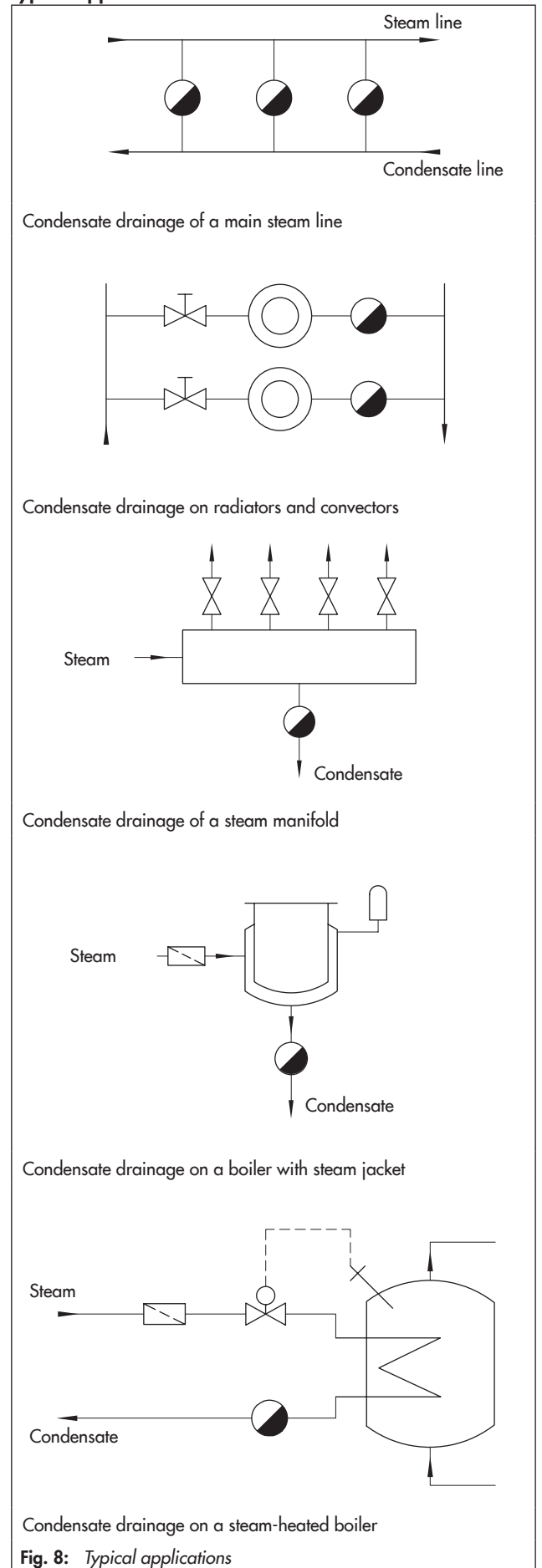

Specifications subject to change without notice



SAMSON AG · MESS- UND REGELTECHNIK  
Weismüllerstraße 3 · 60314 Frankfurt am Main, Germany  
Phone: +49 69 4009-0 · Fax: +49 69 4009-1507  
samson@samson.de · www.samson.de

**T 0500 EN**

2015-02-20 · English