

Type 2422/2424 Pressure Reducing Valve

Application

Pressure regulators for set points from **0.05 to 2.5 bar** · Valve nominal sizes **DN 125 to 250** ¹⁾ · Nominal pressure **PN 16 to 40** · Suitable for liquids, gases and vapors up to **350 °C**

The valve **closes** when the **downstream** pressure **rises**.



The pressure reducing valves, consisting of a valve and an actuator, control the downstream pressure to an adjustable set point. The medium pressure to be kept constant is transmitted through a control line to the diaphragm of the actuator and consequently the valve plug.

Special features

- Low-maintenance, medium-controlled proportional regulators requiring no auxiliary energy
- Wide set point range and convenient set point adjustment using a nut
- Exchangeable set point springs and actuator
- Spring-loaded, single-seated valve with upstream and downstream pressures balanced by a stainless steel bellows or by a balancing diaphragm
- Standard low-noise plug · Special version with flow divider St I or St III for further noise level reduction. See Data Sheet ▶ T 8081.
- Reduced K_{VS} coefficients to adapt the regulator to the operating conditions

Versions

Type 2422/2424 Pressure Reducing Valve for DN 125 to 250

Consisting of:

Type 2422 Valve balanced by a bellows or a diaphragm with soft-seated plug · Body of cast iron, spheroidal graphite iron, cast steel or cast stainless steel · Type 2424 Actuator with EPDM rolling diaphragm

Special versions

- With flow divider St I or St III for particularly low-noise operation
- With metal-seated plug
- With FPM (FKM) rolling diaphragm, e.g. for mineral oils or flammable gases

¹⁾ Valves larger than DN 250 on request

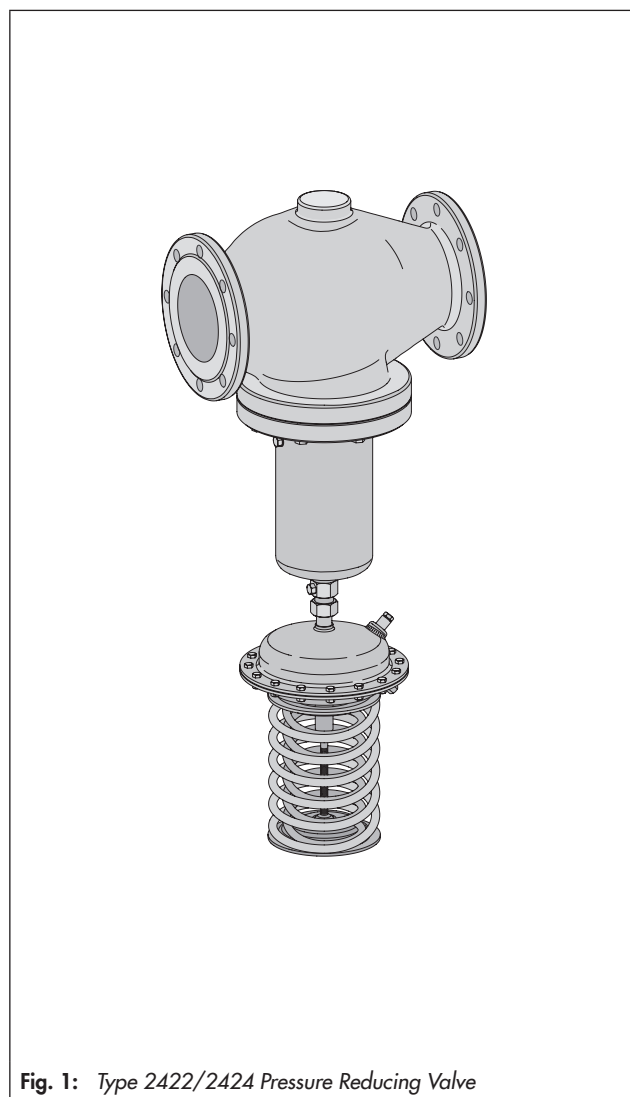

Fig. 1: Type 2422/2424 Pressure Reducing Valve

- With NBR rolling diaphragm for flammable gases
- Version completely in stainless steel for nominal pressure PN 16 to 40 · Details on request
- Actuator with two diaphragms
- With metal cover to protect the set point springs

Principle of operation (see Fig. 2)

The medium flows through the valve in the direction indicated by the arrow. The position of the plug (3) determines the flow rate across the area released between plug (3) and valve seat (2). The plug stem (5) with the plug is connected to the actuator stem (11) of the actuator (10).

The downstream pressure p_2 is regulated by the set point springs (7) and the set point adjuster (6). When relieved of pressure, the valve is opened by the force of the set point springs.

The downstream pressure p_2 to be controlled is tapped downstream of the valve and transmitted over the control line to the operating diaphragm (12) where it is converted into a positioning force. This force is used to move the valve plug (3) according to the force of the set point springs. The spring force is adjustable at the set point adjuster (6). When the force resulting from the downstream pressure p_2 rises above the adjusted pressure set point, the valve closes proportionally to the change in pressure.

The principle of operation of the regulator balanced by a bellows or diaphragm only differs concerning the pressure balancing. The valves balanced by a diaphragm have a balancing diaphragm (4.2) instead of a bellows (4.1). In both cases, the forces created by the upstream and downstream pressures that act on the valve plug are balanced out.

The valves can be supplied with flow divider St I or St III. The valve seat must be replaced on retrofitting the flow divider.

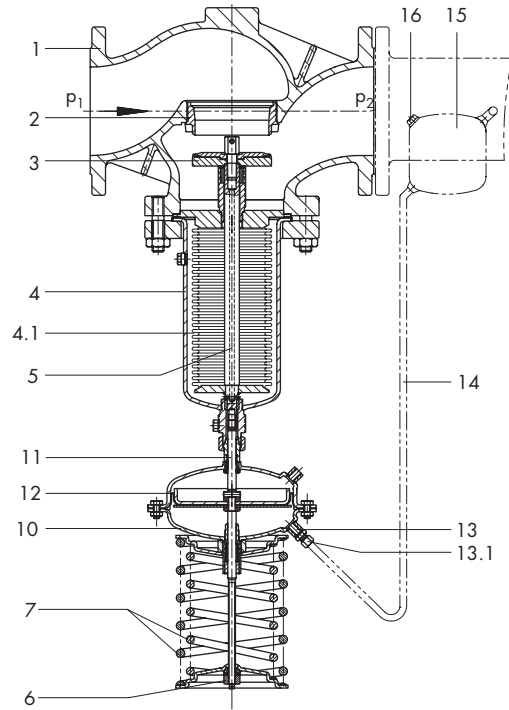

Type 2422/2424 Pressure Reducing Valve
Type 2422 Valve, balanced by a bellows

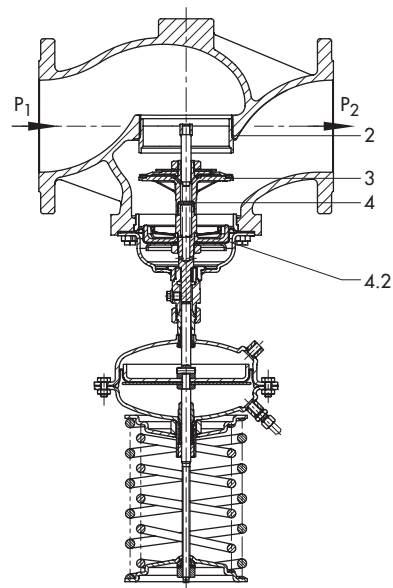

Type 2422/2424 Pressure Reducing Valve
Type 2422 Valve, balanced by a diaphragm

- 1 Valve body
- 2 Seat (exchangeable)
- 3 Plug
- 4 Bellows housing
- 4.1 Balancing bellows
- 4.2 Balancing diaphragm
- 5 Plug stem
- 6 Set point adjuster
- 7 Set point springs
- 10 Actuator
- 11 Actuator stem
- 12 Operating diaphragm
- 13 Control line connection G 1/4
- 13.1 Screw joint with restriction
- 14 Control line (to be mounted on site)
- 15 Compensation chamber
- 16 Filler plug

- p_1 Upstream pressure
- p_2 Downstream pressure

Fig. 2: Functional diagram

Table 1: Technical data · All pressures in bar (gauge)

Type 2422 Valve		DN 125	DN 150	DN 200	DN 250
Nominal size					
Nominal pressure		PN 16, 25 or 40			
Max. permissible temperature	Valve body	See pressure-temperature diagram in ► T 2500			
	Plug balanced by a bellows	Metal seal: 350 °C · PTFE soft seal: 220 °C · EPDM or FPM (FKM) soft seal: 150 °C NBR soft seal: 80 °C			
	Plug balanced by a diaphragm	150 °C			
Leakage class according to IEC 60534-4		≤ 0.05 % of K_{VS} coefficient			
Type 2424 Actuator					
Set point ranges		0.05 to 0.25 bar · 0.1 to 0.6 bar · 0.2 to 1 bar · 0.5 to 1.5 bar · 1 to 2.5 bar ¹⁾			
Max. perm. pressure at actuator	Actuator area	320 cm ²		640 cm ²	
	Pressure	3 bar		1.5 bar	
Max. permissible temperature		Gases at the actuator 80 °C · Liquids 150 °C, with compensation chamber 350 °C Steam with compensation chamber 350 °C			

¹⁾ Set point ranges above 2.5 bar, see ► T 2552 (Type 2333 Pressure Reducing Valve)

Table 2: Materials · Material numbers according to DIN EN

Type 2422 Valve, balanced by a bellows				
Nominal pressure	PN 16	PN 25	PN 16, 25 and 40	
Valve body	Cast iron EN-GJL-250	Spheroidal graphite iron EN-GJS-400-18-LT	Cast steel 1.0619	Stainless steel 1.4408
Seat	1.4006			1.4404
Plug	1.4404			1.4404 with PTFE seal
Seal for soft-seated plug	PTFE · EPDM · FPM (FKM) · NBR			
Plug stem	1.4301			
Metal bellows	1.4571			
Bottom section	1.0305			1.4571
Body gasket	Graphite on metal core			
Type 2422 Valve, balanced by a diaphragm				
Nominal pressure	PN 16	PN 16/25	PN 16, 25 and 40	
Valve body	Cast iron EN-GJL-250	Spheroidal graphite iron EN-GJS-400-18-LT	Cast steel 1.0619	Stainless steel 1.4408
Valve seat	Red brass ¹⁾			
Plug	Standard version Red brass ¹⁾ · With EPDM soft seal or with PTFE soft seal			
Pressure balancing	Balancing cases made of sheet steel DD11 · EPDM balancing diaphragm for liquids and non-flammable gases or NBR diaphragm for flammable gases			
Gasket	Graphite on metal core			
Type 2424 Actuator				
Diaphragm cases	DD 11			1.4301
Diaphragm	EPDM with fabric reinforcement · FPM (FKM) · NBR			
Guide bushing	DU bushing			PTFE
Seals	EPDM · FPM (FKM) · NBR			

¹⁾ Special version: 1.4409

Table 3: Valve balanced by a bellows · K_{VS} coefficients and max. perm. differential pressures Δp

Type 2422 Valve, balanced by a bellows				
K _{VS} coefficients and max. permissible differential pressures Δp				
DN	Standard K _{VS} coefficients	Flow divider St I · K _{VS} I	Flow divider St III · K _{VS} III	Max. perm. differential pressure Δp
125	190	150	95	16 bar
150	280	210	140	12 bar
200	420	315	200	10 bar
250	500	375	220	10 bar
Reduced K _{VS} coefficients and max. permissible differential pressures Δp				
125	80	60	40	20 bar
150	125	95	60	16 bar
200	280	210	140	12 bar
250	280	210	140	12 bar

Table 3.1: Valve balanced by a diaphragm · K_{VS} coefficients and max. perm. differential pressures Δp

Type 2422 Valve, balanced by a diaphragm				
K_{VS} coefficients and max. permissible differential pressures Δp				
Nominal size	DN 125	DN 150	DN 200	DN 250
K_{VS} coefficient	250	380	650	800
Max. perm. differential pressure Δp	12 bar		10 bar	

Dimensions

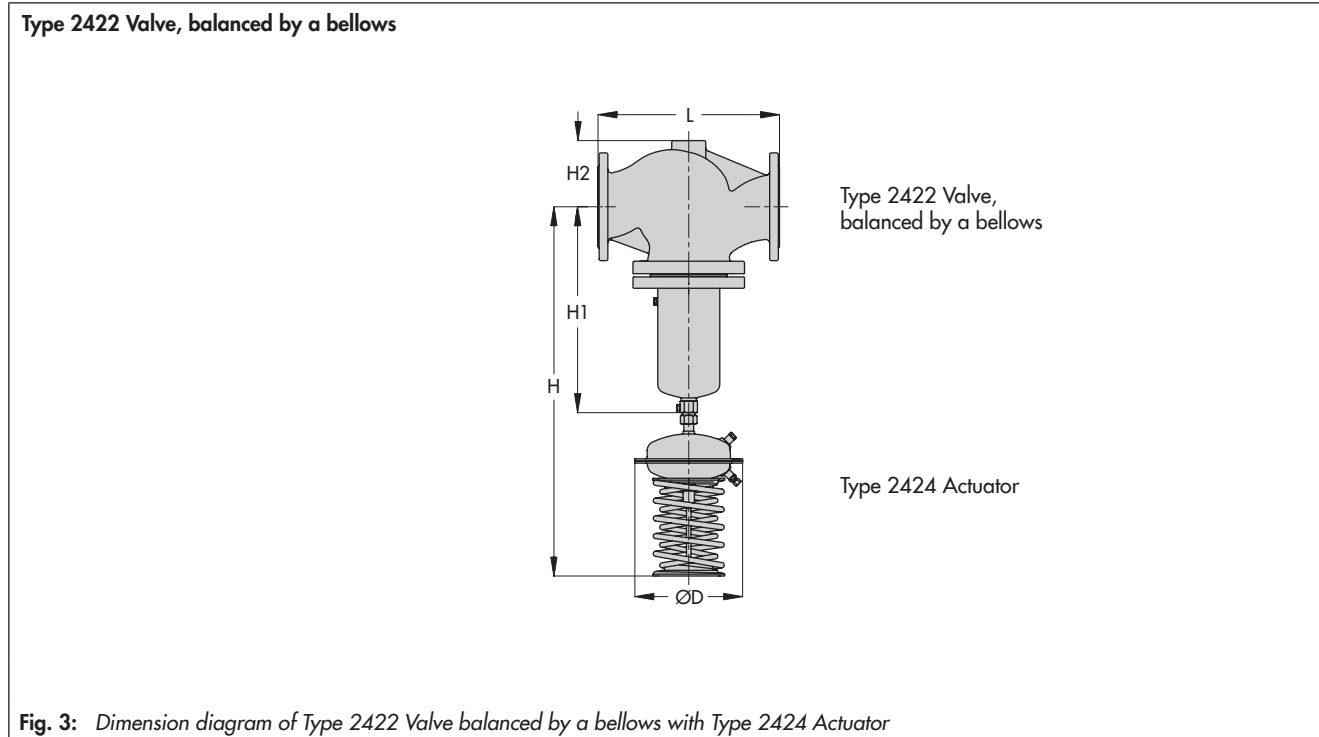

Fig. 3: Dimension diagram of Type 2422 Valve balanced by a bellows with Type 2424 Actuator

Table 4: Dimensions in mm and weights · The values in parentheses apply to temperatures from 220 to 350 °C · **Valve balanced by a bellows**

Nominal size		DN 125	DN 150	DN 200	DN 250
Valve dimensions	Length L	400	480	600	730
	Height H1	460 (600)	590 (730)	730 (870)	
	Height H2	145	175	270	
Set points	Valve with actuator				
0.05 to 0.25 bar	Height H	990 (1130)	1120 (1260)	1260 (1400)	
	Actuator	ØD = 390 mm, A = 640 cm ²			
0.1 to 0.6 bar	Height H	990 (1130)	1120 (1260)	1260 (1400)	
	Actuator	ØD = 390 mm, A = 640 cm ²			
0.2 to 1.0 bar	Height H	990 (1130)	1120 (1260)	1260 (1400)	
	Actuator	ØD = 390 mm, A = 640 cm ²			
0.5 to 1.5 bar	Height H	910 (1050)	1040 (1180)	1180 (1320)	
	Actuator	ØD = 285 mm, A = 320 cm ²			
1 to 2.5 bar	Height H	910	1040	1180	
	Actuator	ØD = 285 mm, A = 320 cm ²			
Weight ¹⁾ , approx.		91 kg	134 kg	276 kg	321 kg

¹⁾ The weight applies to the version with the material specifications EN-GJL-250/PN 16. Add +10 % for all other materials.

Type 2422 Valve, balanced by a diaphragm

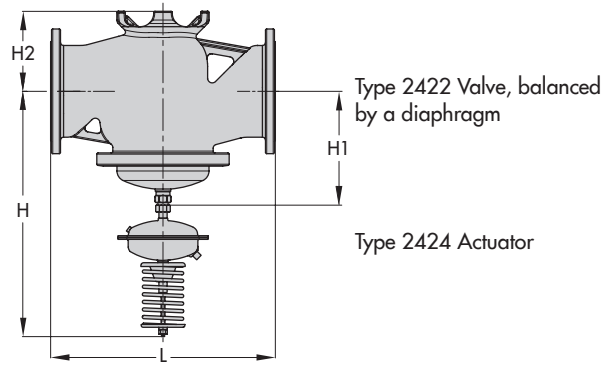

Fig. 4: Dimension drawing of Type 2422 Valve balanced by a diaphragm with Type 2424 Actuator

Table 5: Dimensions in mm and weights · Valve balanced by a diaphragm

Nominal size		DN 125	DN 150	DN 200	DN 250
Length L		400	480	600	730
Height H1		285	310	380	
Height H2		145	175	260	
Set points	Valve with actuator				
0.05 to 0.25 bar	Height H	815	840	910	
	Actuator	ØD = 390 mm · A = 640 cm ²			
0.1 to 0.6 bar	Height H	815	840	910	
	Actuator	ØD = 390 mm · A = 640 cm ²			
0.2 to 1 bar	Height H	735	760	830	
	Actuator	ØD = 285 mm · A = 320 cm ² ¹⁾			
0.5 to 1.5 bar	Height H	735	760	830	
	Actuator	ØD = 285 mm · A = 320 cm ² ¹⁾			
1 to 2.5 bar	Height H	735	760	830	
	Actuator	ØD = 225 mm · A = 320 cm ²			
Weight ²⁾ , approx.		75 kg	95 kg	250 kg	270 kg

¹⁾ Optionally with 640 cm² actuator

²⁾ The weight applies to the version with the material specifications EN-GJL-250/PN 16. Add +10 % for all other materials.

Installation

- Install valves with the actuator suspended downward.
- Install pipelines horizontally with a slight downward slope on both sides of the valve to prevent condensed water from collecting.
- The direction of flow must match the direction indicated by the arrow on the body.
- Connect a control line to the actuator from the point of pressure tapping located approx. 1 m downstream of the valve in the pipe wall or at the point of measurement of the connected plant (with compensation chamber, if applicable).

Accessories

- Screw joints with restriction for connection of the control line (e.g. 6 or 12 mm pipe).
- Only applicable to valves balanced by a bellows: compensation chamber for condensation and to protect the operating diaphragm against extreme temperatures. The chamber is required for steam and liquids above 150 °C.

For detailed information on accessories refer to Data Sheet

▶ T 2595

Ordering text

Type 2422/2424 Pressure Reducing Valve

DN ...

Body material ..., PN ...

K_{V5} coefficient ..., set point range ... bar

Balanced by a bellows or diaphragm

Optionally, special version ..., accessories ...

Specifications subject to change without notice



SAMSON AG · MESS- UND REGELTECHNIK
Weismüllerstraße 3 · 60314 Frankfurt am Main, Germany
Phone: +49 69 4009-0 · Fax: +49 69 4009-1507
samson@samson.de · www.samson.de

T 2547 EN

2016-09-09 · English