

Type 50 EM Pressure Reducing Valve

Application

Pressure regulator for set points from **0.2 to 10 bar** · Valves **G 3/8** and **G 1/2** · Nominal pressure **PN 16** · Suitable for **water** and other **liquids, air** and **non-flammable gases** up to **50 °C**

The valve closes when the downstream pressure rises.

The regulator consists of a valve, a spring-loaded operating diaphragm and a set point adjuster.

Special features

- Low-maintenance proportional regulators requiring no auxiliary energy
- Wide set point range and convenient set point adjustment
- Tight-closing, spring-loaded, single-seated valve, which can be used for upstream pressures up to 16 bar
- Suitable for media that do not affect the operating diaphragm and do not cause the materials used to corrode

Versions

Type 50 EM · (Fig. 1) Pressure reducing valve with connection for a pressure gauge (Ø 63 mm housing, G 1/4 connection) to indicate the downstream pressure.

Accessories · Pressure gauge with G 1/4 connection, Ø 63 mm housing, scale division 0 to 4 bar, 0 to 6 bar or 0 to 16 bar

Table 1: Technical data · All pressures in bar (gauge)

Type	50 EM	
Thread size	G 3/8	G 1/2
K _{V5} coefficient	0.93	
Max. permissible upstream pressure	16 bar	
Max. permissible temperature	50 °C	
Set point range in bar	Continuously adjustable: 0.2 to 4, 2.5 to 6 or 4 to 10	
Materials · Material numbers according to DIN EN		
Body, seat	CW617N (brass)	
Plug	Stainless steel 1.4104 with NBR soft seal	
Diaphragm	CR (chloroprene rubber)	



Fig. 1: Options for pressure gauge attachment with Type 50 EM

Principle of operation

The plug connection link (6) connects the operating diaphragm (4) and the valve plug (8). The downstream pressure to be maintained at a constant pressure produces a force on the operating diaphragm (4), which is used to adjust the valve plug (8) as a function of the adjusted set point.

Installation

- The valve can be mounted in any desired position.
- Direction of flow must match the direction indicated by the arrow on the body

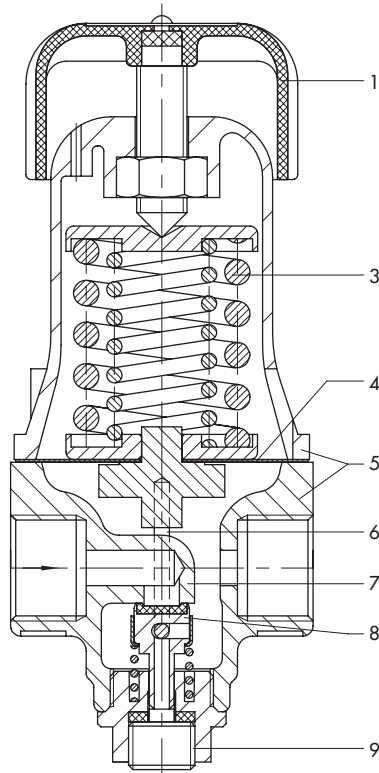

- 1 Set point adjuster
- 2 Compression spring
- 4 Operating diaphragm
- 5 Body
- 6 Plug connection link
- 7 Seat
- 8 Valve plug with soft seal
- 9 Connection for pressure gauge

Fig. 2: Functional diagram of Type 50 EM Pressure Reducing Valve

Table of dimensions

Table 2: Dimensions in mm

Type	50 EM	
	G 3/8	G 1/2
Thread size	G 3/8	G 1/2
Length L	60	
Height H1	113	
Height H2	37	
Weight, approx.	0.7 kg	

Ordering text

Type 50 EM Pressure Reducing Valve

Thread size G ..., set point range ... bar

Pressure gauge Ø 63 mm, G 1/4

- 0 to 4 bar Order no.: 8520-0111
- 0 to 6 bar Order no.: 8520-0119
- 0 to 16 bar Order no.: 8520-0134

Optionally, accessories ...

Specifications subject to change without notice

Dimensions

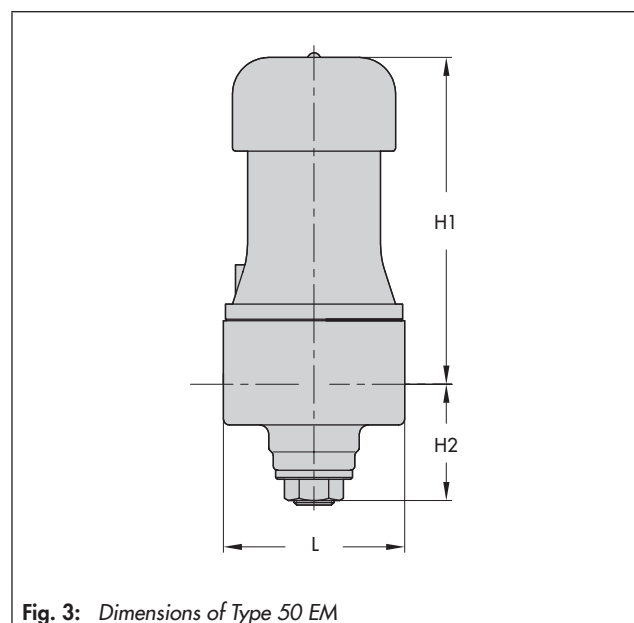

Fig. 3: Dimensions of Type 50 EM

