



Type 7316 Dual-channel Emergency Shutdown System

Application

To protect a downstream network or plant against excessively high or excessively low pressures or temperatures

Special features

- SIL 2/SIL 3

General SIL solutions

Our emergency shutdown systems include single-channel solutions for SIL 2 applications and dual-channel solutions for applications up to SIL 3.

SAMSON's safety-instrumented systems consist of one SAMSON on/off valve (single-channel) or two SAMSON on/off valves (dual-channel), a SAMSON SIS logic solver and the application-specific sensor instrumentation.

All SAMSON SIL solutions use components that are perfectly tailored to one another. The safety integrity level of the safety-instrumented system (including all the PFD values) is documented in a manufacturer's declaration.

Application range

SAMSON safety-instrumented systems are designed exclusively for **low demand mode**. SAMSON emergency shutdown systems are available with a probability of failure (PFD_{AVG}) to meet SIL 2 or SIL 3 requirements.

Application

The Type 7315 Single-channel Emergency Shutdown System (SIL 2) and Type 7316 Dual-channel Emergency Shutdown System (SIL 3) protect a downstream network, plant or heat exchanger etc. against excessively high or excessively low pressures or temperatures.

Backflow protection units monitor the medium flow by measuring the differential pressure across the valve assembly unit. The Type 7305 Backflow Protection Unit is used for dual-channel systems (SIL 3) and the Type 7301 Backflow Protection Unit for single-channel systems (SIL 2).

Version

Type 7316 Dual-channel Emergency Shutdown System

The dual-channel emergency shutdown system protects a downstream network, plant or heat exchanger etc. against excessively high or excessively low pressures or temperatures. If the temperature or pressure exceeds or falls below a certain limit, the emergency shutdown system is triggered. The use of one of the shut-off valves as a control valve is permitted. The reliability is indicated in the risk analysis of the plant in which it is installed.

Design and function

The Type 7316 Dual-channel Emergency Shutdown System consists of two shut-off valves (Pos. 01 A+B), two pressure/temperature sensors (Pos. 02 A+B) and the Type 7402 SIS Logic Solver (Pos. 03).

The pressure/temperature sensors (Pos. 02 A+B) transmit the signals to the Type 7402 SIS Logic Solver. The signals are analyzed by the SIS logic solver. The shut-off valves are closed in the safety-instrumented system when the temperature/pressure exceeds or falls below the corresponding set point.

Signals to indicate the safety demand, status and malfunction of the SIS logic solver can be transmitted to a higher-level control system. These signals are optional since the control system works independently.

An optional bleed function can be added to the Type 7316 Dual-channel Emergency Shutdown System. It ensures that any leakage through the valve is safely discharged to another location. As a result, the overall system meets the strictest safety requirements.

The Type 7316 Dual-channel Emergency Shutdown System can optionally be constructed for use in hazardous areas. The SIS logic solver must always be installed outside the hazardous area.

Any component not shown in Fig. 2 is not part of the SIS loop.

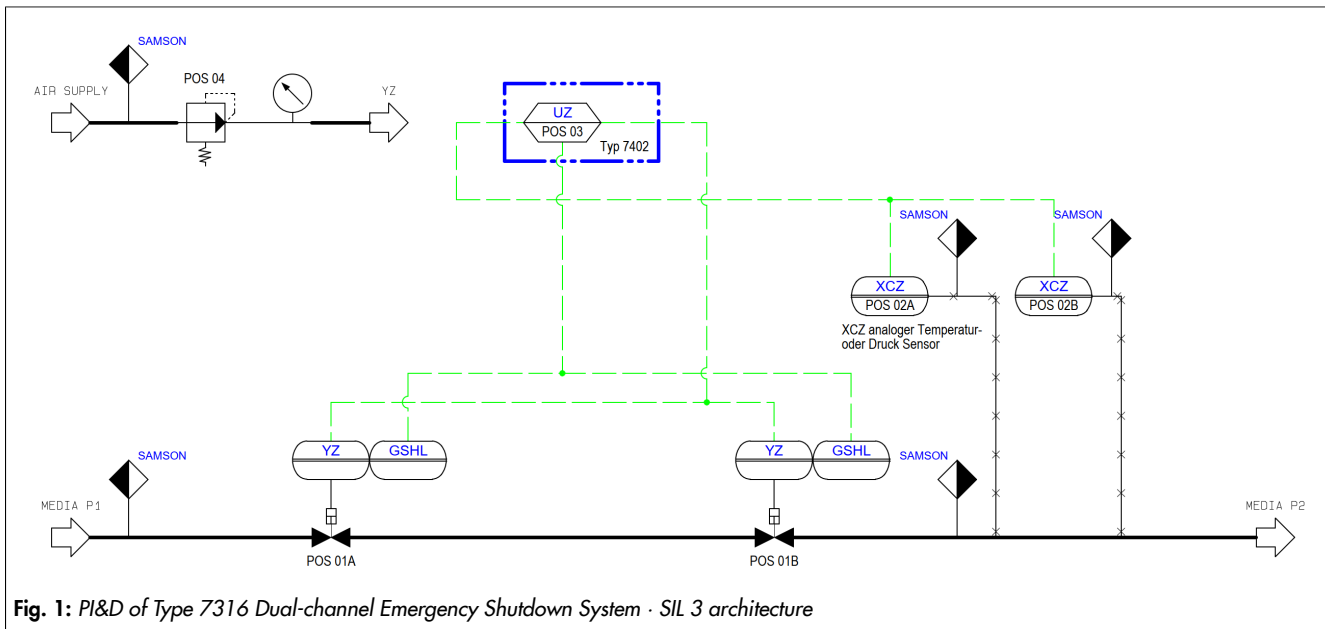

Fig. 1: PI&D of Type 7316 Dual-channel Emergency Shutdown System · SIL 3 architecture

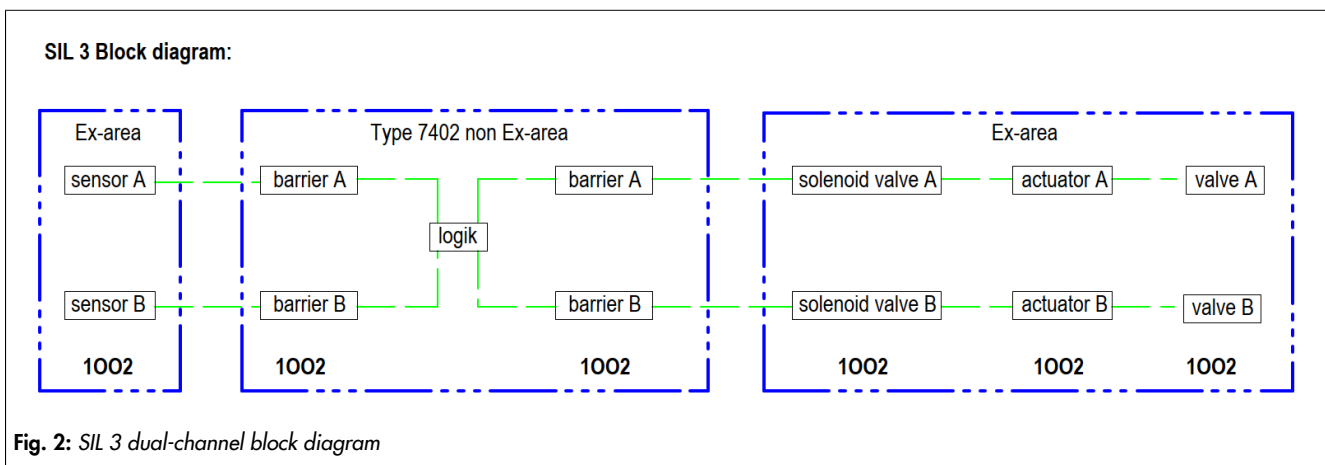

Fig. 2: SIL 3 dual-channel block diagram

Table 1: Components

Item	Designation	Types
01 A/B	Valve body	e.g. Type 3241, Type 3251, Type 3510, Type 26d, Type 14
	Actuator	e.g. Type 3271, Type 3277, Type 31a
02 A+B	Sensor (pressure)	E+H Type PMP71B ABB Type 266 GST/AST Labom Type PASCAL CI4
	Sensor (temperature)	Jumo Type 902006/2x Pt100
03		Type 7402 SIS Logic Solver
04		Type 4708/Type 3999 Supply Air Station

Table 2: Technical data

Dual-channel emergency shutdown system	Type 7316 ¹⁾
Safety integrity level	SIL 3/SIL 2
Medium	Gases and liquids according to the data sheets for Type 3241 Valve (▶T 8015)/ Type 3251 Valve (▶T 8051)/Type 26d Valve (▶T 26d) and Type 14b Valve (▶T 14b). Special applications on request
Nominal size	DN 15 to 500 (larger nominal sizes on request)
Pressure rating	PN 16 to 400 (higher pressure ratings on request)
Standards	DIN EN 61508; DIN EN 61511; PED
Bleed function	Optional
Supply	24 V DC/instrument air according to ISO 8573-1
Feedback signal to meet SIL requirements	1x floating contact

¹⁾ Special versions on agreement

Type 7316 Dual-channel Emergency Shutdown System

Customer data			
Company			
Address			
Name			
Phone number			
E-mail			
Send your inquiry to your regional SAMSON contact or e-mail it to ► systems-de@samsongroup.com.			
Operating data			
Nominal size/pressure rating	DN PN		
Instrument air	bar(g)		
Process medium	Process medium = $T_{max} =$ °C $P_{max} =$ bar(g)		
Min. flow rate ¹⁾	kg/h Nm³/h (gases)		
Max. flow rate ¹⁾	kg/h Nm³/h (gases)		
Flow rate during operation	kg/h Nm³/h (gases)		
Operating pressure	$P_1 =$ bar(g) (pressure upstream of the backflow protection unit)		
Material	Pipeline Valve body		
Version	✓ According to SAMSON standard With control function (version according to SAMSON standard with Type 3730 Positioner) Without control function		
SIS logic solver	✓ SAMSON Type 7402 (indoor installation) Outdoor installation		
Terminal box	✓ According to SAMSON standard to connect SIS logic solver in hazardous areas		
Valve type	✓ Sized by SAMSON		
SIL probability of failure	✓ According to SAMSON manufacturer's declaration (overall system)		
Sensor	<table style="width: 100%; border: none;"> <tr> <td style="width: 50%; vertical-align: top;">Pressure sensor E+H PMP71B ABB 266GST/AST Labom PASCAL C14</td> <td style="width: 50%; vertical-align: top;">Temperature sensor Jumo 902006/2x Pt100</td> </tr> </table>	Pressure sensor E+H PMP71B ABB 266GST/AST Labom PASCAL C14	Temperature sensor Jumo 902006/2x Pt100
Pressure sensor E+H PMP71B ABB 266GST/AST Labom PASCAL C14	Temperature sensor Jumo 902006/2x Pt100		
SIL	SIL 2 = Version with one sensor ✓ SIL 3		
ATEX	Without Up to Zone 1 (intrinsically safe)		
Bleed function	✓ Without With bleed function DN 25 (valve selected by SAMSON)		
Notes			

¹⁾ Specification required when a valve with control function is selected