

Series 240

Type 3241-1 and Type 3241-7

Pneumatic Control Valves with safety function



Tested according to DIN EN 14597

Application

Control valves for water and steam with safety function to protect heating systems against excess temperatures or pressures

Nominal size DN 15 to 150

Nom. pressure PN 16 to 40

Temperatures Suitable for water and steam up to 350 °C



The control valve (tested according to DIN EN 14597) consists of a Type 3241 Globe Valve with

- Type 3271 Pneumatic Actuator and a solenoid valve (Type 3241-1 Control Valve)
- Type 3277 Pneumatic Actuator and a solenoid valve (Type 3241-7 Control Valve)

Valve body made of

- Cast iron
- Spheroidal graphite iron
- Cast steel or cast stainless steel
- Forged steel or forged stainless steel

Special features

- Undivided valve bonnet
- Metal-seated valve plug

The control valves regulate the temperature downstream of a pneumatic or electric controller. In safety interlock circuits, they also serve as a shut-off device that is triggered upon a power failure or by the signal of a temperature or pressure limiting device.

The control valves are tested by the German Technical Inspectorate (TÜV) according to DIN EN 14597 and have been defined as shut-off and control devices. The standard version of the valve is suitable for water and steam up to 220 °C and the version with an insulating section up to 350 °C at operating pressures listed in Technical data (Table 1) and at a maximum permissible ambient temperature of 50 °C. In safety circuits, a strainer (e.g. Type 2 NI according to Data Sheet ▶ T 1015) must be installed in the direction of flow upstream of the control valve.

The control valves, designed according to the modular assembly principle, can be equipped with various accessories:

Positioners, limit switches according to IEC 60534-6-1 and NAMUR recommendation. Details in Information Sheet ▶ T 8350.



Fig. 1: Type 3241-1 Pneumatic Control Valve (tested by TÜV according to DIN EN 14597) with Type 3701 Solenoid Valve

Versions

Standard version designed for temperatures from -10 to 220 °C with pneumatic actuator and Type 3701, Type 3963 or Type 449 Solenoid Valve

- **Type 3241-1** (Fig. 1) · Valve with Type 3271 Pneumatic Actuator · (see Data Sheet ▶ T 8310-1)
- **Type 3241-7** · Valve and Type 3277 Pneumatic Actuator for integral positioner attachment (see Data Sheet ▶ T 8310-1)

Further versions

- **Flow divider** for noise reduction · See Data Sheet ▶ T 8081
- **Insulating section** · For medium temperatures up to 350 °C
- **Balanced valve plug with PTFE ring** · See Table 3.2

Also available:

- **Electric control valve with safety function** · See Data Sheet ▶ T 5871
- **DIN/DVGW tested version for gas** · See Data Sheet ▶ T 8020

Principle of operation (Fig. 2 and Fig. 3)

In control operation, the signal pressure p_{st} controlled either by a temperature controller or positioner is applied to the actuator.

If the power fails or the safety limiting device interrupts the control current when the temperature or pressure limits are exceeded, the solenoid valve switches back to the idle position. As a result, the supply pressure line is shut off, the actuator is vented and the force of the actuator springs closes the valve.

Register number

The Type 3241 Globe Valves have been tested by TÜV (German Technical Inspectorate) in combination with the Type 3271 and Type 3277 Pneumatic Actuators (register number available on request).

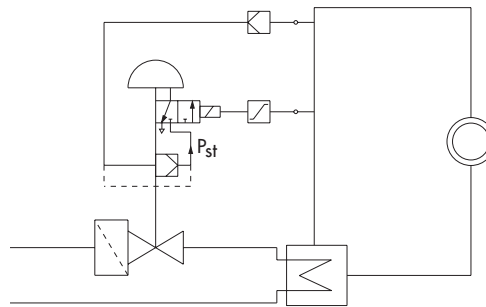

Fig. 2: Connection diagram for pneumatic positioner with safety function

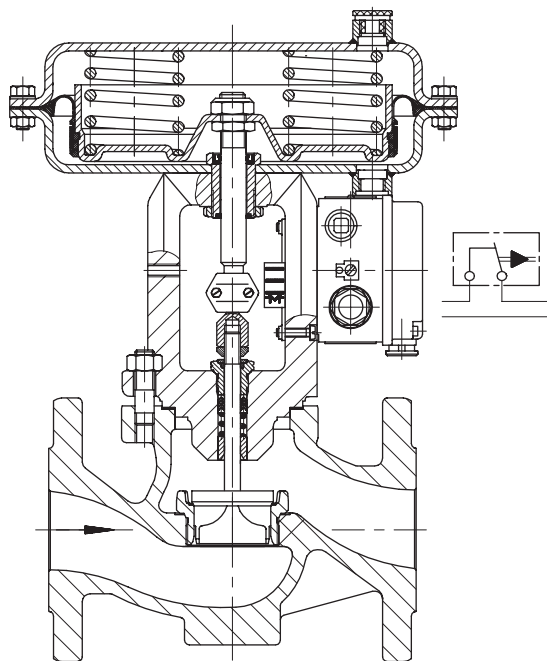

Fig. 3: Type 3241-1 Control Valve (tested according to DIN EN 14597)

Table 1: Technical data · For further technical data, see Data Sheet ▶ T 8015

Nominal size	DN 15 to 150					
Material	Cast iron ¹⁾ EN-GJL-250 (EN-JL1040)/ A126 B	Spheroidal graphite iron EN-GJS-400- 18-LT (EN-JS1049)/ A 95	Cast steel 1.0619/ A216 WCC	Forged steel 1.0460/A 105	Cast stainless steel 1.4581	Forged stainless steel 1.4571
Nominal pressure PN	16	16 · 25	16 · 40		40	40
Differential pressures Δp	See Table 3 for permissible differential pressures					
Type of end connections	Flanges and welding ends according to DIN and ANSI					
Seat/plug seal	Metal seal					
Characteristic	Equal percentage · Linear · Quick opening					
Closing time	<5 s with limiting function					
Compliance	CE · EAC					
Maximum medium temperature in °C · Permissible operating pressures according to pressure-temperature diagrams (see Information Sheet ▶ T 8000-2)						
Body without insulating section	220 °C · Also applies to pressure balancing with PTFE ring					
Body with insulating section	300 °C	350 °C	350 °C	350 °C	350 °C	350 °C
Leakage class according to IEC 60534-4	Class IV					

¹⁾ With hot water only up to DN 50; in plants conforming to TRD (German technical rules for steam boilers): max. perm. operating pressure 10 bar; in plants conforming to TRB (German technical rules for pressure vessels) up to PN 16 permissible.

Solenoid valve	Type 3701		Type 3963	
Degree of protection	–	Intrinsically safe ⊕ II 2 G Ex ia IIC T6 Non-sparking ⊕ II 3 G Ex nA II T6	–	Intrinsically safe ⊕ II 2 G Ex ia IIC T6 Non-sparking ⊕ II 3 G Ex nA II T6
Power supply and power consumption	24 V/50 Hz 230 V/50 Hz both 150 mW	7.5 V DC, 20 mW 24 V DC, 150 mW	24 V/50 Hz 230 V/50 Hz both 150 mW	7.5 V DC, 20 mW 24 V DC, 150 mW

Table 2: K_{VS} coefficientsTerms for control valve sizing according to IEC 60534, Parts 2-1 and 2-2: $F_L = 0.95$, $X_T = 0.75$ **Table 2.1:** Overview with flow divider ST 1 (K_{VS1}) and ST 3 (K_{VS3})

K_{VS}	0.1 0.16 0.25	0.4	0.63	1.0	1.6	2.5	4.0	6.3	10	16	25	40	60	80	63	100	160	200	260
K_{VS1}	-			1.45	2.2	3.6	5.7	9	14.5	22	36	54	72	57	90	144	180	234	
K_{VS3}	-								7.5	-	20	30	-	-	47	75	120	-	-
Seat \varnothing [mm]	3	6		12			24		31	38	48	63	80	63	80	100	110	130	
Rated travel [mm]	15												30				30		

Table 2.2: Versions without flow divider · Areas highlighted in gray indicate versions also with pressure balancing

K_{VS}	0.1 0.16 0.25	0.4	0.63	1.0	1.6	2.5	4.0	6.3	10	16	25	40	60	80	63	100	160	200	260
DN																			
15	•	•	•	•	•	•	•												
20	•	•	•	•	•	•	•	•											
25	•	•	•	•	•	•	•	•	•										
32		•	•	•	•	•	•	•	•	•									
40		•	•	•	•	•	•	•	•	•	•								
50		•	•	•	•	•	•	•	•	•	•	•							
65											•	•	•						
80											•	•	•	•					
100															•	•	•		
125																•		•	
150																	•		•

Table 2.3: Versions with flow divider ST 1 (K_{VS1}) · Areas highlighted in gray indicate versions also with pressure balancing

K_{VS1}	-			1.45	2.2	3.6	5.7	9	14.5	22	36	54	72	57	90	144	180	234	
DN																			
32							•	•	•										
40							•	•	•	•									
50							•	•	•	•	•								
65											•	•	•						
80											•	•	•	•					
100															•	•	•		
125																•		•	
150																	•		•

Table 2.4: Versions with flow divider ST 3 (K_{VS3}) · Areas highlighted in gray indicate versions also with pressure balancing

K_{VS3}	-								7.5	-	20	30	-	-	47	75	120	-	-
DN																			
50									•										
65											•								
80												•							
100															•				
125																•			
150																	•		

Table 3: Differential pressures in bar (further information in Notes on differential pressure table)**Table 3.1:** Valves with balanced metal-seated plugs

Values specified in shaded columns apply to standard cases · Differential pressures specified in white columns apply to maximum pretensioned springs · Values in parentheses apply to half travel

Bench range [bar] with actuator area [cm ²]		240	0.2 to 1.0	–	0.4 to 2.0	0.6 to 2.2	–	–	–
		350, 700		0.4 to 1.2		–	0.8 to 2.4	1.4 to 2.3	
		700			(1.2 to 2.0)	–	(1.6 to 2.4)	(1.85 to 2.3)	2.0 to 3.2 ¹⁾
Required supply pressure			1.2	1.4	2.2	2.4	2.6	2.5	3.4
DN	K _{VS}	Actuator area [cm ²]	Δp when p ₂ = 0 bar						
15 to 25	0.1 to 0.25	240	40	–	40	40	–	–	–
15 to 50	0.4 to 1.0	240	20	–	40	40	–	–	–
	1.6	240	27.5	–	40	40	–	–	–
	2.5 4.0	350	40	40	40	–	40	–	–
20 to 50	6.3 · 10	240	5.2	–	14.8	24.5	–	–	–
		350	9.6	24	24	–	40	40	–
		700	–	–	(40)	–	(40)	–	–
32 to 50	16	240	2.5	–	8.3	14.1	–	–	–
		350	5.2	13.6	13.6	–	30	40	–
		700	–	–	(40)	–	(40)	–	–
40 to 80	25	240	1.3	–	5.1	9.0	–	–	–
		350	3.1	8.7	8.7	–	19.9	37	–
		700	–	–	(40)	–	(40)	(40)	–
50 to 80	40	240	–	–	2.9	5.3	–	–	–
		350	–	5.1	5.1	–	12.0	23	–
		700	–	–	(40)	–	(40)	(40)	–
65 80	60	240	–	–	–	2.8	–	–	–
		350	–	2.7	2.7	–	6.7	12	–
		700	–	–	(23)	–	(31)	(36)	–
80	80	240	–	–	–	–	–	–	–
		350	–	1.4	1.4	–	4.0	8.0	–
		700	–	–	(14.1)	–	(19.2)	(22)	–
100	63	700	2.6	6.6	6.6	14.8	–	27	39
	80		1.4	3.9	3.9	9.0	–	16.5	24
	160		–	2.3	2.3	5.6	–	10.5	15.3
125	100	700	1.4	3.9	3.9	9.0	–	16.5	24
	200		–	1.9	1.9	4.5	–	8.5	12.6
150	160	700	–	2.3	2.3	5.6	–	10.5	15.3
	260		0.3	1.2	1.2	3.0	–	6.0	8.9

¹⁾ 2.1 to 3.3 bar bench range relieved to 2.0 to 3.2 bar.

Table 3.2: Valves with balanced plug with PTFE ring · Medium temperature up to 220 °C

Bench range		bar	0.4 to 1.2	0.4 to 2.0	0.8 to 2.4
Required supply pressure		bar	1.4	2.2	2.6
DN	K _{VS}	Actuator	p and Δp		
100	100 · 160	700 cm ²	40	40	40
125	100 · 200				
150	160 · 260				

Table 4: Dimensions in mm for standard versions of Type 3241-1 and Type 3241-7**Table 4.1:** Type 3241 Valve

Valve	DN	15	20	25	32	40	50	65	80	100	125	150
Length L	mm	130	150	160	180	200	230	290	310	350	400	480
H1	≤700 cm ²	220						260		350	363	390
H2	Cast version	44			72			98		118	148	175
	Forged steel	53	–	70	–	92	98	–	128	–		

Table 4.2: Type 3271 and Type 3277 Pneumatic Actuators

Actuator area	cm ²	240	350	700
Diaphragm ØD	mm	240	280	390
H ¹⁾	mm	62	82	199
H3 ²⁾	mm	110	110	190
H5	Type 3277 mm	101	101	101
Thread	Type 3271	M30 x 1.5		
	Type 3277	M30 x 1.5		
α	Type 3271	G ¼ (¼ NPT)	G ⅜ (⅜ NPT)	G ⅝ (⅝ NPT)
α2	Type 3277	G ⅜	G ⅜	G ⅜

¹⁾ Height with welded-on lifting eyelet or height of eyebolt according to DIN 580. Height of the swivel lifting hook may differ. Actuators up to 355 cm² without lifting eyelet

²⁾ Minimum clearance required to remove the actuator

Table 5: Weights in kg for standard version of Type 3241-1 and Type 3241-7**Table 5.1:** Type 3241 Valve

Valve	DN	15	20	25	32	40	50	65	80	100	125	150
Weight without actuator [kg]		5	6	7	11	12	15	24	30	42	80	120

Table 5.2: Type 3271 and Type 3277 Pneumatic Actuators

Actuator	cm ²	240	350	700
Type 3271		5	8	22
	With handwheel	9	13	27
Type 3277		9	12	26
	With handwheel	13	17	31

Table 6: Dimensions in mm and weights in kg for Type 3241 Valve with insulating section · Without actuator

Valve	DN	15	20	25	32	40	50	65	80	100	125	150
Height H4		408			408			450		635	644	671
Weight [kg]		8	9	10	17	18	21	32	38	60	105	150

Dimensional drawings

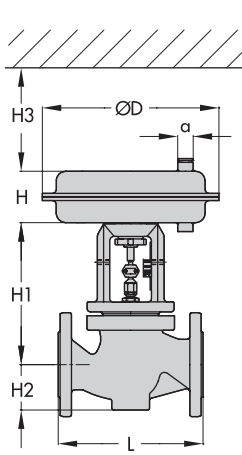

Type 3241-1 with Type 3271 Actuator

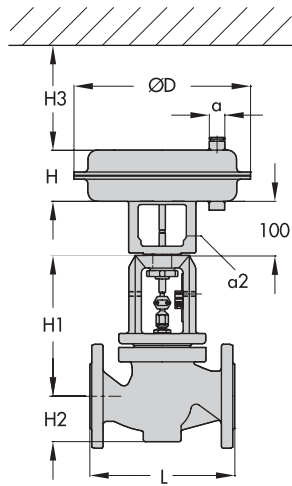

Type 3241-7 with Type 3277 Actuator

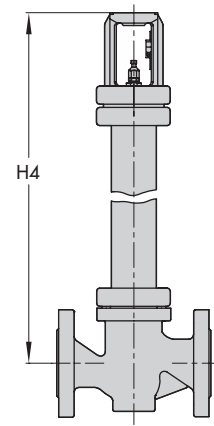

Type 3241 with insulating section

Notes on differential pressure table

The differential pressure tables (Table 3) have been prepared under the following conditions:

- Version with PTFE packing
- Process medium in flow-to-open direction
- Valve closed with 0 bar signal pressure
- The maximum permissible supply pressure is 4 bar for valves in nominal sizes DN 15 to 80 and actuators with an effective diaphragm area of 700 cm²
- The leakage rates specified in Table 1 are not exceeded with the maximum differential pressures specified.
- The permissible operating pressures are restricted by the values specified in the Information Sheet ► T 8000-2 (materials and pressure-temperature diagrams).
- Only on/off valves and versions for 0.2 to 1.0 bar and 0.4 to 1.2 bar bench ranges with a required supply pressure of 1.4 bar can be used without positioners. In all other cases, a positioner is required.

The actuator sizing of versions with bellows seal and $p_2 \neq 0$ bar must be checked separately.

Ordering text

Globe valve	Type 3241
Nominal size	DN ...
Nominal pressure	PN ...
Body material	According to Table 1
Type of end connections	Flanges or welding ends
Characteristic	Equal percentage or linear
Pneumatic actuator	Type 3271 or Type 3277
Actuator area	240, 350 or 700 cm ²
Bench range	... bar
Solenoid valve	According to Table 1
Accessories	Positioner and/or limit switch

Specifications subject to change without notice



SAMSON AG · MESS- UND REGELTECHNIK
Weismüllerstraße 3 · 60314 Frankfurt am Main, Germany
Phone: +49 69 4009-0 · Fax: +49 69 4009-1507
samson@samson.de · www.samson.de

T 8016 EN

2017-12-18 · English