

Series 250

Type 3256-1 and Type 3256-7 Pneumatic Control Valves

Type 3256 Angle Valve

DIN version



Application

Control valve for process engineering applications with high industrial requirements

Nominal size	DN 15 to 500
Nominal pressure	PN 16 to 400
Temperatures	-196 to +550 °C



Type 3256 Angle Valve with

- Type 3271 Pneumatic Actuator (Type 3256-1 Control Valve)
- Type 3277 Pneumatic Actuator (Type 3256-7 Control Valve) for integral positioner attachment

Valve body made of

- Cast steel
- Cast stainless steel, high-temperature cast steel or cast cold-resisting steel
- Special materials

Low-noise valve plug

- Metal seal
- Soft seal up to PN 40
- High-performance metal seal
- Balanced to handle high differential pressures

The control valves, designed according to the modular assembly principle, can be equipped with various accessories: Positioners, limit switches, solenoid valves, and other accessories according to IEC 60534-6 and NAMUR recommendation. Details in Information Sheet ▶ T 8350.

Versions

Standard version with PTFE packing for temperatures from -10 to +220 °C or with adjustable high-temperature packing for -10 to +350 °C, nominal size DN 15 to 500, nominal pressure PN 16 to 400 (see Table 1)

- **Type 3256-1** (Fig. 1) · Type 3256 Valve and Type 3271 Actuator with 350 to 2800 cm² actuator area (see Data Sheets ▶ T 8310-1, ▶ T 8310-2 and ▶ T 8310-3)
- **Type 3256-7** · Type 3256 Valve and Type 3277 Pneumatic Actuator with 350 to 750v2 cm² actuator area, for integral positioner attachment (see Data Sheet ▶ T 8310-1)

Further versions

- **Welding ends or welding-neck ends** according to DIN EN 12627
- **Flow divider or AC-1/AC-2/AC-3 Trim** for noise reduction (see Data Sheets ▶ T 8081, ▶ T 8082 and ▶ T 8083)



Fig. 1: Type 3256-1 Control Valve with Type 3271 Pneumatic Actuator, positioner and solenoid valve

- **Valve plug with pressure balancing** · See Table 3
- **Perforated plug** · See Data Sheet ▶ T 8086
- **Ceramic or carbide trim** · See Data Sheet ▶ T 8071
- **Special version for flashing service**
- **Insulating section or bellows seal** · See Technical data
- **Heating jacket** · Details on request
- **Additional handwheel** · See Data Sheet ▶ T 8310-1
- **ANSI version** · NPS ½ to 20, Class 150 to 2500, see Data Sheet ▶ T 8066

- Type 3256 Valve with Type 3273 Hand-operated Actuator · For valves with max. 30 mm rated travel and side-mounted handwheel for travel > 30 mm · See Data Sheet ▶ T 8312
- Type 3256-2 Electric Control Valve · Details on request

Principle of operation

The medium flows through the valve in the direction indicated by the arrow. The valve plug determines the cross-sectional area of flow. The version with bellows seal (Fig. 3) is fitted with a test connection to monitor the stainless steel bellows.

The valves can be equipped with a flow divider (▶ T 8081) for noise reduction.

Pressure balancing must be used when high pressures or differential pressures act on the plug (Fig. 4).

Fail-safe position

Depending on how the springs are arranged in the pneumatic actuator (see Data Sheets ▶ T 8310-1, ▶ T 8310-2 and ▶ T 8310-3), the valve has two different fail-safe positions effective upon air supply failure.

- **Actuator stem extends (fail-close)**
The valve closes when the supply air fails.
- **Actuator stem retracts (fail-open)**
The valve opens when the supply air fails.

Differential pressures

The permissible differential pressures can be found in the Information Sheet ▶ T 8000-4.

Note: Fig. 2 to Fig. 5 show configuration examples.

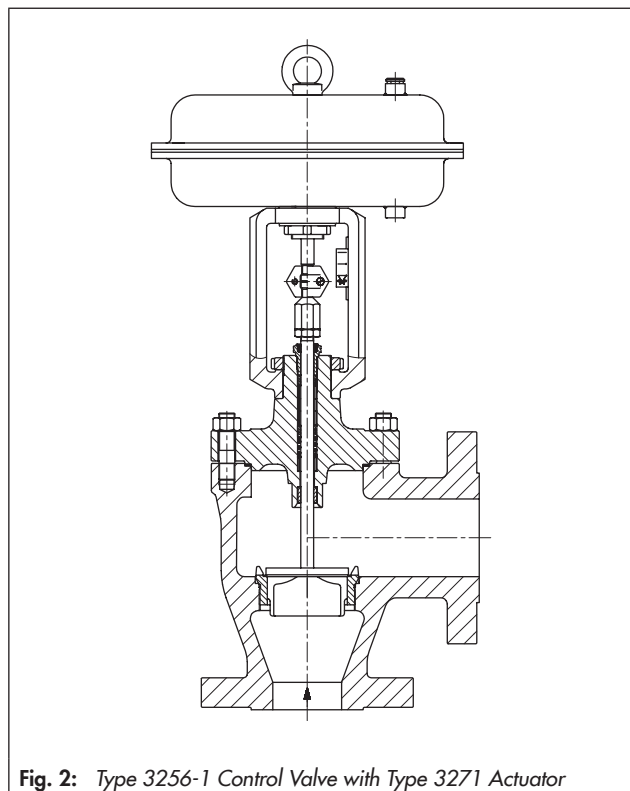

Fig. 2: Type 3256-1 Control Valve with Type 3271 Actuator

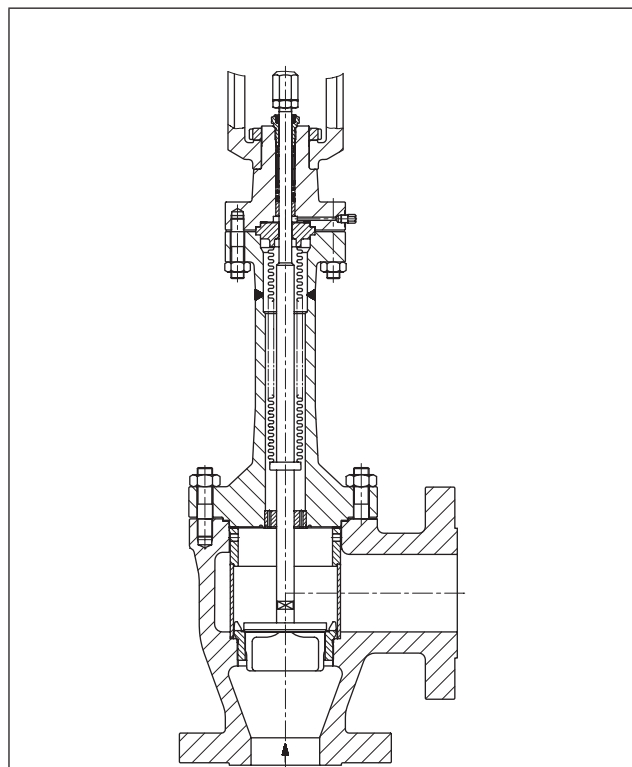

Fig. 3: Type 3256 Valve with bellows seal and flow divider ST 1

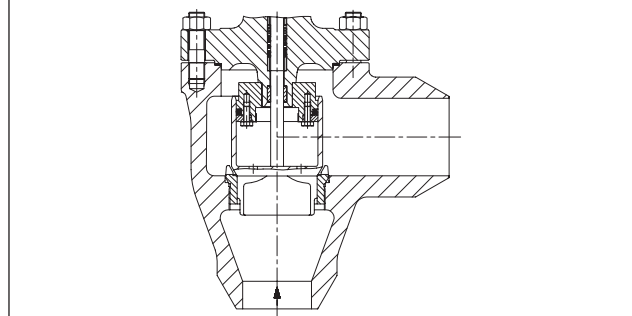

Fig. 4: Type 3256 Valve with balanced plug

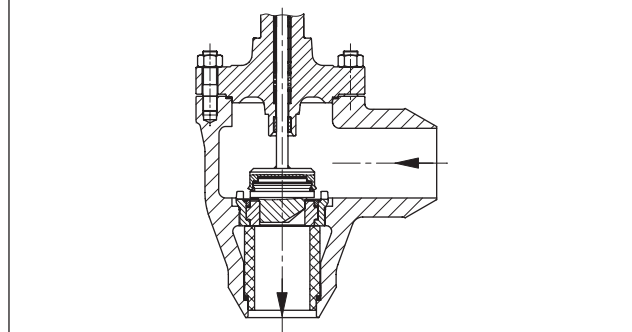

Fig. 5: Type 3256 Valve with ceramic trim and ceramic anti-wear pipe

Table 1: Technical data for Type 3256

Material		Cast steel 1.0619		Cast steel 1.7357		Cast stainless steel 1.4408	
Nominal size ¹⁾	DN	15 to 150	200 to 300	15 to 150	200 to 300	15 to 150	200 to 300
Nominal pressure ¹⁾	PN	16 to 400	16 to 100	16 to 400	16 to 100	16 to 400	16 to 100
Type of connection	Flanges	All DIN EN versions					
	Welding ends	DIN EN 12627					
Seat-plug seal		Metal seal · Soft seal · High-performance metal seal					
Characteristic		Equal percentage · Linear · Quick opening (▶ T 8000-3)					
Rangeability		50:1					
Compliance		CE · EAC					
Temperature ranges in °C · Permissible operating pressures acc. to pressure-temperature diagram (see Information Sheet ▶ T 8000-2)							
Body without insulating section		-10 to +220 °C · Up to +350 °C with high-temperature packing					
Body with	Insulating section or bellows seal	-10 to +400		-10 to +500		-196 to +550	
Valve plug ²⁾	Standard	Metal seal		-196 to +550			
		Soft seal		-196 to +220			
	Balanced with PTFE ring		-50 to +220 ³⁾				
	Balanced with graphite ring		200 to 550				
Leakage class according to IEC 60534-4							
Valve plug	Standard	Metal seal		Standard: IV · High-performance metal seal: V			
		Soft seal		VI			
	Balanced, metal seal		With PTFE ring (standard): IV · High-performance metal seal: V				
		With graphite ring: IV					

¹⁾ DN 400 and 500 on request; up to PN 400 on request

²⁾ Only in combination with suitable body material

³⁾ Lower temperatures on request

Table 2: Materials (EN material number)

Standard version Body ¹⁾		Cast steel 1.0619	Cast steel 1.7357	Cast stainless steel 1.4408
Valve bonnet		1.0460/1.0619	1.7335/1.7357	1.4408/1.4401
Seat/plug ²⁾	Metal seal	1.4006/1.4008		1.4404/1.4409
Seal ring for	Soft seal	PTFE with 15 % glass fiber		
	Pressure balancing	PTFE with carbon · Graphite		
Guide bushings		1.4112		2.4610
Packing ³⁾		V-ring packing: PTFE with carbon; spring: 1.4310 · High-temperature packing		
Body gasket		Graphite seal on metal core		
Insulating section		1.0460/1.0619	1.7335/1.7357	1.4408/1.4401
Metal bellows seal				
Intermediate piece		1.0460/1.0619	1.7335/1.7357	1.4408/1.4401
Metal bellows		1.4571 ⁴⁾		
Heating jacket		1.4404		

¹⁾ Other materials (e.g. for high-temperatures or low temperatures) as well as special materials for applications with sea water: 1.4538, duplex 1.4470, nickel-based alloy 9.4610, see pressure-temperature diagrams in Information Sheet ▶ T 8000-2

²⁾ Seats and metal-seated plug also with Stellite[®] facing or plug made of solid Stellite[®] available (up to max. K_{V5} 630)

³⁾ Other packings on request (▶ T 8000-1)

⁴⁾ Other bellows material on request

Table 3: Available K_{VS} coefficients · Versions highlighted in gray also available with balanced plug

Terms for control valve sizing according to IEC 60534, Parts 2-1 and 2-2: $F_L = 0.95$, $X_T = 0.75$

Table 3.1: Overview with flow divider ST 1 (K_{VS1}), ST 2 (K_{VS2}) and ST 3 (K_{VS3})

K_{VS}	0.1 0.16 0.25 0.4	0.63	1.0	1.6	2.5	4	6.3	10	16	25	40	63	100	160	250	360	630	1000	1500	
K_{VS1}	-			1.45	2.2	3.6	5.7	9	14.5	22	36	57	90	144	225	320	560	900	1350	
K_{VS2}						3.2	5.0	8	13.0	20	32	50	80	125	200	290	500	800	1200	
K_{VS3}	-					3.0	4.8	7.5	12	20	30	47	75	120	190	270	480	750	1100	
Seat Ø	6			12		24			31	38	50	63	80	100	125	150	200	250	300	
Travel	15										30					60			120	

Table 3.2: Versions without flow divider · PN 16 to 400

K_{VS}	0.1 0.16 0.25 0.4	0.63	1.0	1.6	2.5	4	6.3	10	16	25	40	63	100	160	250	360	630	1000	1500
DN																			
15	•	•	•	•	•	•													
25	•	•	•	•	•	•	•	•											
40	•	•	•	•	•	•	•	•	•	•									
50						•	•	•	•	•	•								
80						•	•	•	•	•	•	•	•						
100										•	•	•	•	•					
150												•	•	•	•	•			
200													•	•	• ¹⁾	•	•		
250													•	•	• ¹⁾	•	•	•	•
300													•	•	• ¹⁾	•	•	•	•

¹⁾ Pressure balancing only for \geq PN 63

Table 3.3: Versions with flow divider ST 1 · PN 16 to 160 ¹⁾

K_{VS1}	-	1.45	2.2	3.6	5.7	9	14.5	22	36	57	90	144	225	320	560	900	1350	
DN																		
15			•	•	•													
25			•	•	•	•	•											
40			•	•	•	•	•	•	•									
50					•	•	•	•	•	•								
80					•	•	•	•	•	•	•	•						
100								•	•	•	•	•	•					
150										•	•	•	•	•	•			
200											•	•	• ²⁾	•	•			
250											•	•	• ²⁾	•	•	•	•	
300											•	•	• ²⁾	•	•	•	•	

¹⁾ PN 250 to 400 with flow divider ST 1 and pressure balancing on request

²⁾ Pressure balancing only for \geq PN 63

Table 3.1: Overview with flow divider ST 1 (K_{VS1}), ST 2 (K_{VS2}) or ST 3 (K_{VS3})

K_{VS}	0.1 0.16 0.25 0.4	0.63	1.0	1.6	2.5	4	6.3	10	16	25	40	63	100	160	250	360	630	1000	1500	
K_{VS1}	-			1.45	2.2	3.6	5.7	9	14.5	22	36	57	90	144	225	320	560	900	1350	
K_{VS2}						3.2	5.0	8	13.0	20	32	50	80	125	200	290	500	800	1200	
K_{VS3}	-					3.0	4.8	7.5	12	20	30	47	75	120	190	270	480	750	1100	
Seat \varnothing	6		12		24			31	38	50	63	80	100	125	150	200	250	300		
Travel	15										30			60			120			

Table 3.4: Versions with flow divider ST 2 · PN 16 to 160 ¹⁾

K_{VS2}	-					3.2	5.0	8	13	20	32	50	80	125	200	290	500	800	1200
DN																			
50						•	•	•	•	•	•								
80						•	•	•	•	•	•	•	•						
100										•	•	•	•	•					
150												•	•	•	•	•			
200													•	•	• ²⁾	•	•		
250													•	•	• ²⁾	•	•	•	
300														•	• ²⁾	•	•	•	•

¹⁾ PN 250 to 400 with flow divider ST 2 and pressure balancing on request

²⁾ Pressure balancing only for \geq PN 63

Table 3.5: Versions with flow divider ST 3 · PN 16 to 160 ¹⁾

K_{VS3}	-					3.0	4.8	7.5	12	20	30	47	75	120	190	270	480	750	-
DN																			
50						•	•	•											
80						•	•	•	•	•	•								
100										•	•	•							
150												•	•	•	•				
200													•	•	• ²⁾	•			
250													•	•	• ²⁾	•	•		
300														•	• ²⁾	•	•	•	

¹⁾ PN 250 to 400 with flow divider ST 3 and pressure balancing on request

²⁾ Pressure balancing only for \geq PN 63

Table 4: Dimensions in mm for Type 3256-1 and Type 3256-7 in standard version

Table 4.1: Type 3256 Valve

Valve	DN	15	25	40	50	80	100	150	200	250	300
Length L (flanges and welding ends)	PN 10 to 40	90	100	115	125	155	175	225	275	On request	
	PN 63 to 160	105	115	130	150	190	215	275	325		
	PN 250	115	130	150	175	225	260	350	400		
	PN 320	115	130	150	175	225	260	350	400		
	PN 400	127 ¹⁾	150 ¹⁾	189 ¹⁾	222 ¹⁾	285 ¹⁾	333 ¹⁾	454 ¹⁾	On req.		
Height H4	PN 10 to 160	134	129	129	175	160	170	210	On req.		
	PN 250 to 400	175	170	170	221	242	296	371	547		
H8 for actuator	350 cm ²	240	240	240	240	240	240	-			
	355v2 cm ²	240	240	240	240	240	240	418	-		
	700 cm ²	240	240	240	240	240	240	418	418	-	
	750v2 cm ²	240	240	240	240	240	240	418	418	418	-
	1000 cm ²	-			295	295	295	418	418	418	-
	1400-60 cm ²				295	295	295	418	418	On request	
	1400-120 cm ²				480	480	480	503	503	503 ²⁾	650
	2800 cm ²				480	480	480	503	503	503 ²⁾	650
2 x 2800 cm ²	480				480	480	503	503	503 ²⁾	650	

¹⁾ Face-to-face dimensions according to SAMSON standard

²⁾ H8 = 650 mm with 250 mm seat bore

Table 4.2: Types 3271 and 3277 Pneumatic Actuators

Actuator area	cm ²	350	355v2	700	750v2	1000	1400-60	1400-120	2800	2 x 2800	
Diaphragm ØD	mm	280	280	390	394	462	530	534	770	770	
H ¹⁾	mm	82	121	199	236	403	333	490 ^{3)/} 580 ⁴⁾	630 ^{3)/} 695 ⁴⁾	1130 ^{3)/} 1195 ⁴⁾	
H3 ²⁾	mm	110	110	190	190	610	610	650	650	650	
H5	Type 3277 mm	101	101	101	101	-	-	-	-	-	
Thread	Type 3271	M30 x 1.5				M60 x 1.5			M100 x 2		
	Type 3277	M30 x 1.5				-	-	-	-	-	
α	Type 3271	G 3/8 (3/8 NPT)	G 3/8 (3/8 NPT)	G 3/8 (3/8 NPT)	G 3/8 (3/8 NPT)	G 3/4 (3/4 NPT)	G 3/4 (3/4 NPT)	G 1 (1 NPT)	G 1 (1 NPT)	G 1 (1 NPT)	
α2	Type 3277	G 3/8	G 3/8	G 3/8	G 3/8	-	-	-	-	-	

¹⁾ Height with welded-on lifting eyelet or height of eyebolt according to DIN 580. Height of the swivel lifting hook may differ. Actuators up to 355v2 cm² without lifting eyelet

²⁾ Minimum clearance required to remove the actuator

³⁾ Height for version with welded-on lifting eyelet (material EN-JS1030)

⁴⁾ Height for version with female thread (material 1.5638/A352 LC3)

Table 5: Weights in kg for Type 3256-1 and Type 3256-7 in standard version

Table 5.1: Type 3256 Valve

Valve	DN	15	25	40	50	80	100	150	200	250	300
Valve without actuator	PN 16 to 40	12	15	22	35	58	75	190	420	On request	
	PN 63 to 160	20	25	33	58	92	125	300	On request		
	PN 250 to 400	On request									

Table 5.2: Types 3271 and 3277 Pneumatic Actuators

Actuator	cm ²	350	355v2	700	750v2	1000	1400-60	1400-120	2800	2 x 2800
Type 3271	Without handwheel	8	15	22	36	85	70	175	450	950
	With handwheel	13	20	27	41	190	175	300 ¹⁾ /425 ²⁾	575 ¹⁾ /700 ²⁾	On request
Type 3277	Without handwheel	12	19	26	40	-				
	With handwheel	17	24	31	45					

¹⁾ Side-mounted handwheel up to 80 mm travel

²⁾ Side-mounted handwheel above 80 mm travel

Table 6: Dimensions in mm and weights in kg for Type 3256 Valve with insulating section · Without actuator

Nominal size	DN	15	25	40	50	80	100	150	200	250	300
Height H4	PN 10 to 160	335	330	331	445	430	440	560	On request		
	PN 250 to 400	370	366	366	486	500	546	717			
Weight without actuator	PN 16 to 40	18	21	28	45	68	85	200	On request		
	PN 63 to 160	26	31	39	68	102	135	315			
	PN 250 to 400	On request									

Table 7: Dimensions in mm and weights in kg for Type 3256 with bellows seal · Without actuator

Valve size	DN	15	25	40	50	80	100	150	200	250	300	
	Travel											
Height H4	PN 10 to 40	15 to 120	343	338	339	566	561	541	606	904	On request	
	PN 63 to 100	120	-									
	PN 63 to 160	15 to 60	343	338	339	566	561	541	739	On req.	-	
	PN 250 to 320		621	617	610	524	500	611	On req.			
	PN 400		621	617	610	On request						
Weight without actuator	PN 16 to 40		18	21	28	45	68	85	200	On request		
	PN 63 to 160		26	31	39	68	102	135	315			
	PN 250 to 400		On request									

Dimensional drawings

Type 3271 Pneumatic Actuator

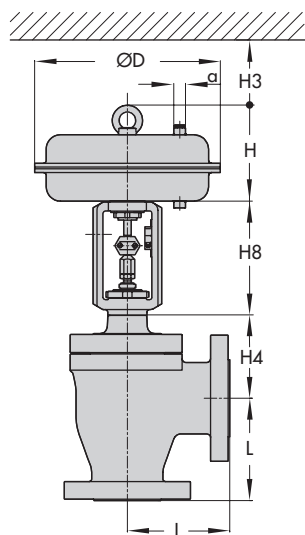

Type 3256-1

Type 3277 Pneumatic Actuator

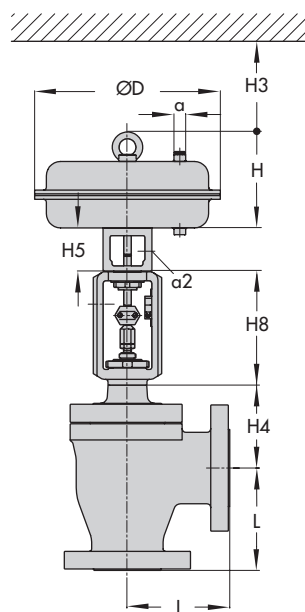

Type 3256-7

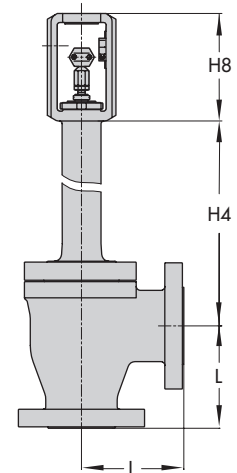

Type 3256 with bellows seal or insulating section

Type 3256 with heating jacket

Dimensions on request

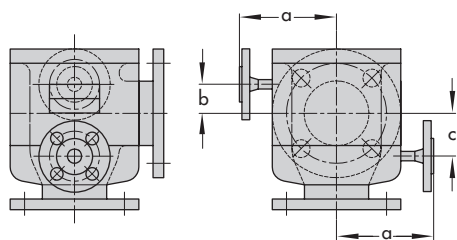

Selection and sizing of the control valve

1. Calculate K_V coefficient according to IEC 60534.
2. Select nominal size DN and K_{VS} coefficient from Table 3.
3. Select the actuator and determine the permissible differential pressure from the Information Sheet ► T 8000-4.
4. Select the valve body material from Table 1 and Table 2 as well as from the pressure-temperature diagrams (see Information Sheet ► T 8000-2).
5. Select accessories from Table 1 and Table 2.

Ordering data

Nominal size	DN
Nominal pressure	PN
Body material	According to Table 2
Bonnet	Standard bonnet, insulating section or bellows seal
Type of connection	Flanges/welding ends
Plug	Standard or balanced Soft seal, metal seal or high-performance metal seal
Characteristic	Equal percentage, linear or quick opening
Actuator	Type 3271 or Type 3277 (see Data Sheets ► T 8310-1, ► T 8310-2 and ► T 8310-3)
Fail-safe position	Fail-close or fail-open
Process medium	Density in kg/m^3 and temperature in $^{\circ}\text{C}$
Flow coefficient	kg/h or m^3/h in standard or operating state
Pressure	p_1 and p_2 in bar (absolute pressure p_{abs}), with minimum, normal and maximum flow rate
Valve accessories	Positioner and/or limit switch

Specifications subject to change without notice



SAMSON AG · MESS- UND REGELTECHNIK
 Weismüllerstraße 3 · 60314 Frankfurt am Main, Germany
 Phone: +49 69 4009-0 · Fax: +49 69 4009-1507
 samson@samson.de · www.samson.de

T 8065 EN

2017-12-20 · English